

1 EXISTING STAIR PLAN
A1.01 1/2" = 1'-0"

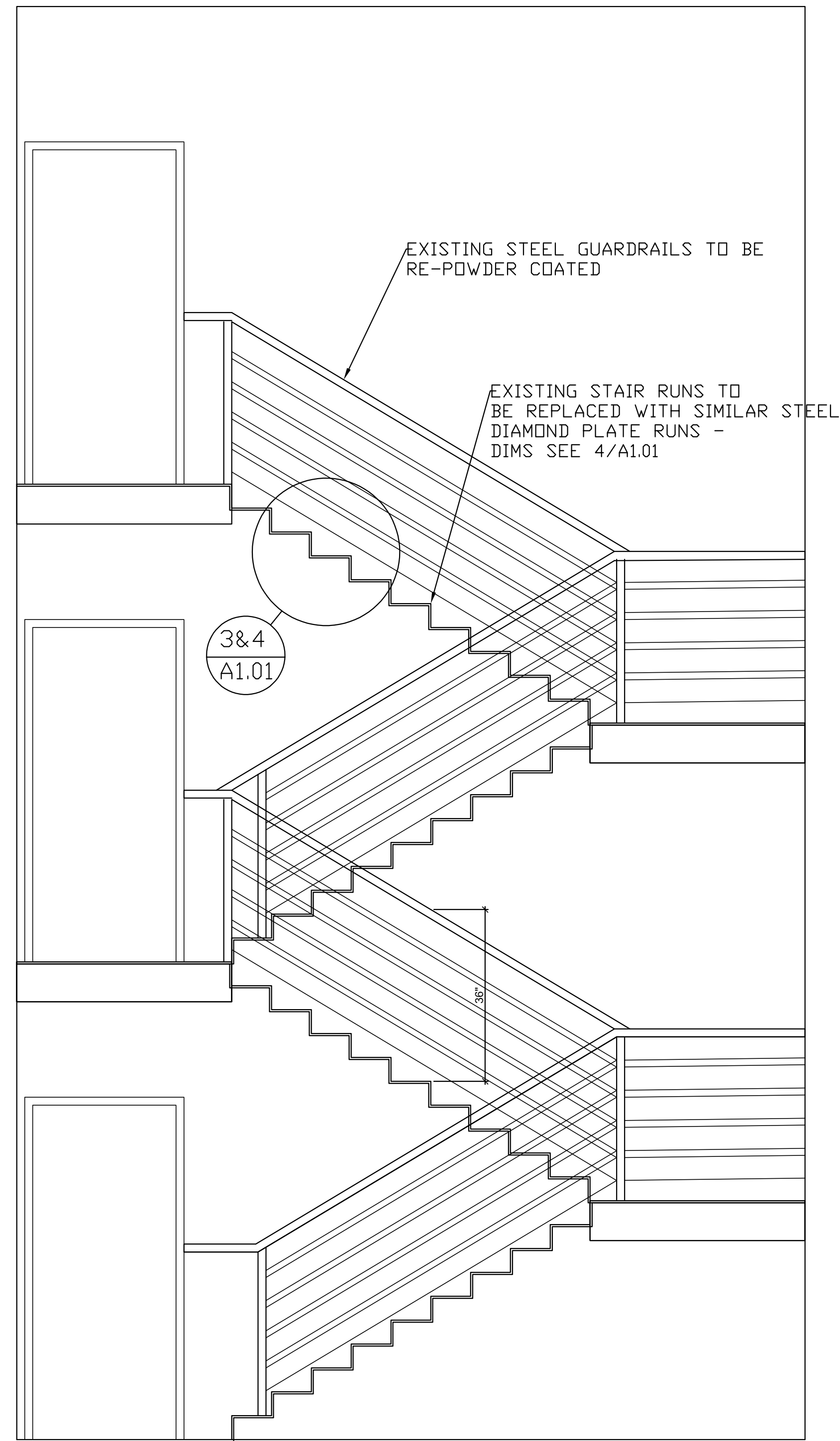

2 EXISTING STAIR SECTION A
A1.01 1/2" = 1'-0"

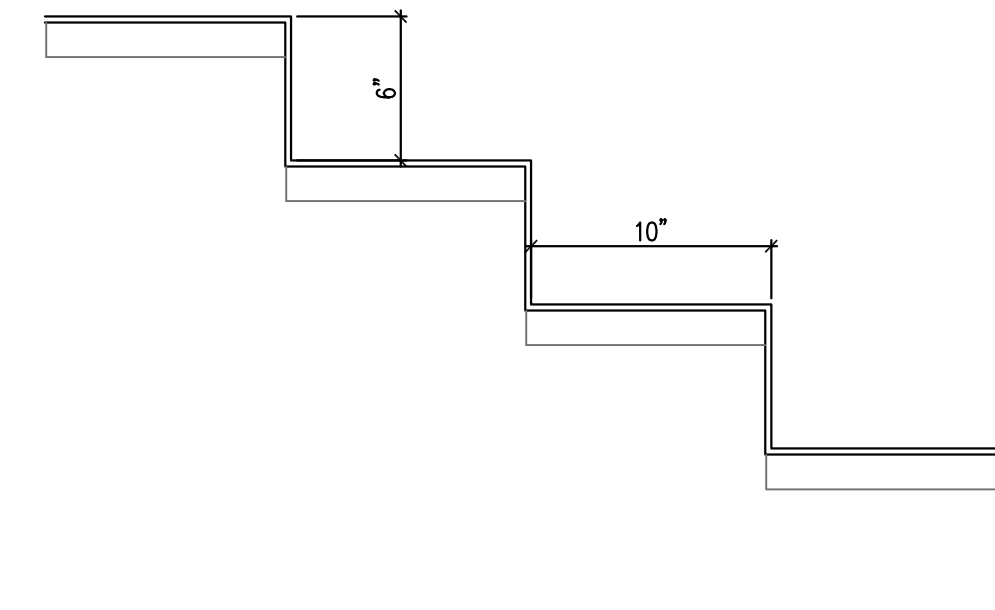

3 EXISTING RISER & RUN
A1.01 1 1/2" = 1'-0"

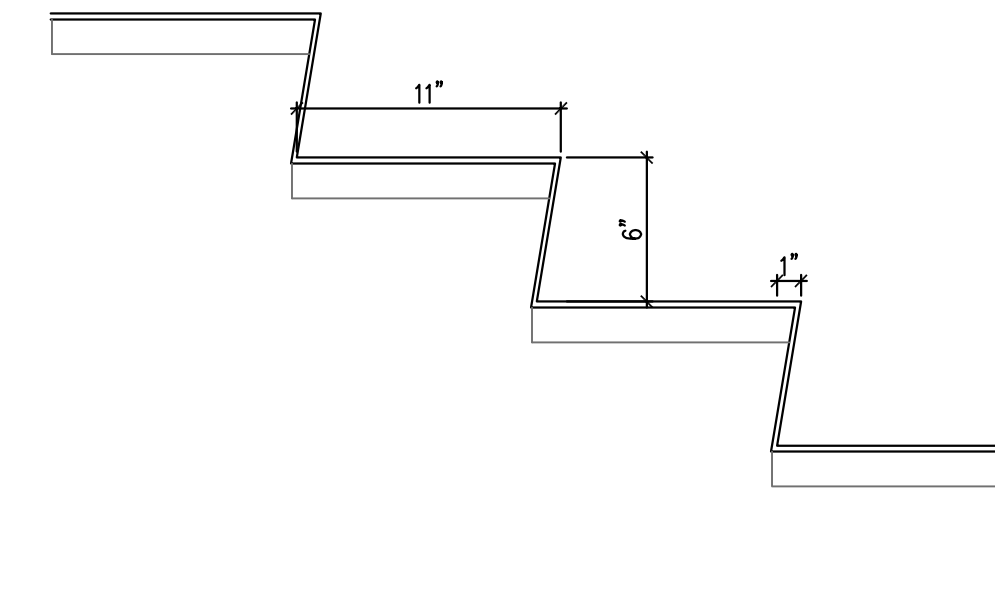

4 PROPOSED RISER & RUN
A1.01 1 1/2" = 1'-0"

IEBC 2009
EXIST GUARDRAILS TO REMAIN 605.10.1
RISE 6", RUN 11" 1009.4.2
LANDINGS >= STAIR WIDTH 1009.5

NFPA 101 2009 7.2.2.4.5.2 EX. 3
EXIST GUARDRAILS TO REMAIN (>30") 7.2.2.3.3.3
SLOPED RISERS W/ 1" PROJECTION 7.2.2.3.2.2
LANDINGS >= STAIR WIDTH

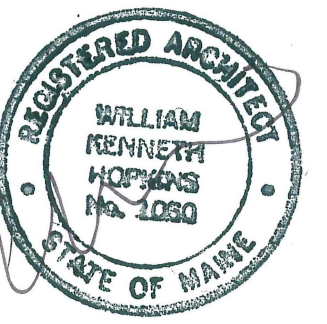

Prepared For:

Consultant:

Architect: ARCHETYPE
48 Union Wharf Portland, Maine 04101
(207) 772-6022 Fax (207) 772-4056

Project: Chestnut Street
Garage Stairwell
Chestnut Street,
Portland, ME

Revisions:

Scale: AS NOTED

Date: 4-17-2017

STAIR REPAIRS

A1.01