

COMPARTMENTALIZATION NOTES:

ALL DWELLING UNITS SHALL BE COMPARTMENTALIZED IN ORDER TO PREVENT AIR LEAKAGE BETWEEN UNITS OR BETWEEN UNITS AND ADJACENT SPACES.

SEAL BOTTOM PLATE TO STRUCTURAL SHEATHING; SEAL DRYWALL TO TOP AND BOTTOM PLATE AT DEMISING PARTITIONS; SEAL FIRST PARTITION STUD TO STRUCTURAL SHEATHING AT EXTERIOR WALL ASSEMBLIES.

SEAL ALL PENETRATIONS IN DWELLING UNIT WALLS, CEILINGS, AND FLOORS.

SEAL ALL VERTICAL CHASES ADJACENT TO UNITS.

SEE DETAIL C5/A501 FOR SEALING OF FLOOR/CEILING ASSEMBLY AT EXTERIOR WALL.

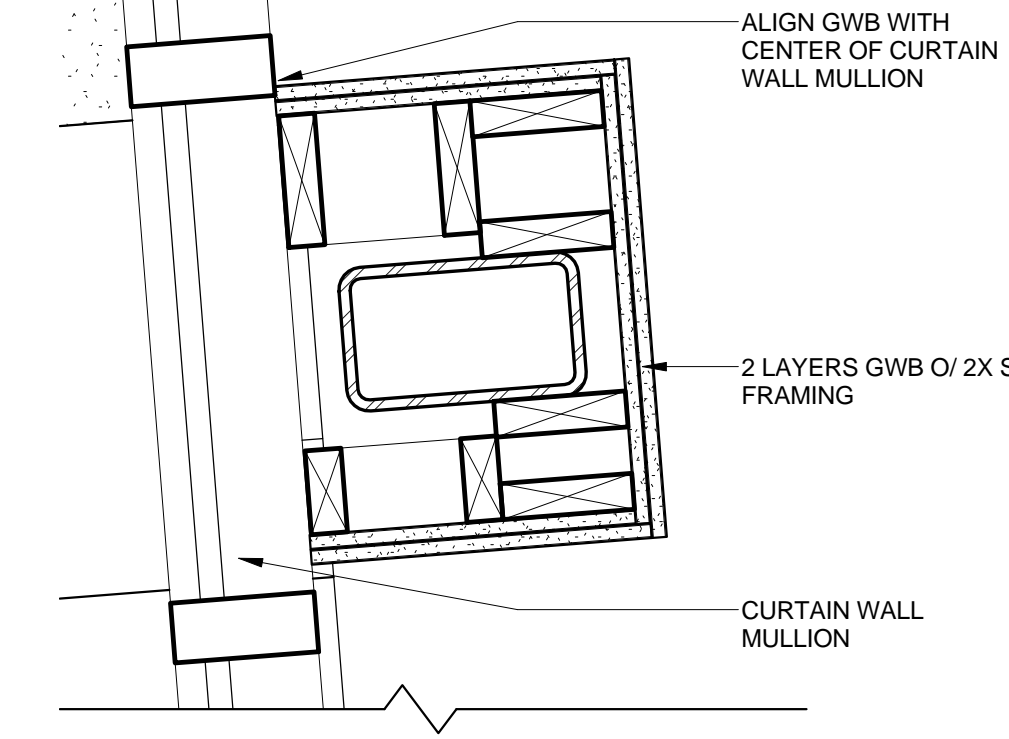

E4 TYPICAL COLUMN ENCLOSE AT LINK
1 1/2" = 1'-0"

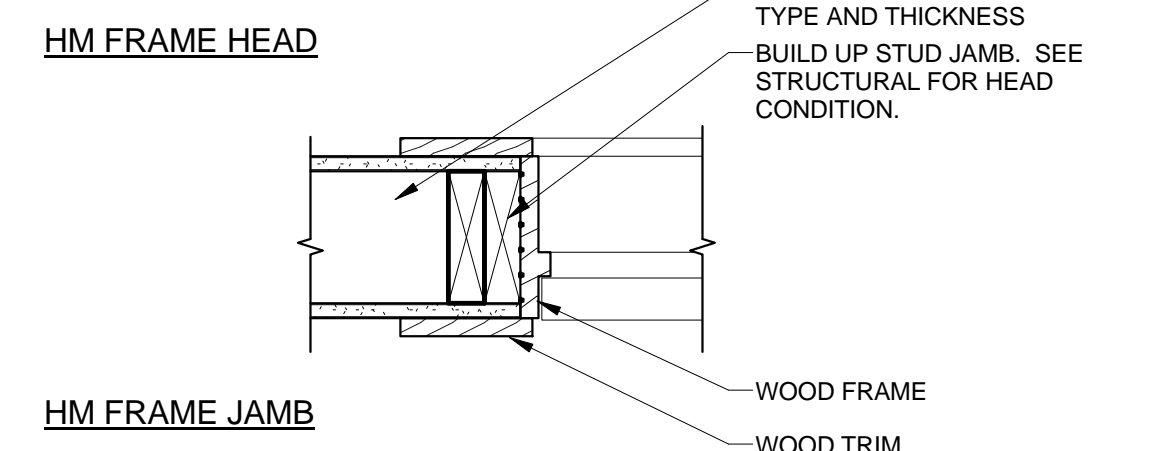
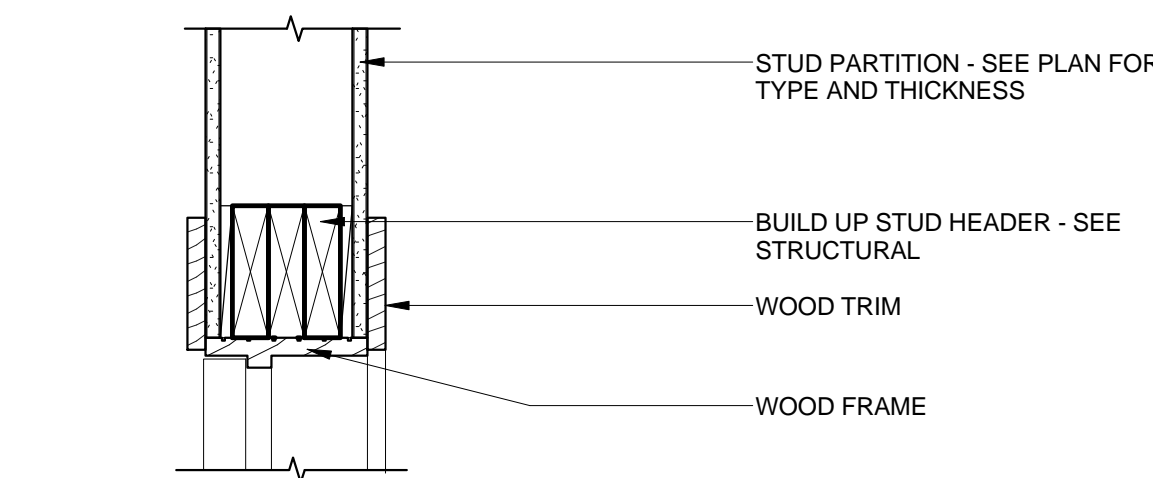

E3 WOOD FRAME DETAILS @ GWB
1 1/2" = 1'-0"

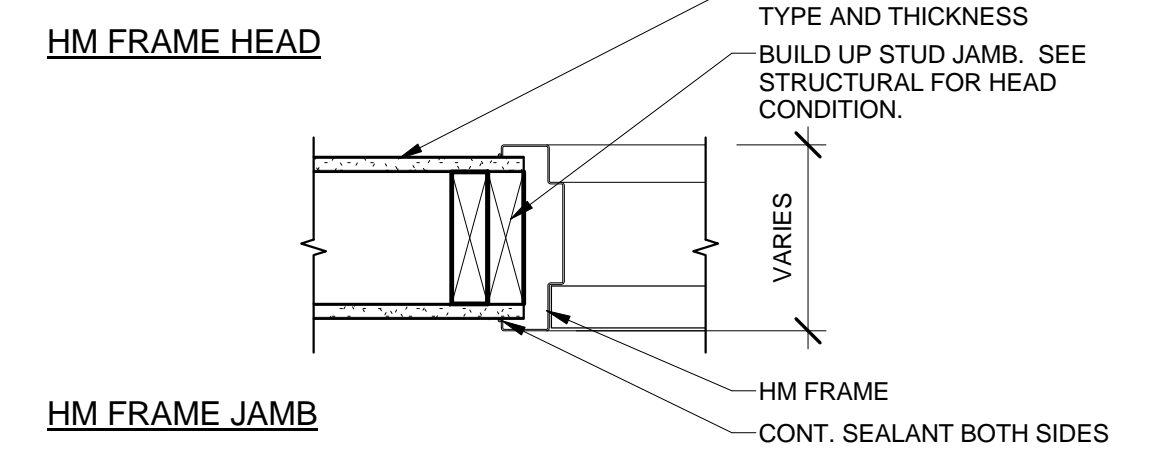
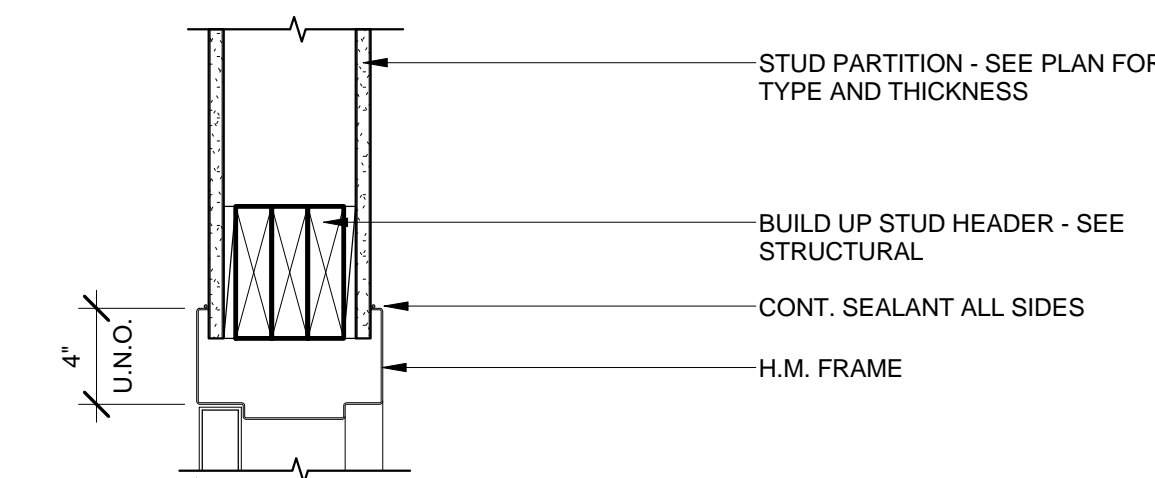

E2 HM FRAME DETAILS @ GWB
1 1/2" = 1'-0"

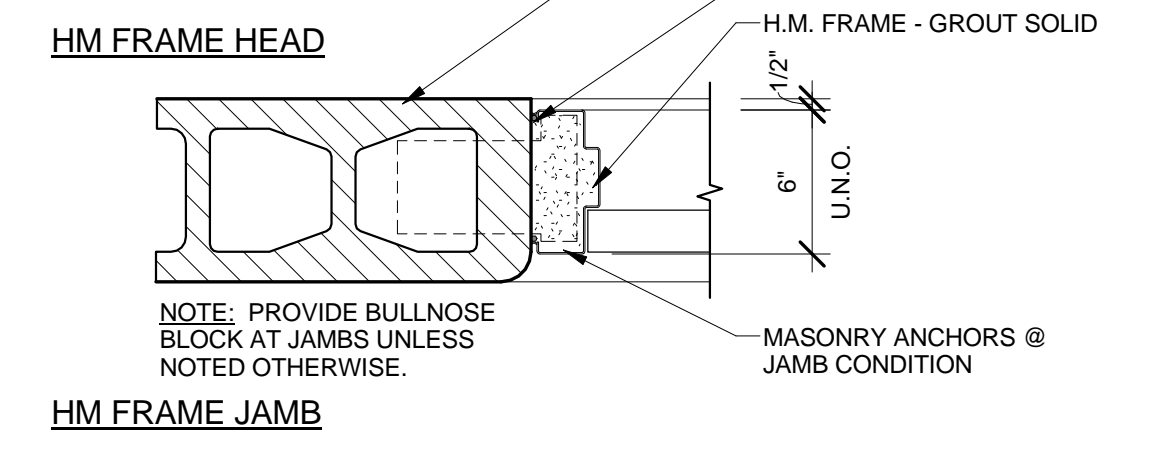
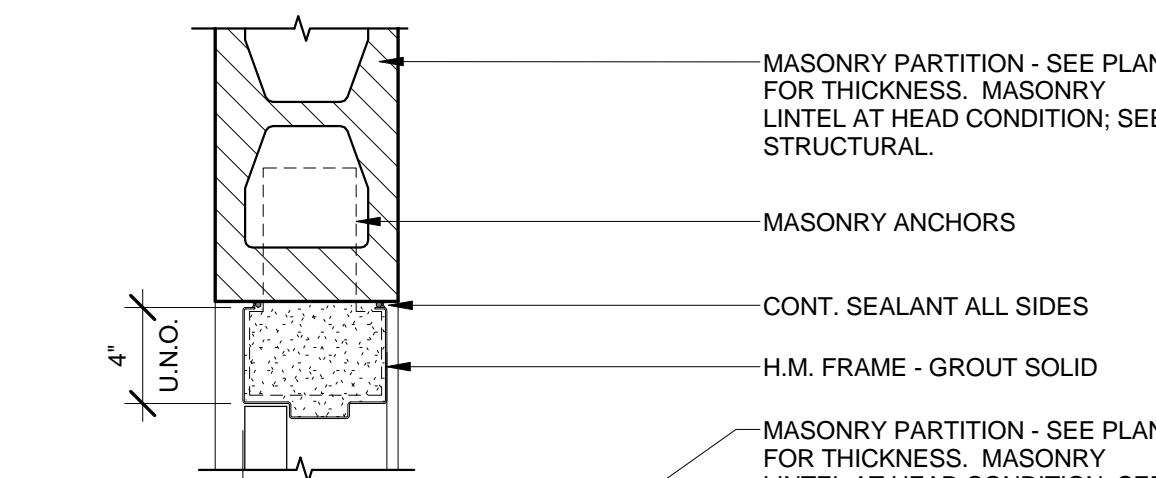

E1 HM FRAME DETAILS @ CMU
1 1/2" = 1'-0"

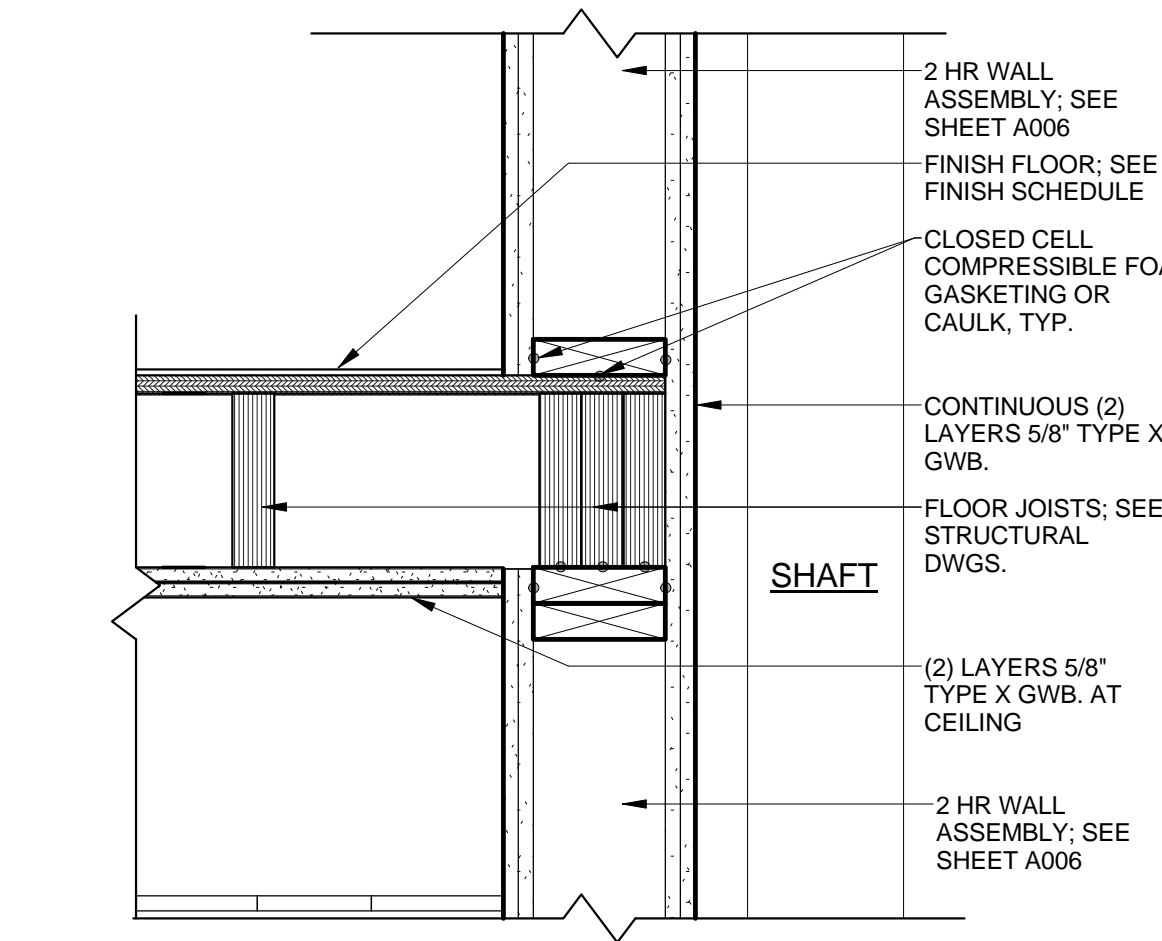

D5 RATED FLOOR AT 2HR RATED ENCLOSURE
1 1/2" = 1'-0"

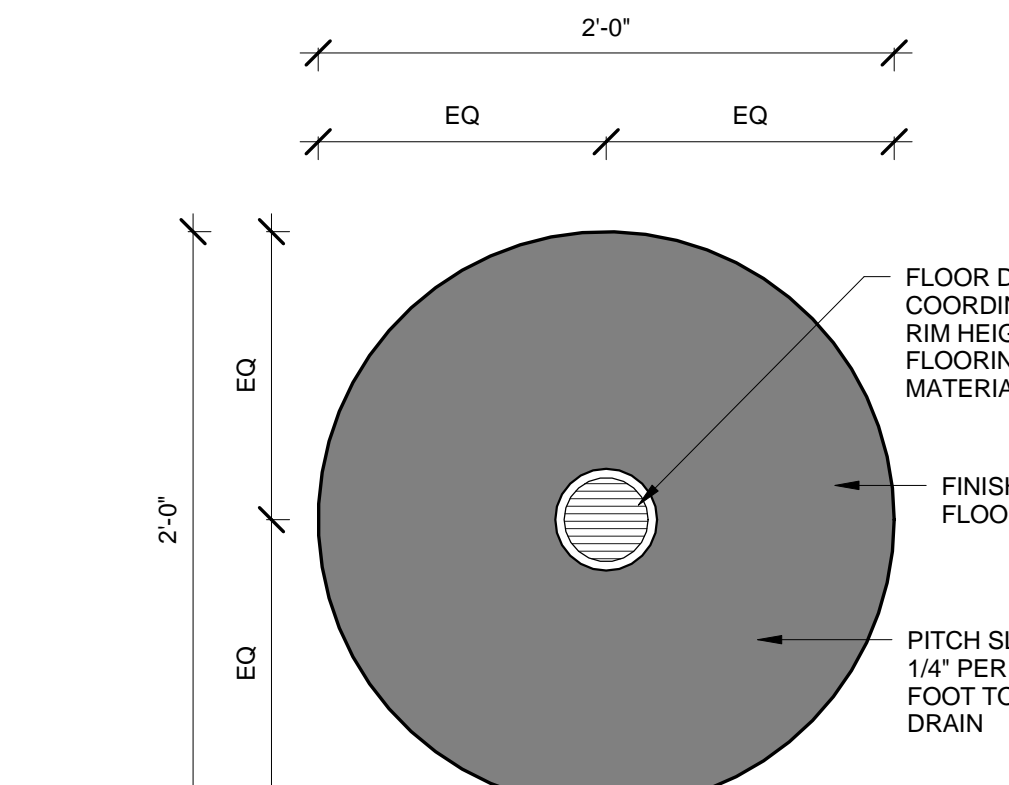

D4 FLOOR DRAIN - CIRCULAR
1 1/2" = 1'-0"

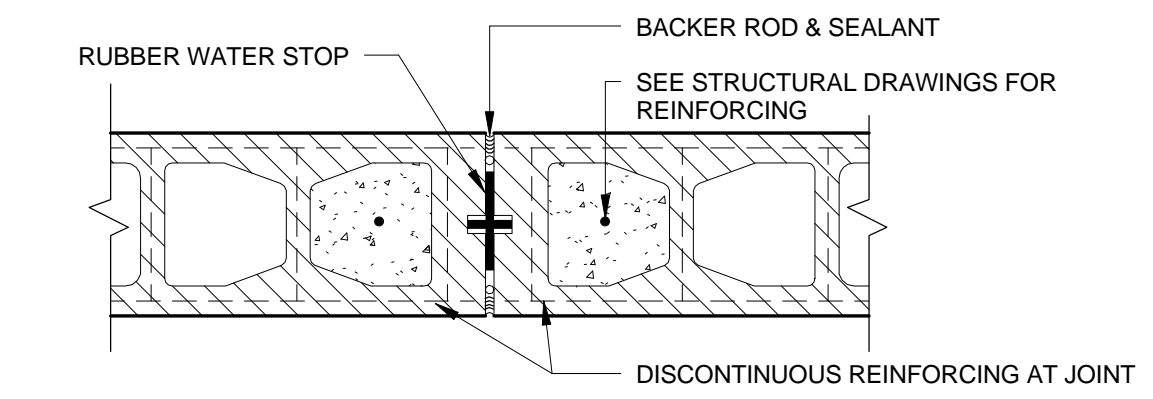

D3 CONTROL JOINT AT EXTERIOR CMU WALL
1 1/2" = 1'-0"

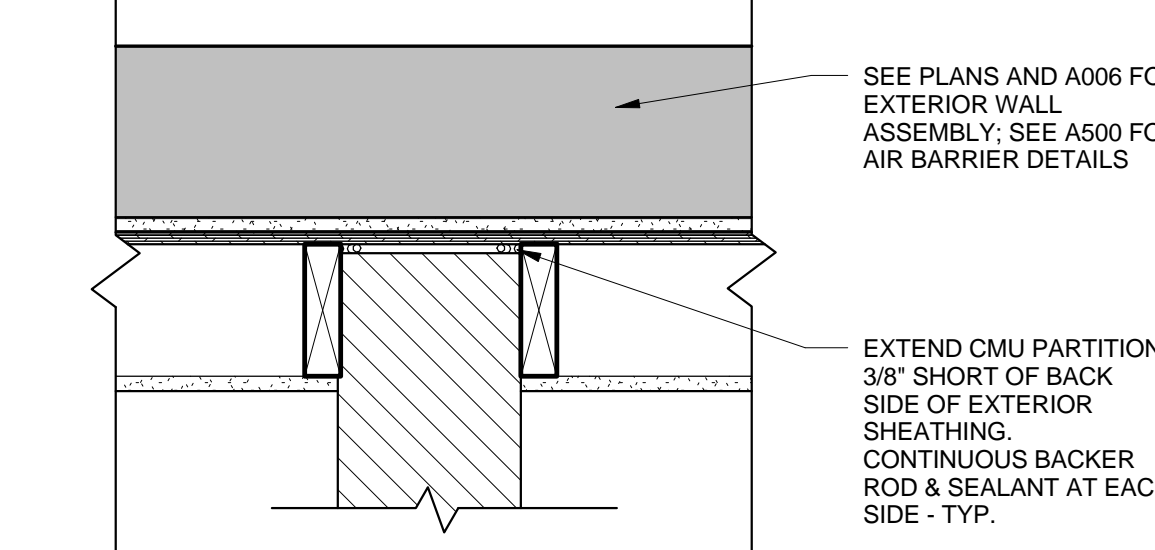

D2 TYPICAL WALL INTERSECTIONS
1 1/2" = 1'-0"

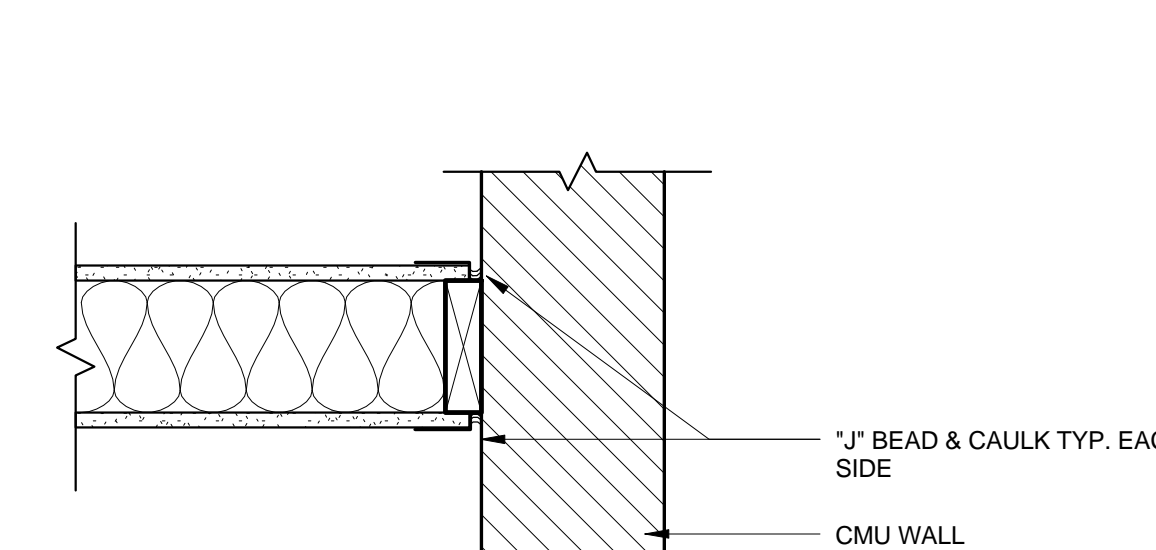

D1 PARTITION STANDARDS
1 1/2" = 1'-0"

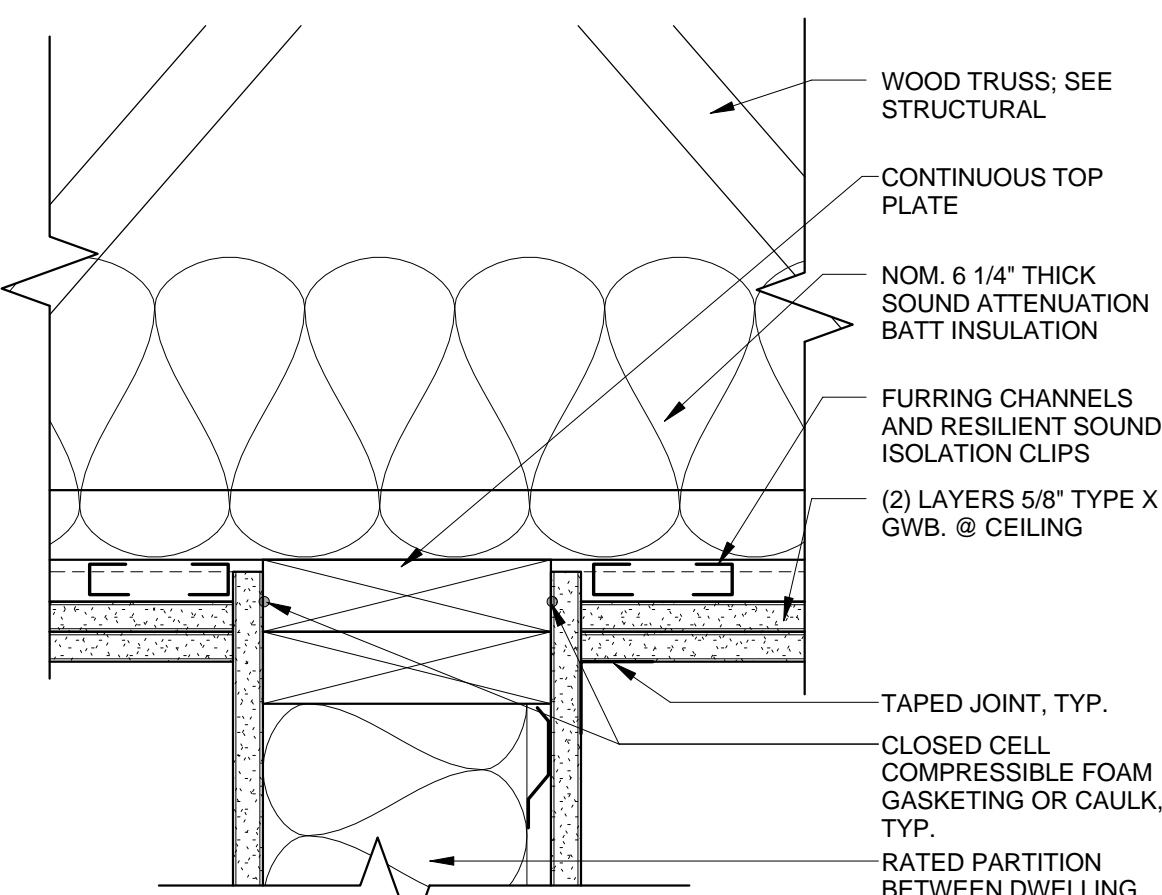

C5 COMPARTMENTALIZATION - PARTITION TO CEILING
3" = 1'-0"

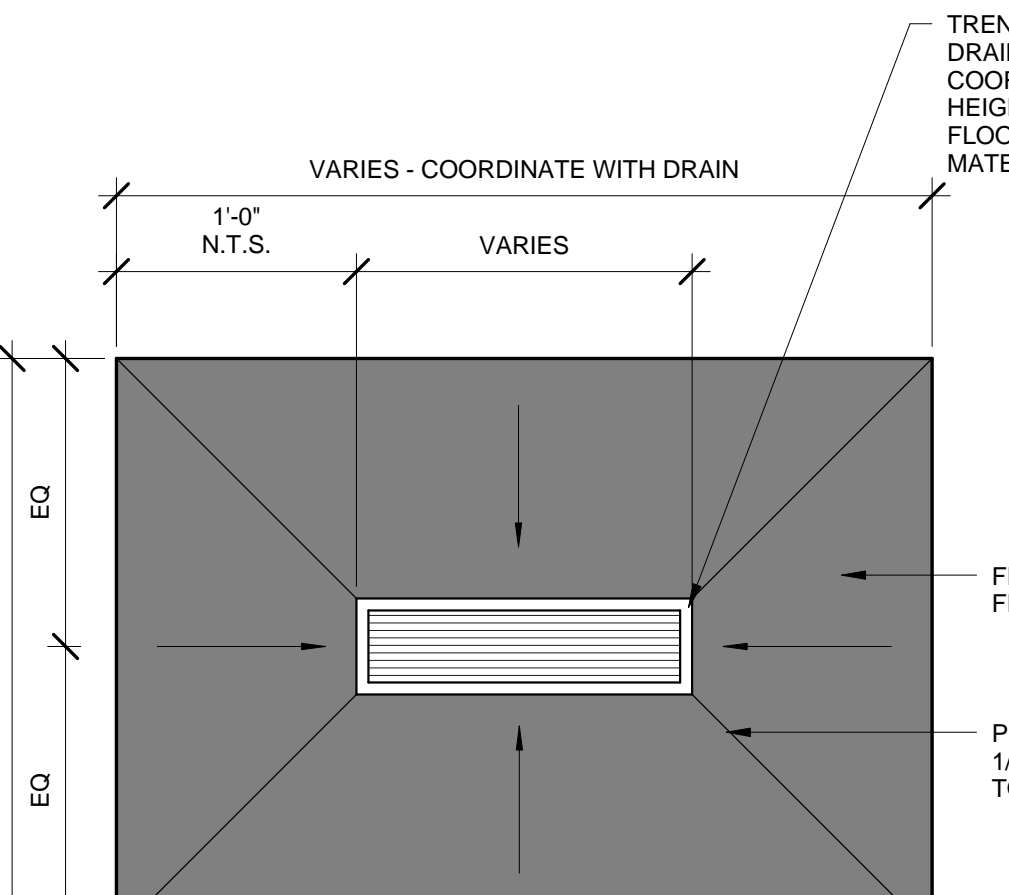

C4 FLOOR DRAIN - RECTANGULAR
1 1/2" = 1'-0"

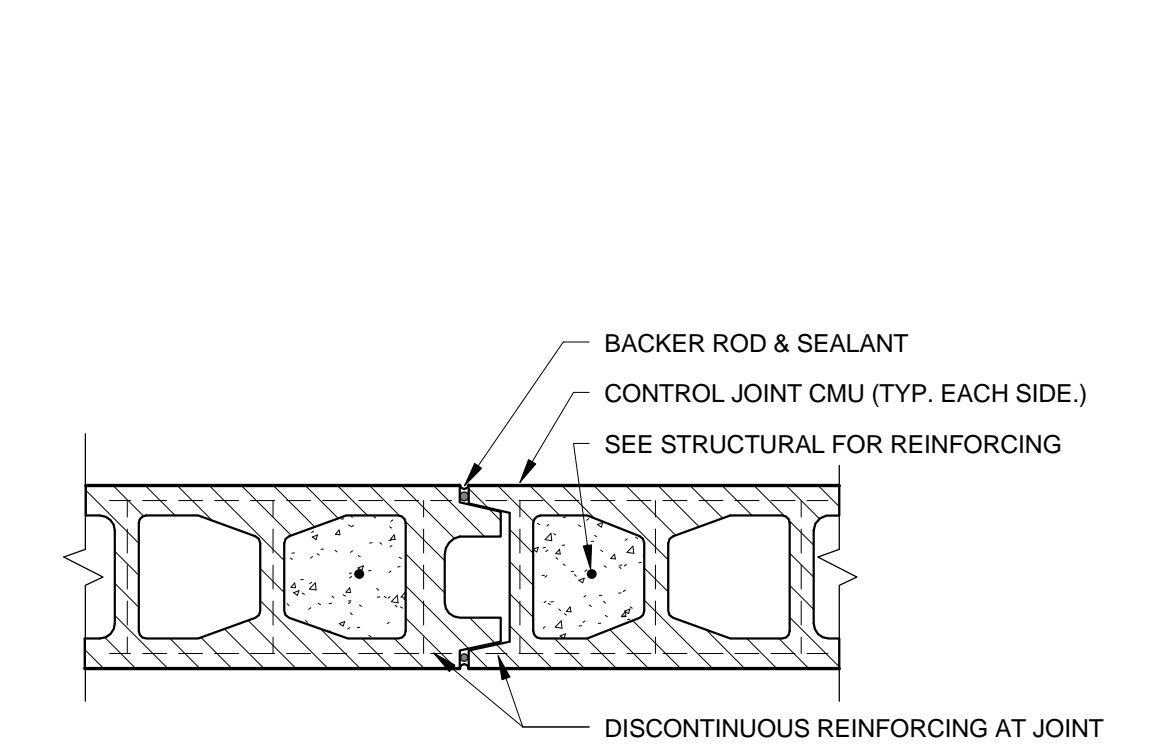

C3 CONTROL JOINT AT INTERIOR CMU PARTITION
1 1/2" = 1'-0"

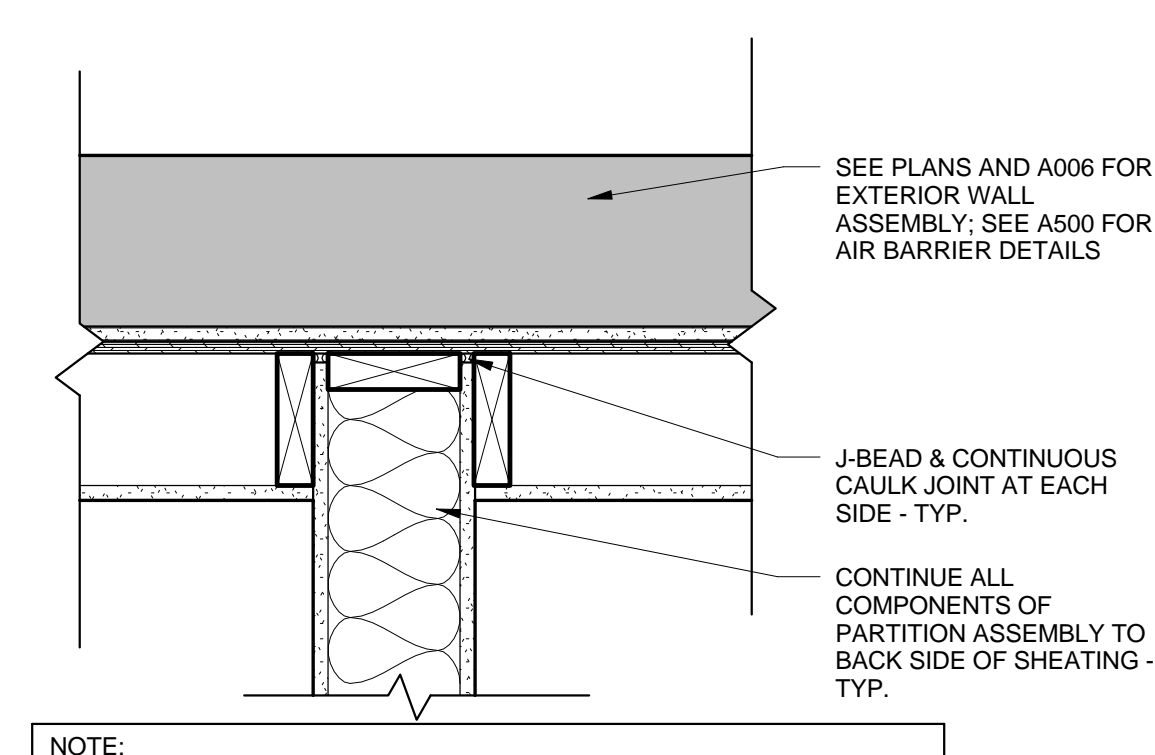

C2 TYPICAL WALL INTERSECTIONS
1 1/2" = 1'-0"

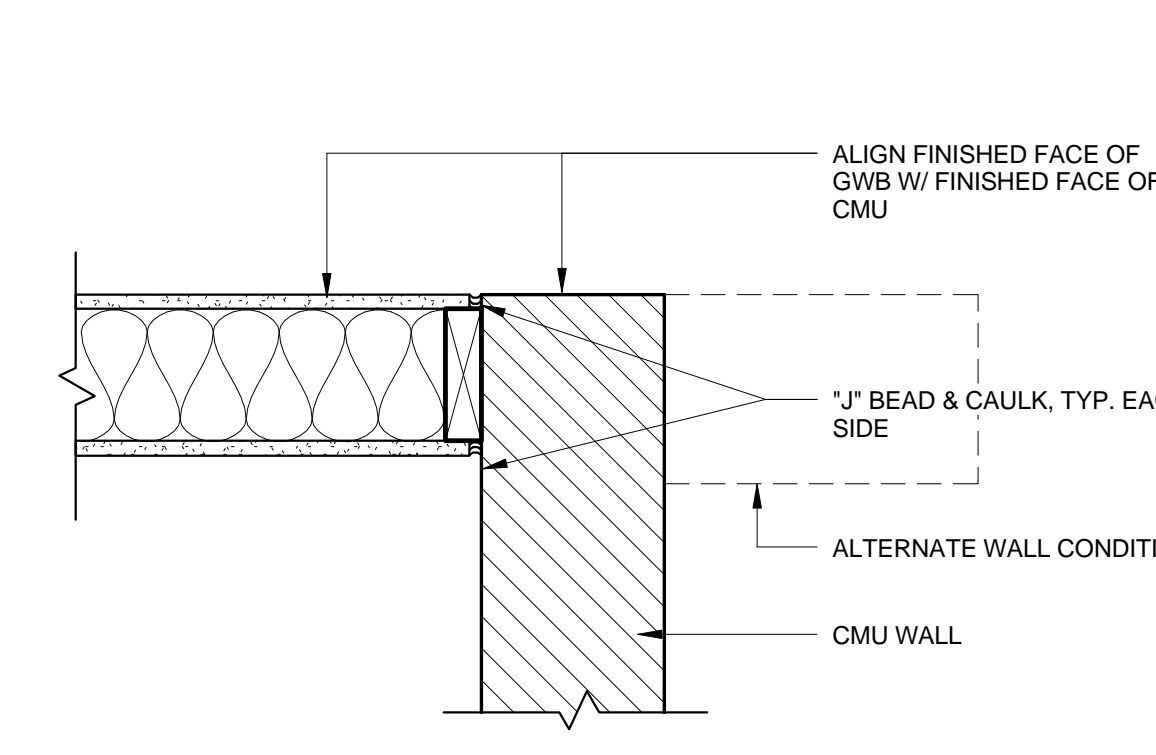

C1 PARTITION STANDARDS
1 1/2" = 1'-0"

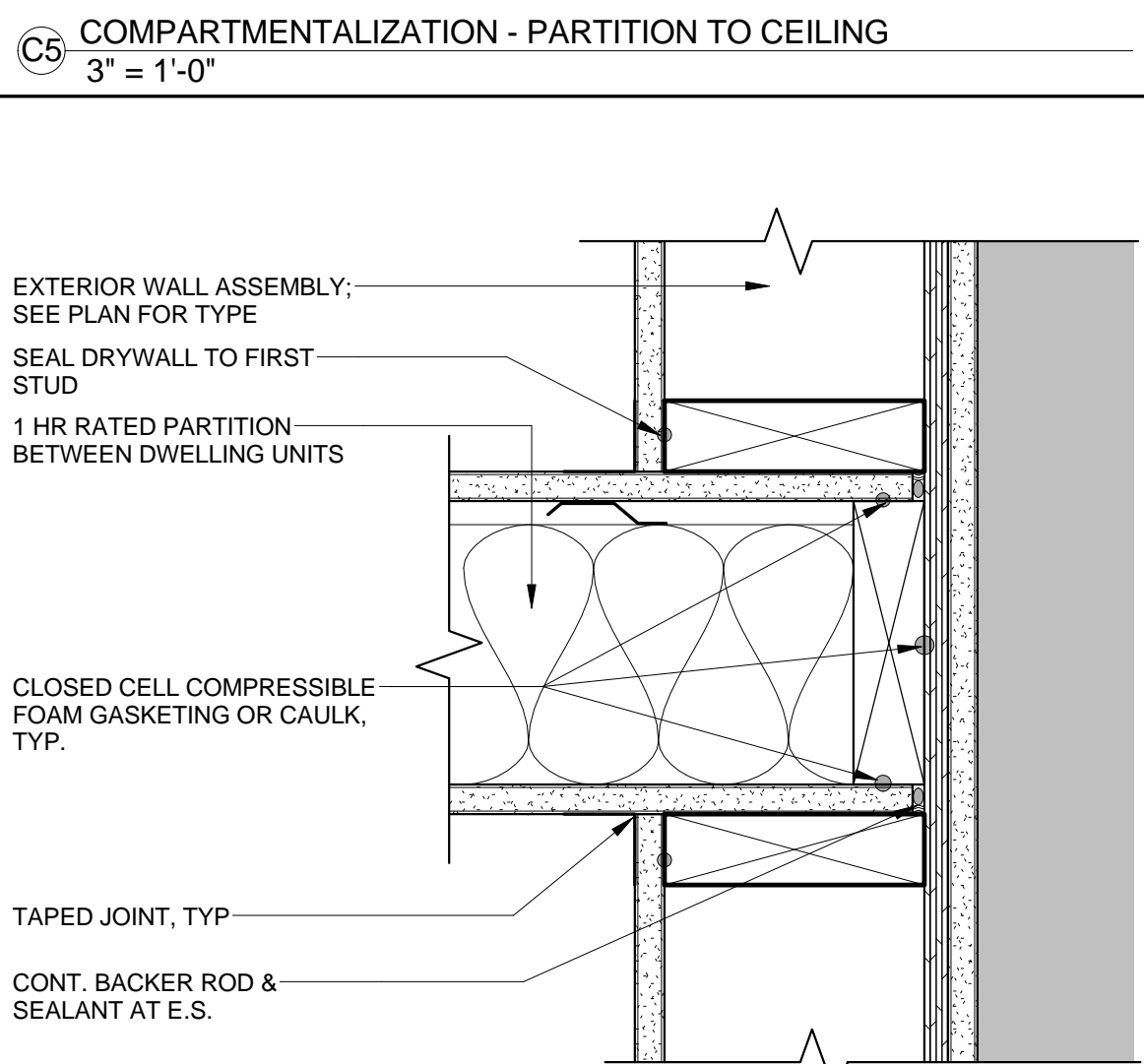

B5 COMPARTMENTALIZATION - PARTITION TO EXTERIOR WALL
3" = 1'-0"

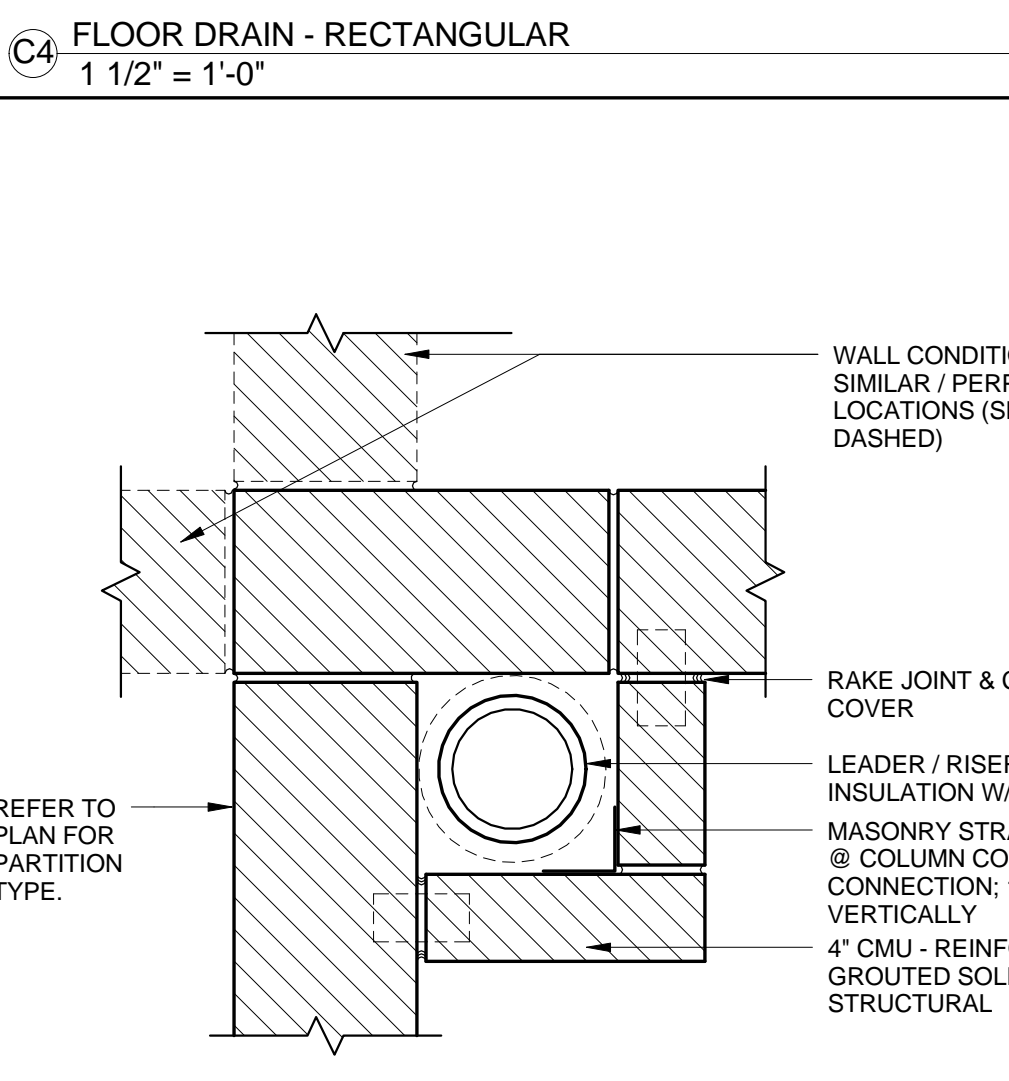

A4 LEADER / RISER ENCLOSURE
1 1/2" = 1'-0"

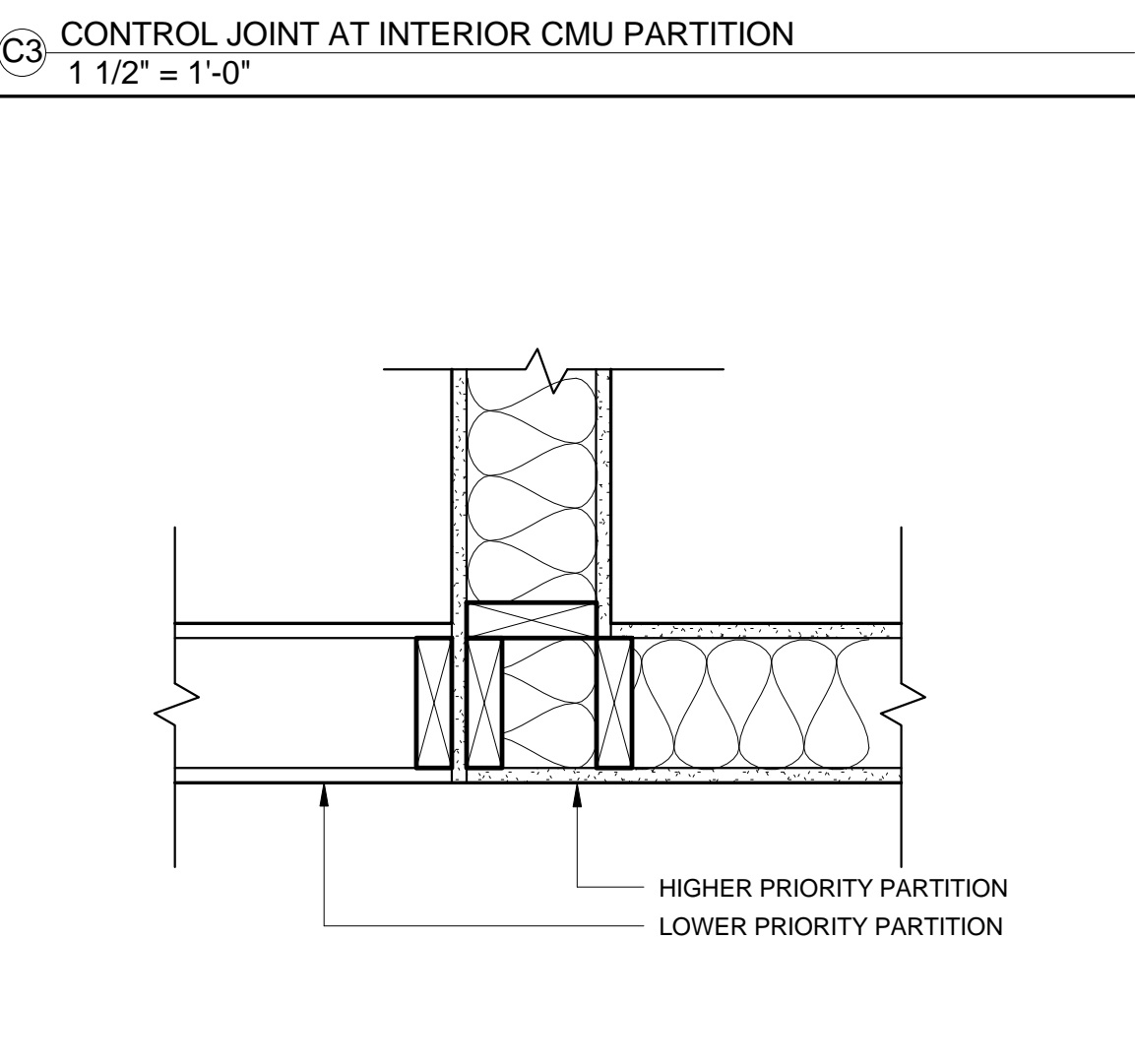

A3 PARTITION PRIORITY
1 1/2" = 1'-0"

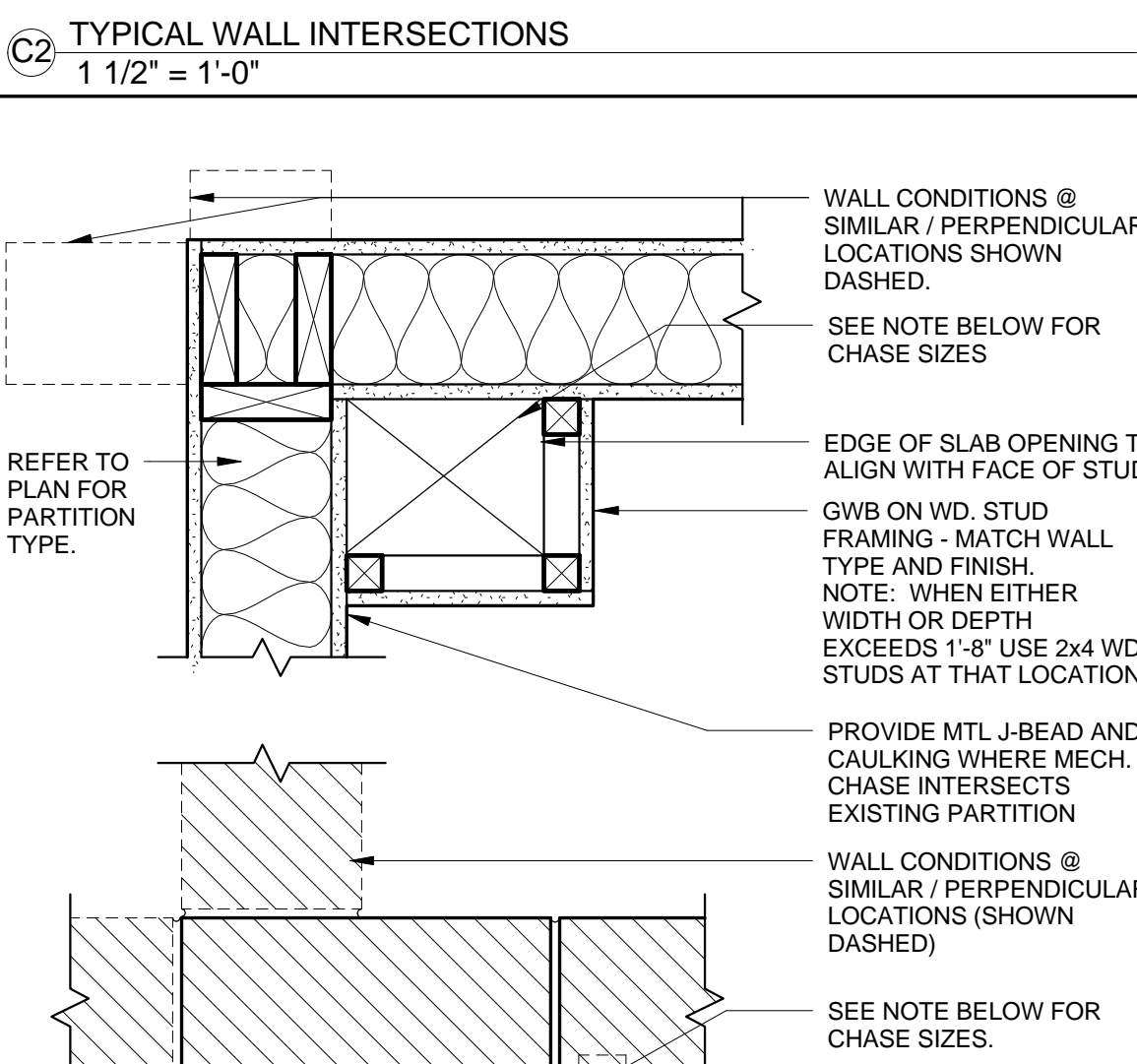

A2 CHASE AT INTERIOR PARTITION
1 1/2" = 1'-0"

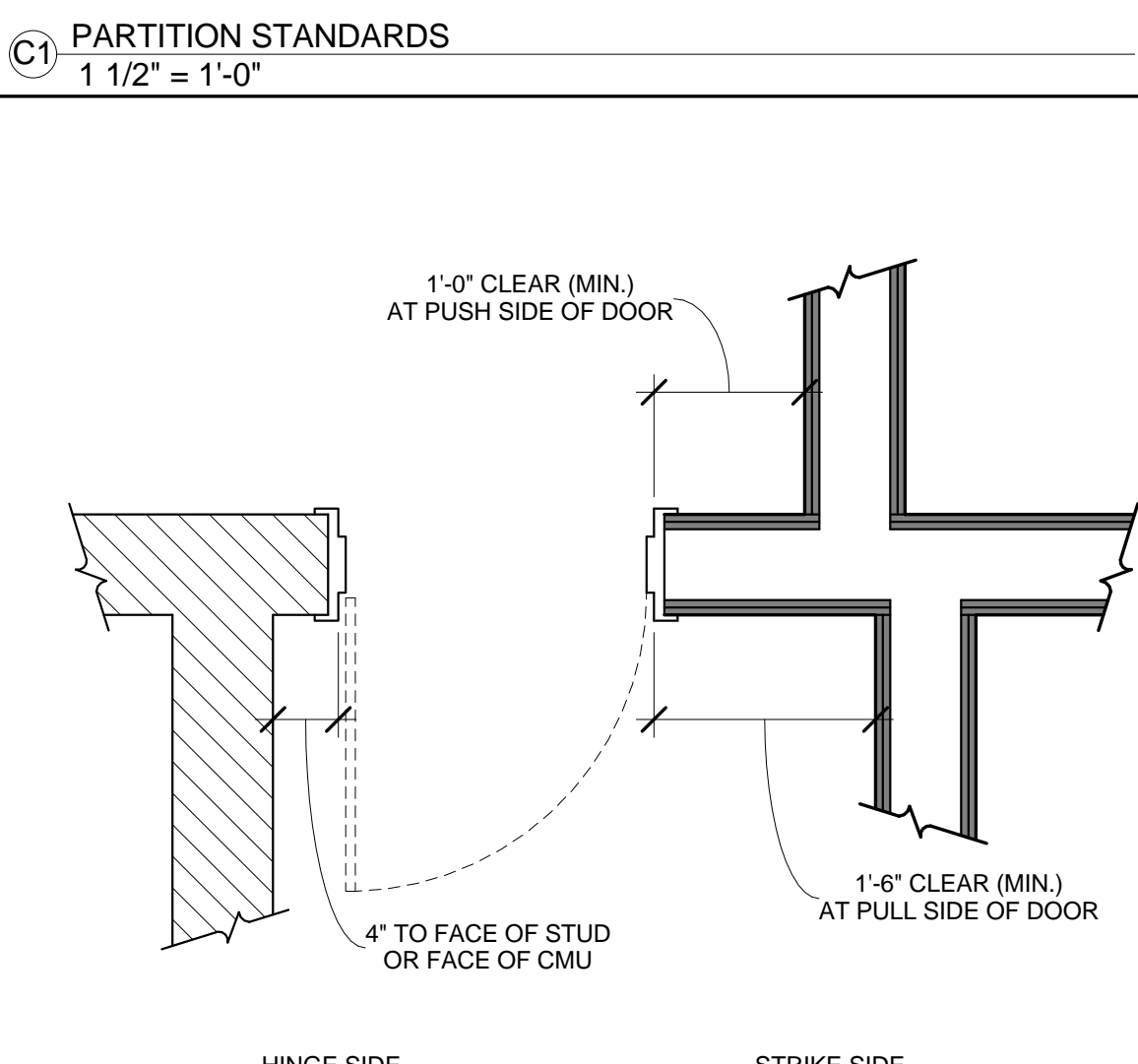

A1 DIMENSIONAL STANDARDS
1 1/2" = 1'-0"

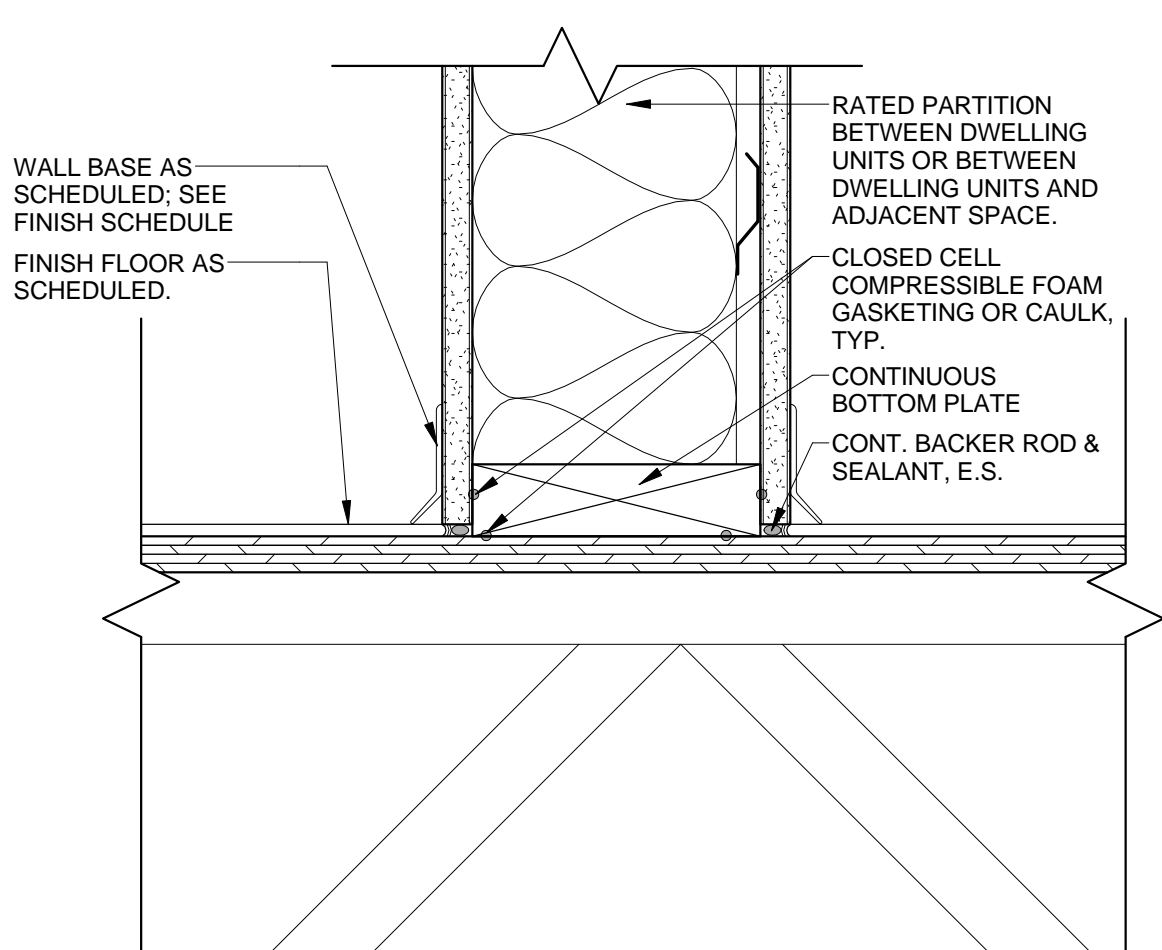

A5 COMPARTMENTALIZATION - PARTITION TO FLOOR
3" = 1'-0"

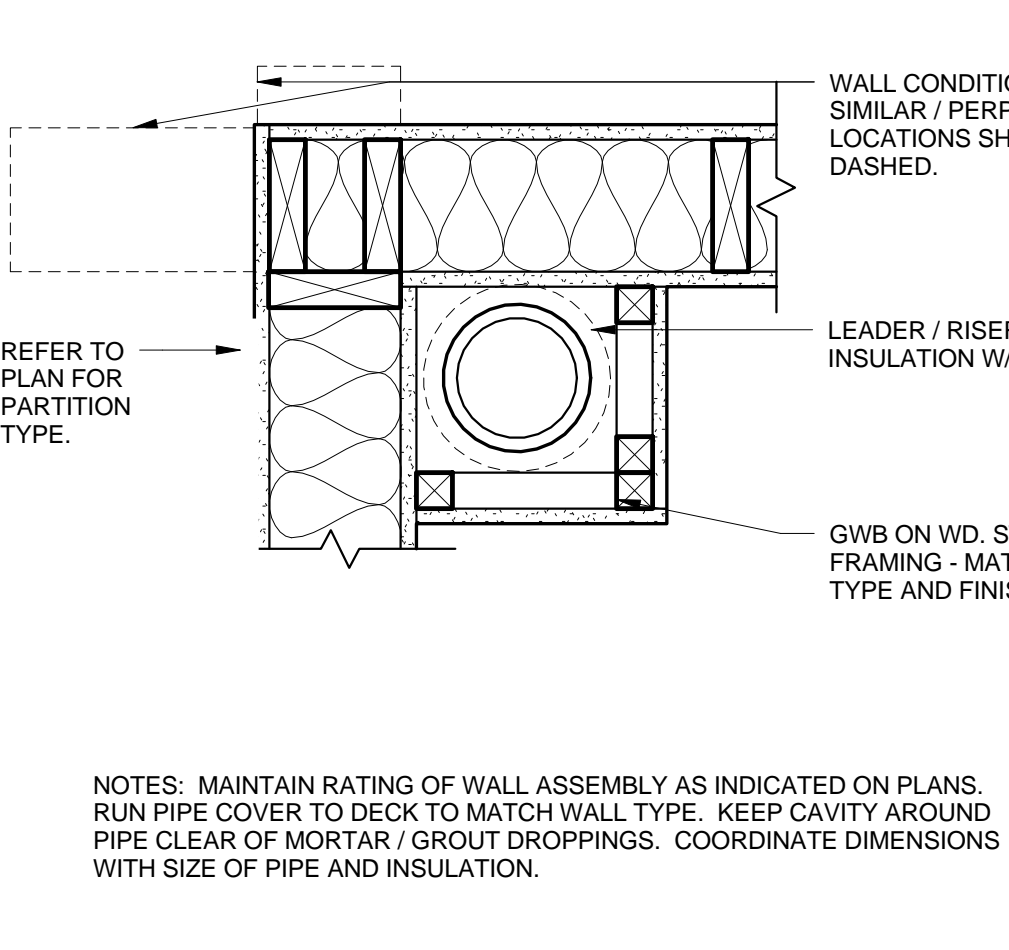

A4 LEADER / RISER ENCLOSURE
1 1/2" = 1'-0"

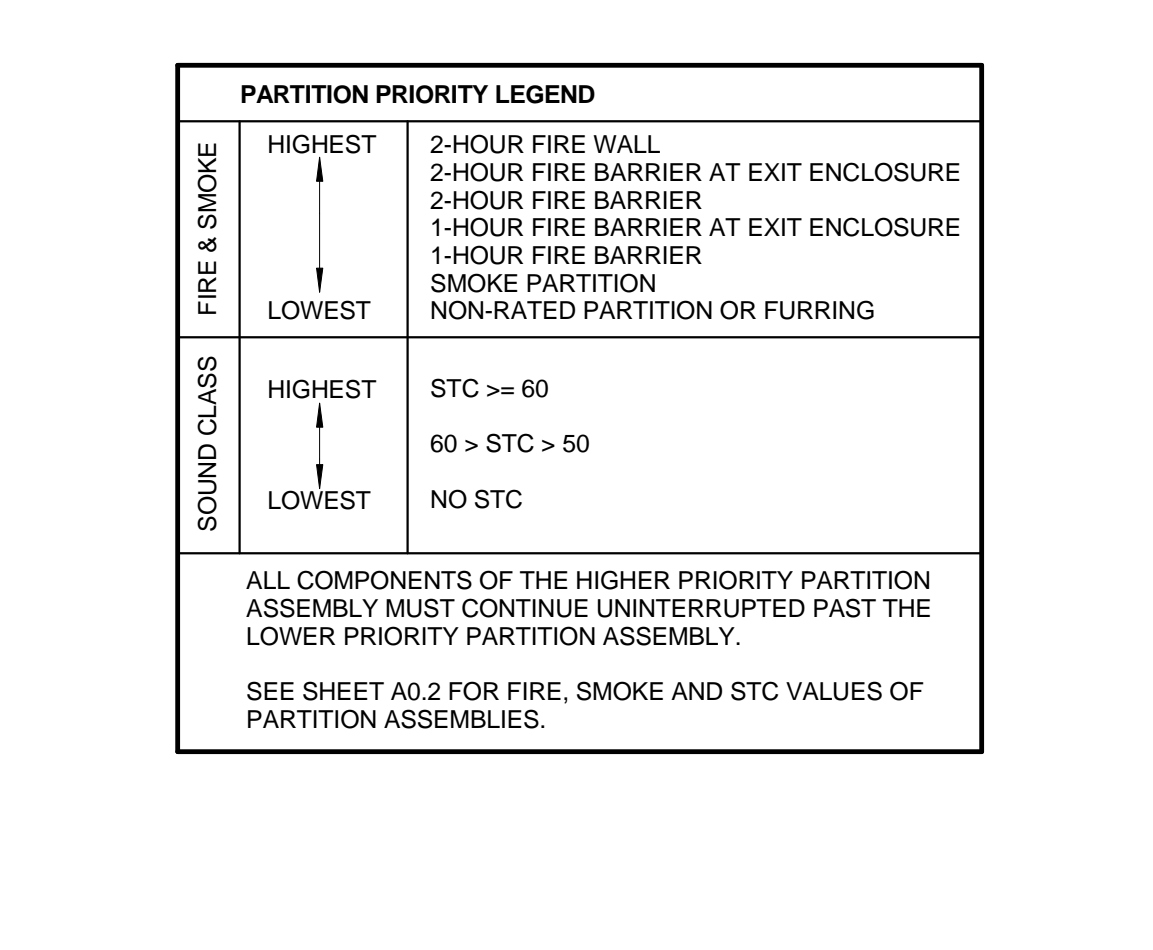

A3 PARTITION PRIORITY
1 1/2" = 1'-0"

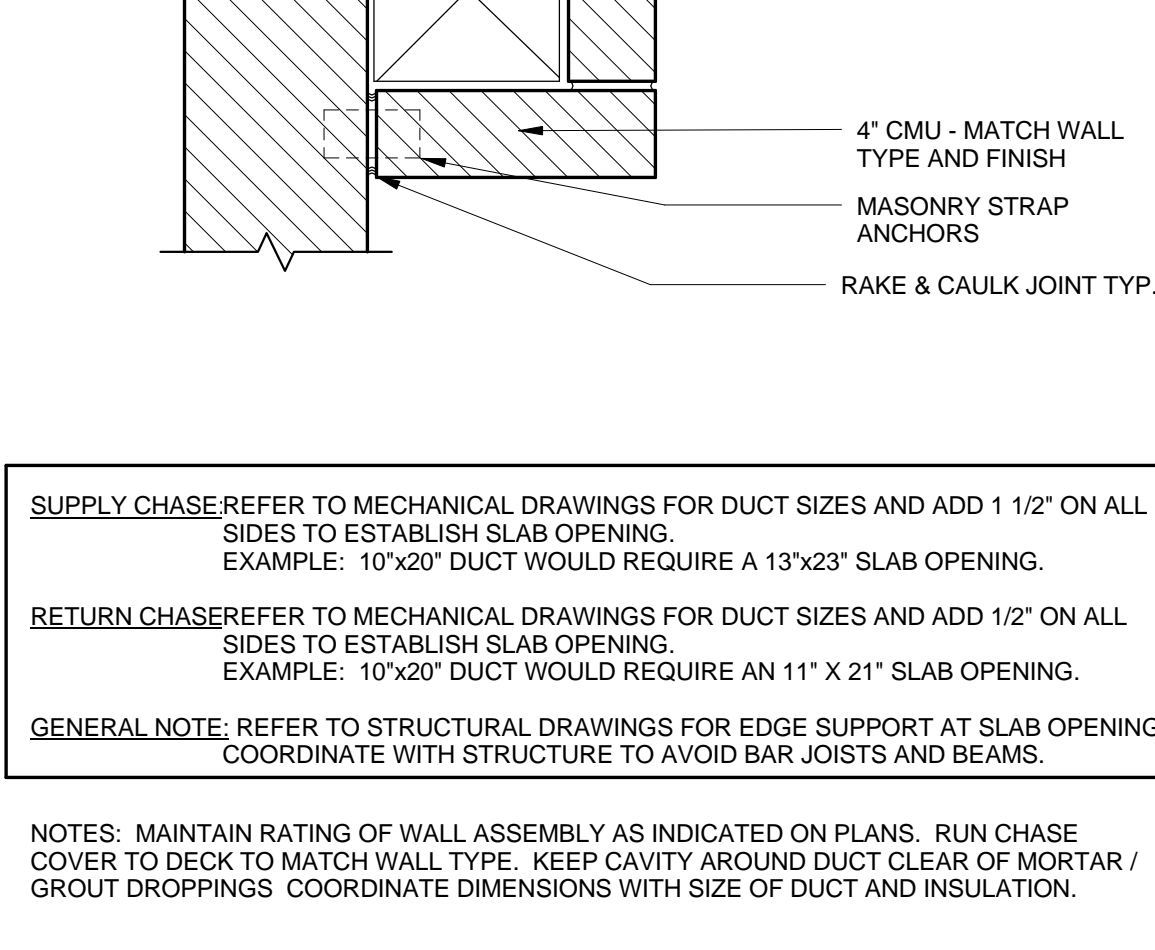

A2 CHASE AT INTERIOR PARTITION
1 1/2" = 1'-0"

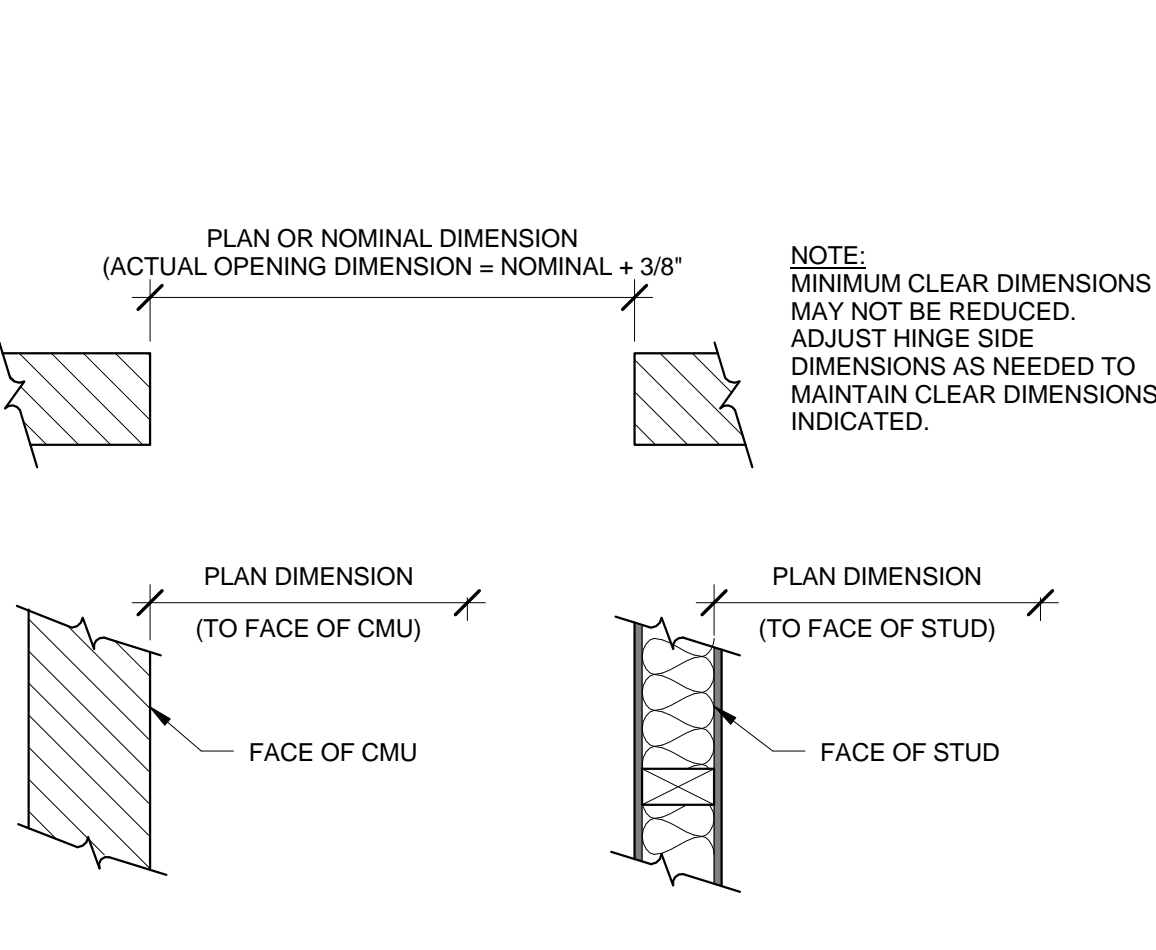

A1 DIMENSIONAL STANDARDS
1 1/2" = 1'-0"

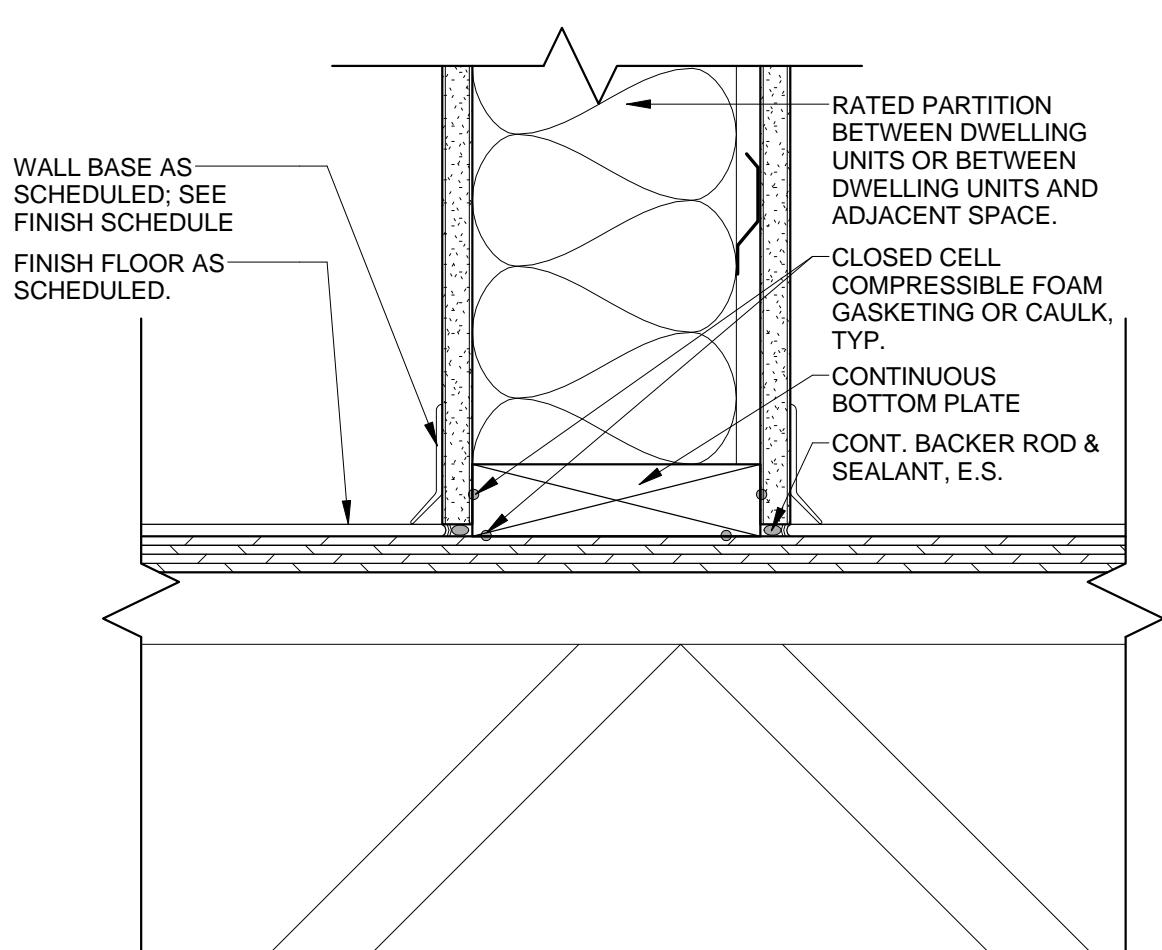

A6 COMPARTMENTALIZATION - PENETRATIONS
1 1/2" = 1'-0"