

E3 RAIN DIVERTER DETAIL
3" = 1'-0"

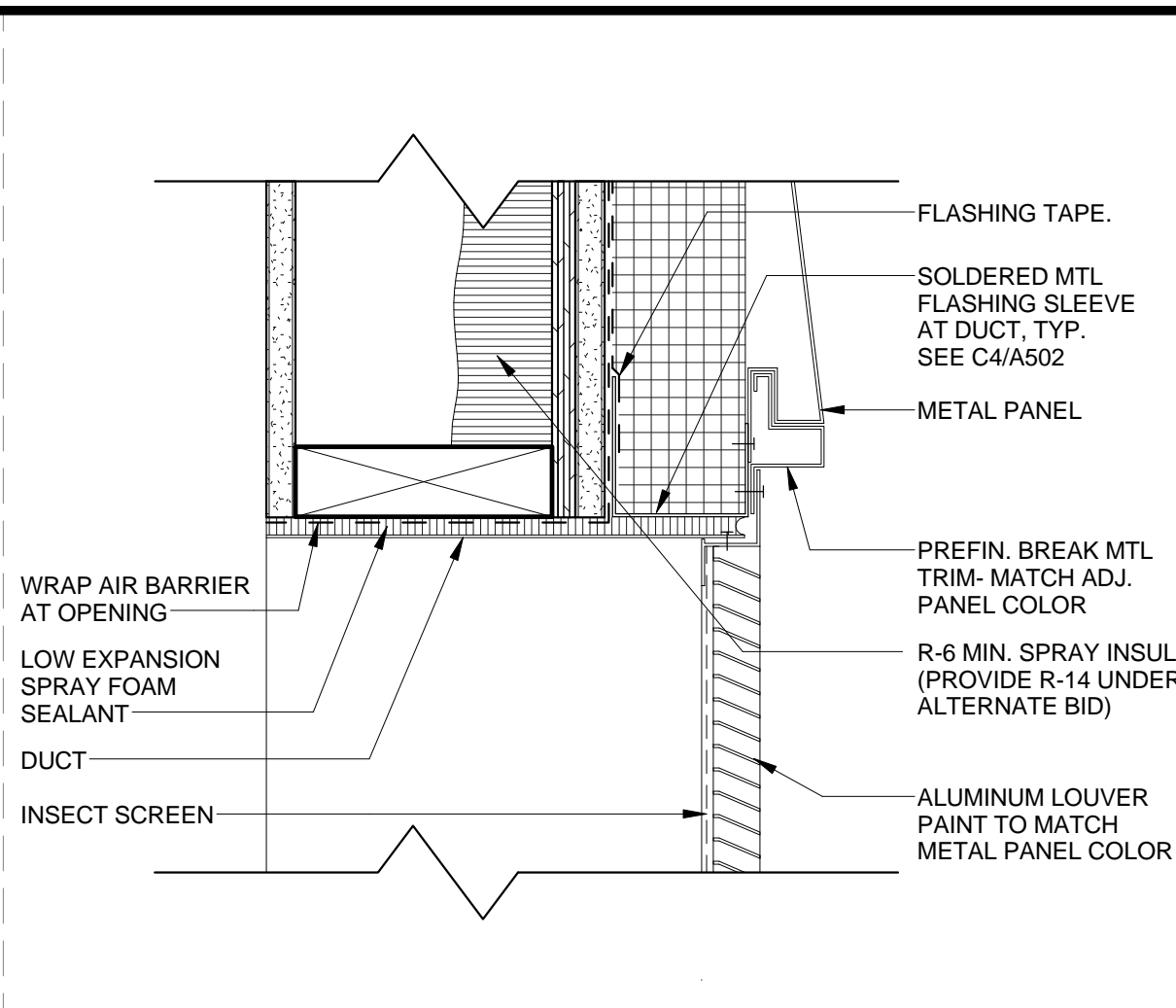

E4 LOUVER HEAD AT METAL PANEL
3" = 1'-0"

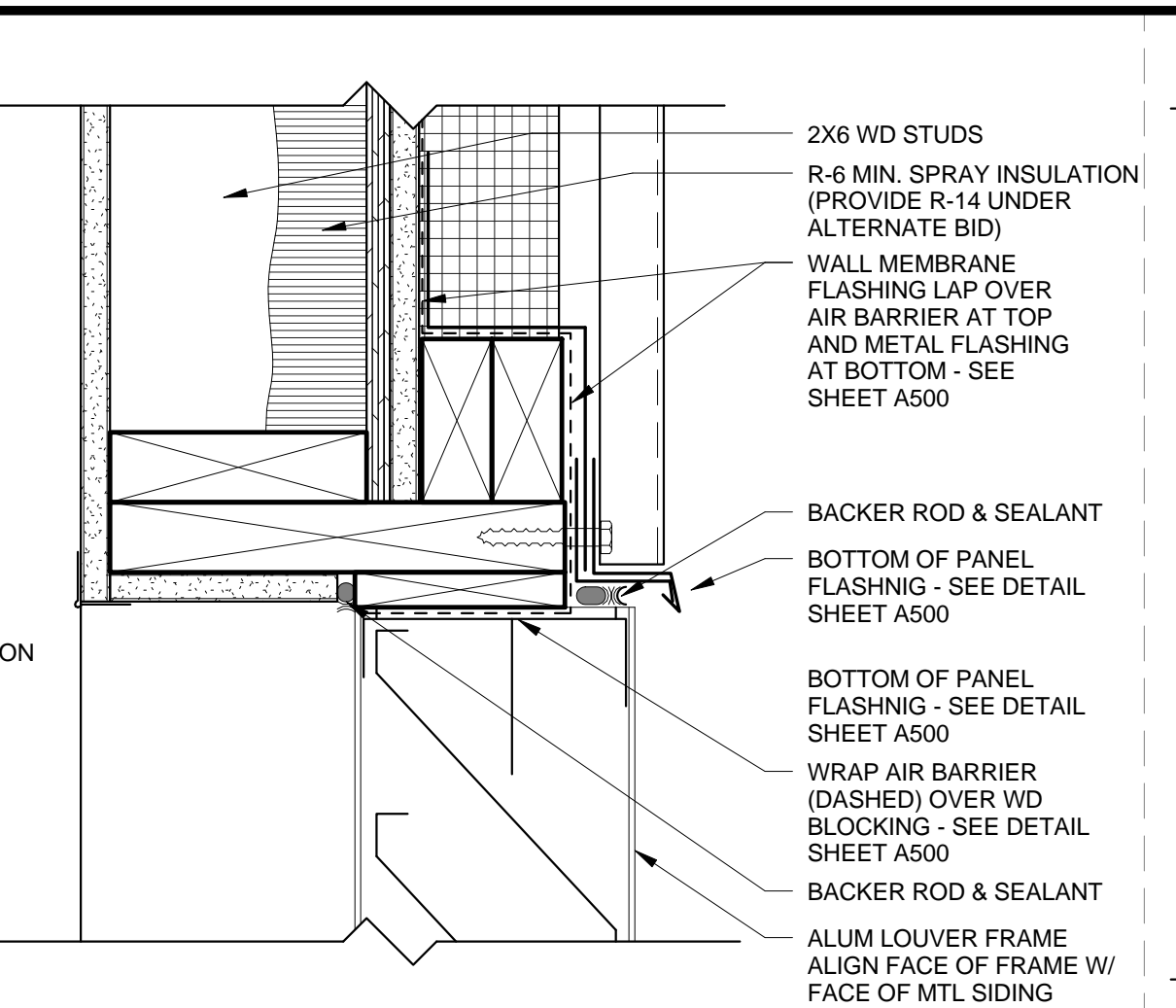

E3 LOUVER HEAD DETAIL AT METAL WALL PANEL
3" = 1'-0"

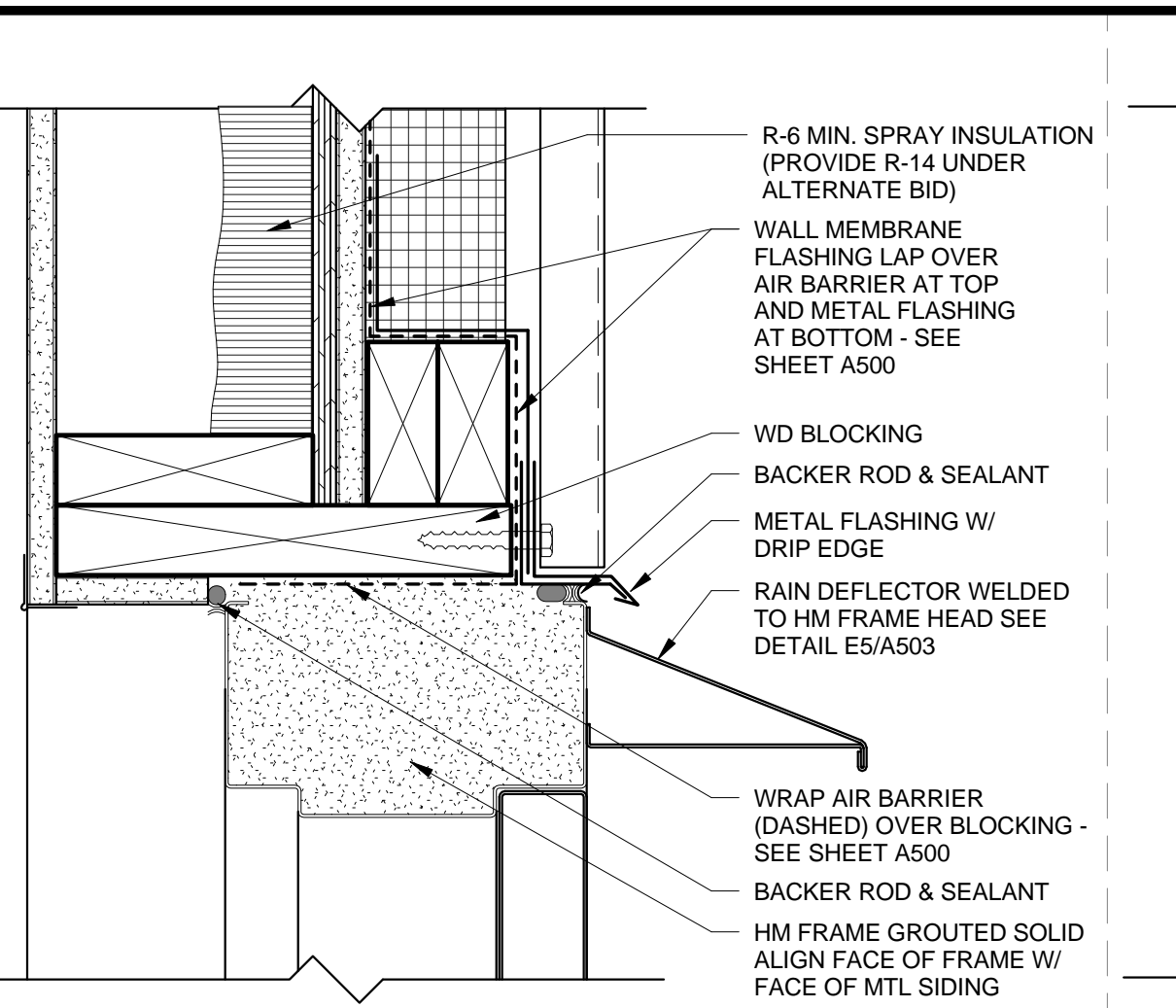

E2 DOOR HEAD DETAIL AT METAL PANEL
3" = 1'-0"

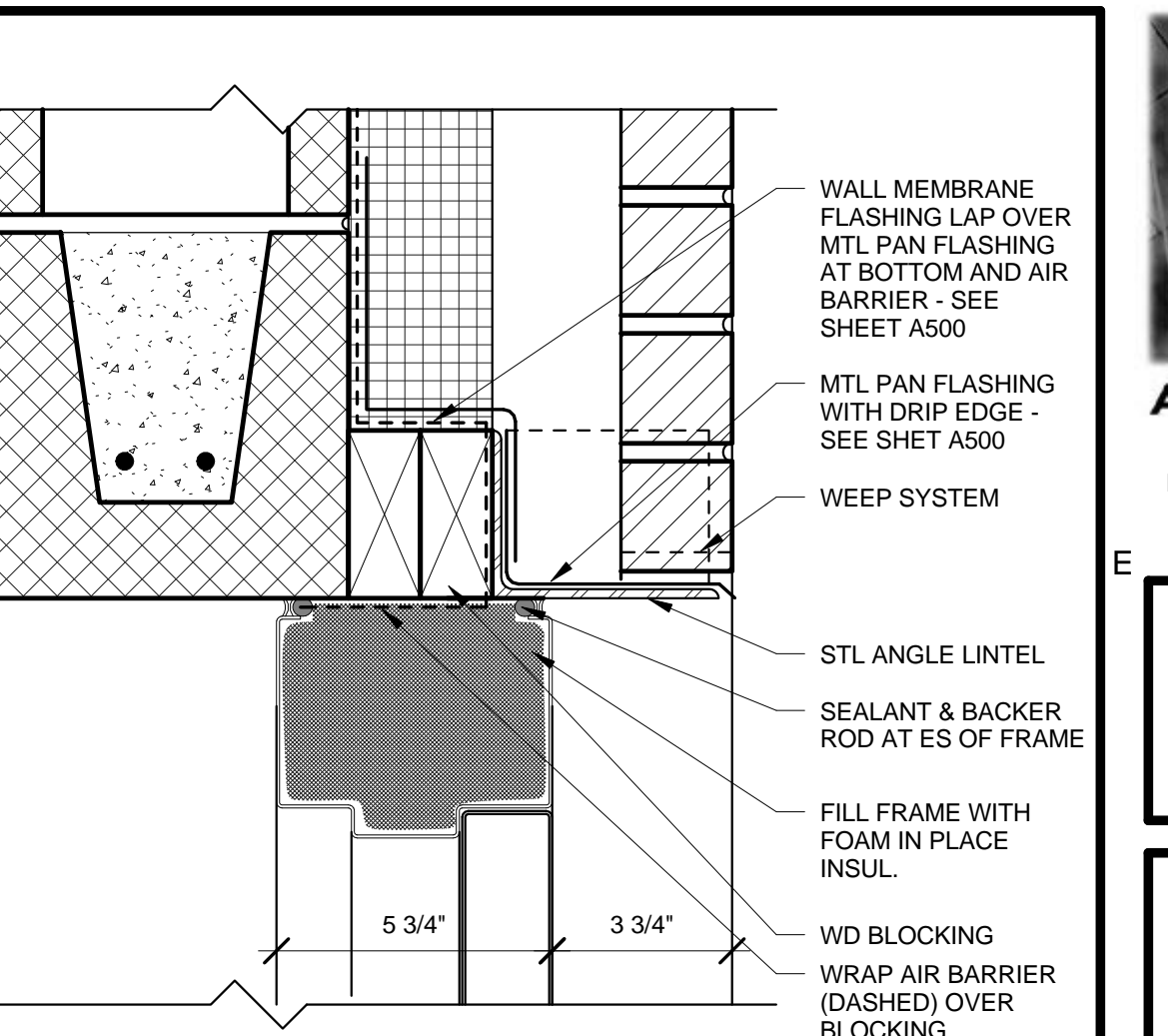

E1 DOOR HEAD DETAIL AT CMU AND BRICK
3" = 1'-0"

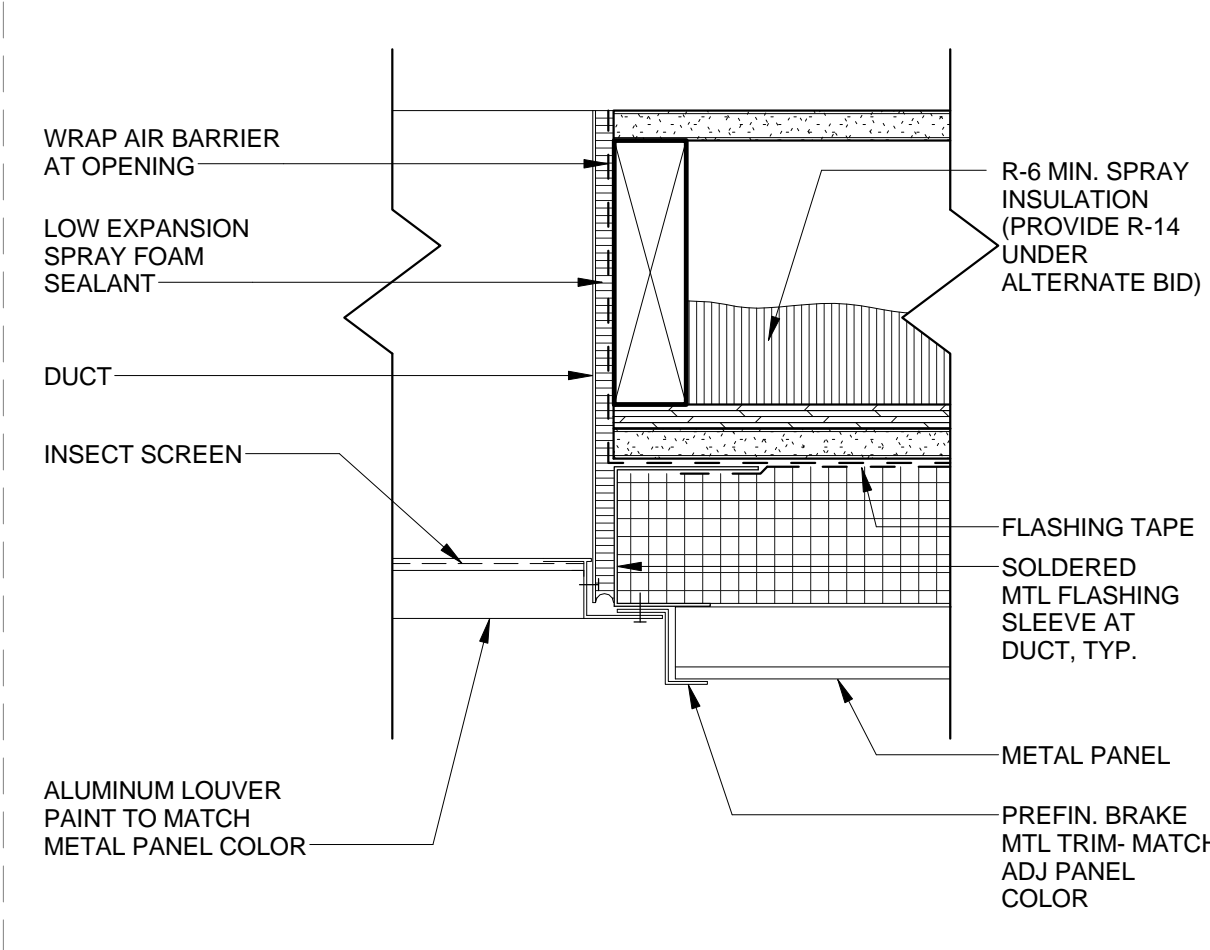

D4 EXHAUST LOUVER JAMB
3" = 1'-0"

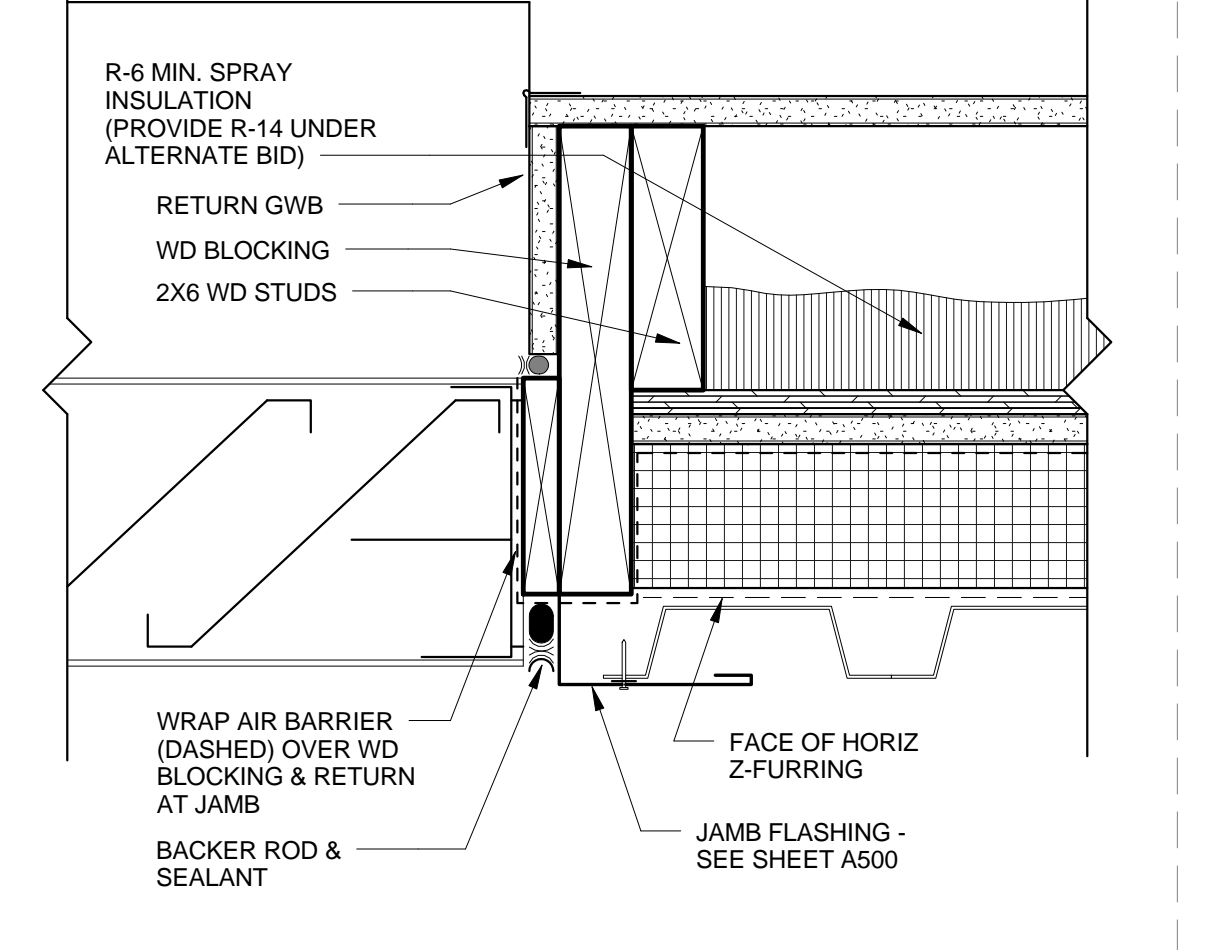

D3 LOUVER JAMB DETAIL AT METAL WALL PANEL
3" = 1'-0"

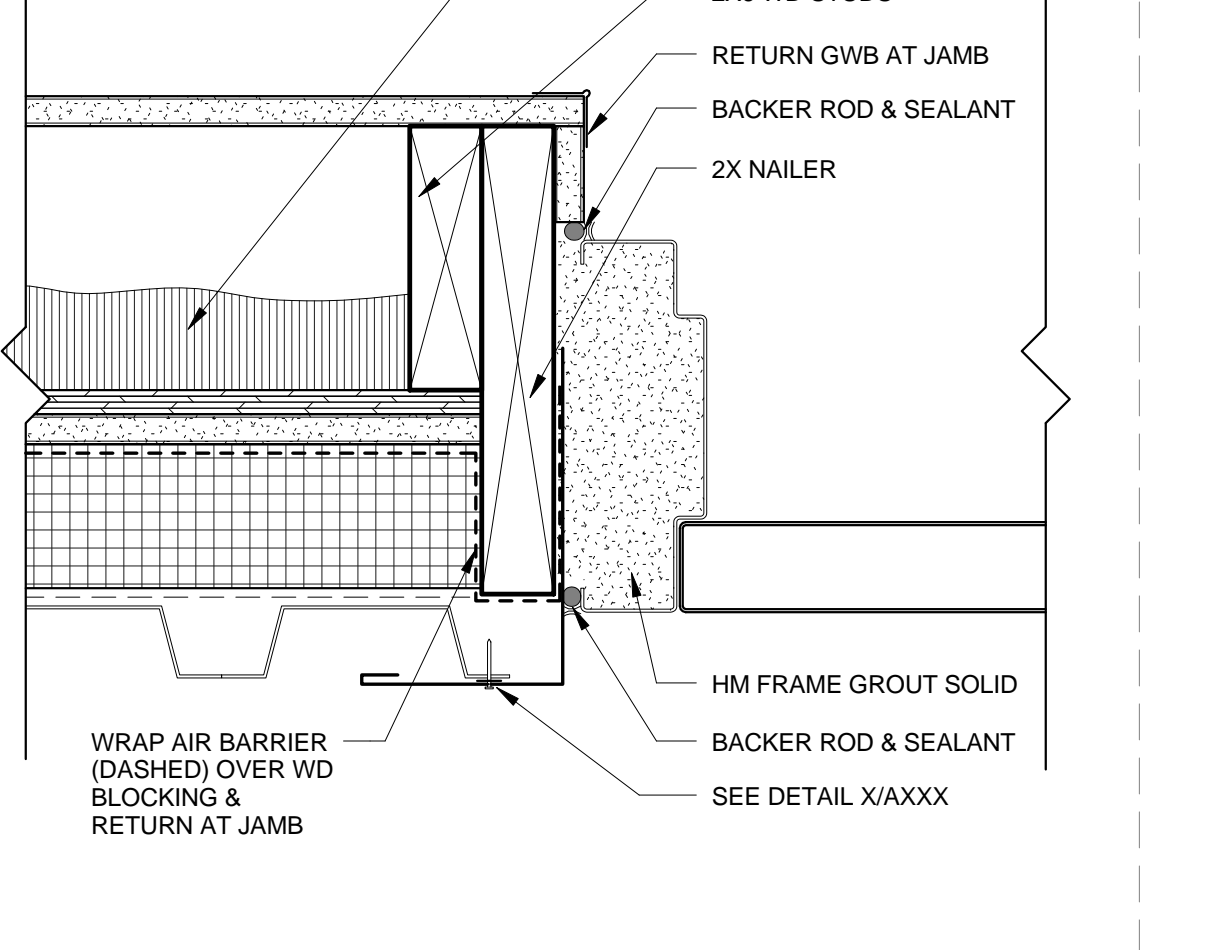

D2 DOOR JAMB DETAIL AT METAL PANEL
3" = 1'-0"

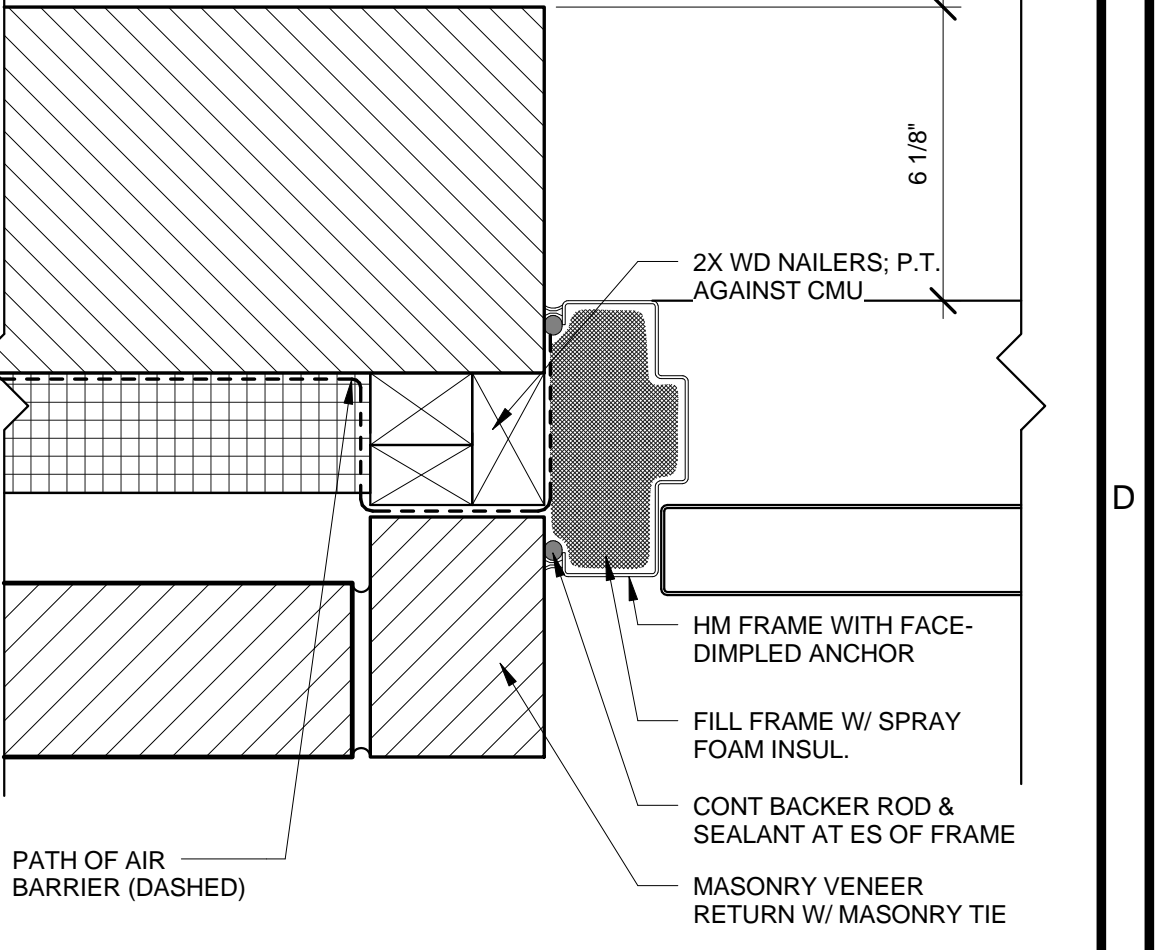

D1 DOOR JAMB DETAIL AT CMU AND BRICK
3" = 1'-0"

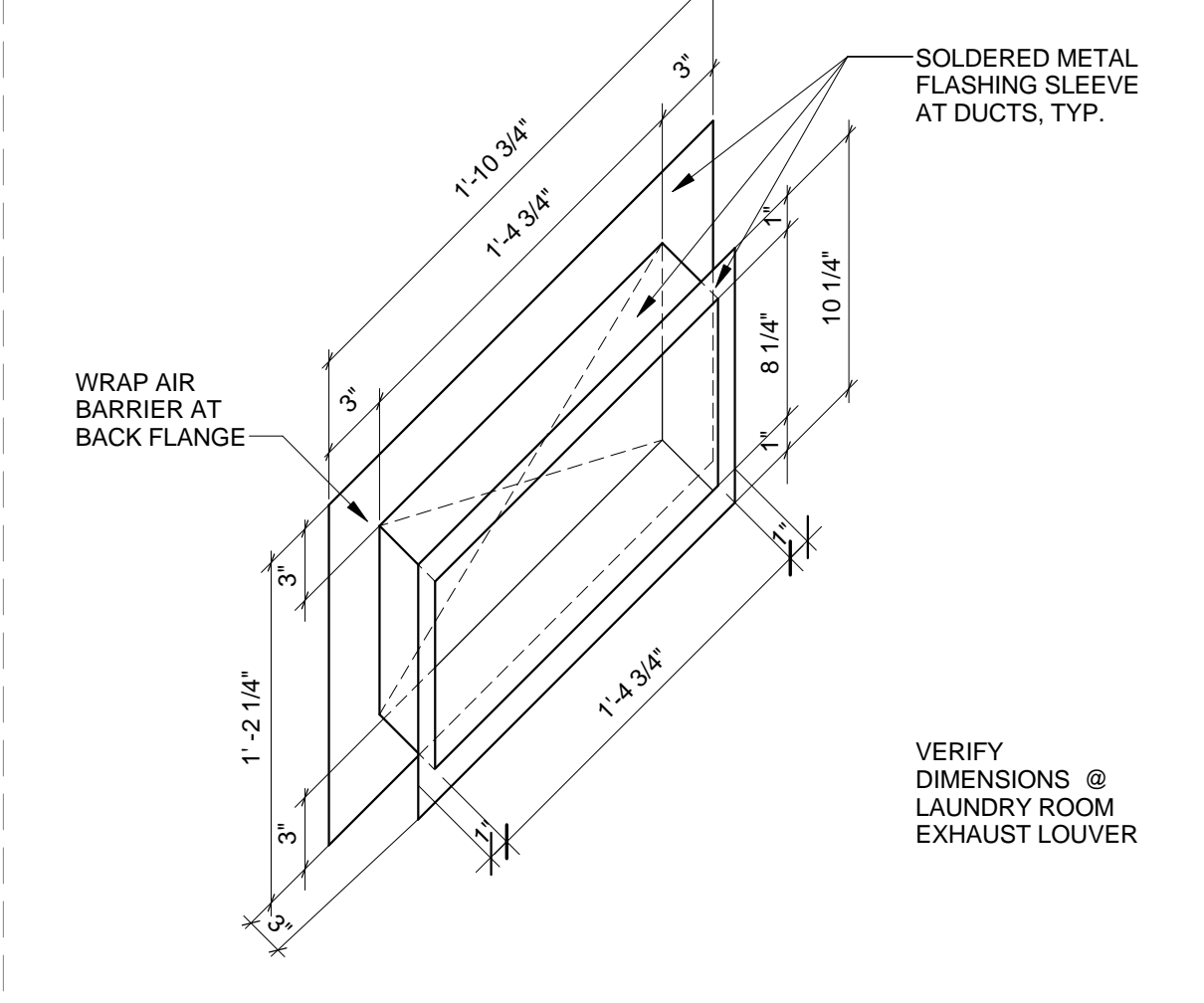

C4 FLASHING SLEEVE AT RANGE HOOD LOUVERS
1 1/2" = 1'-0"

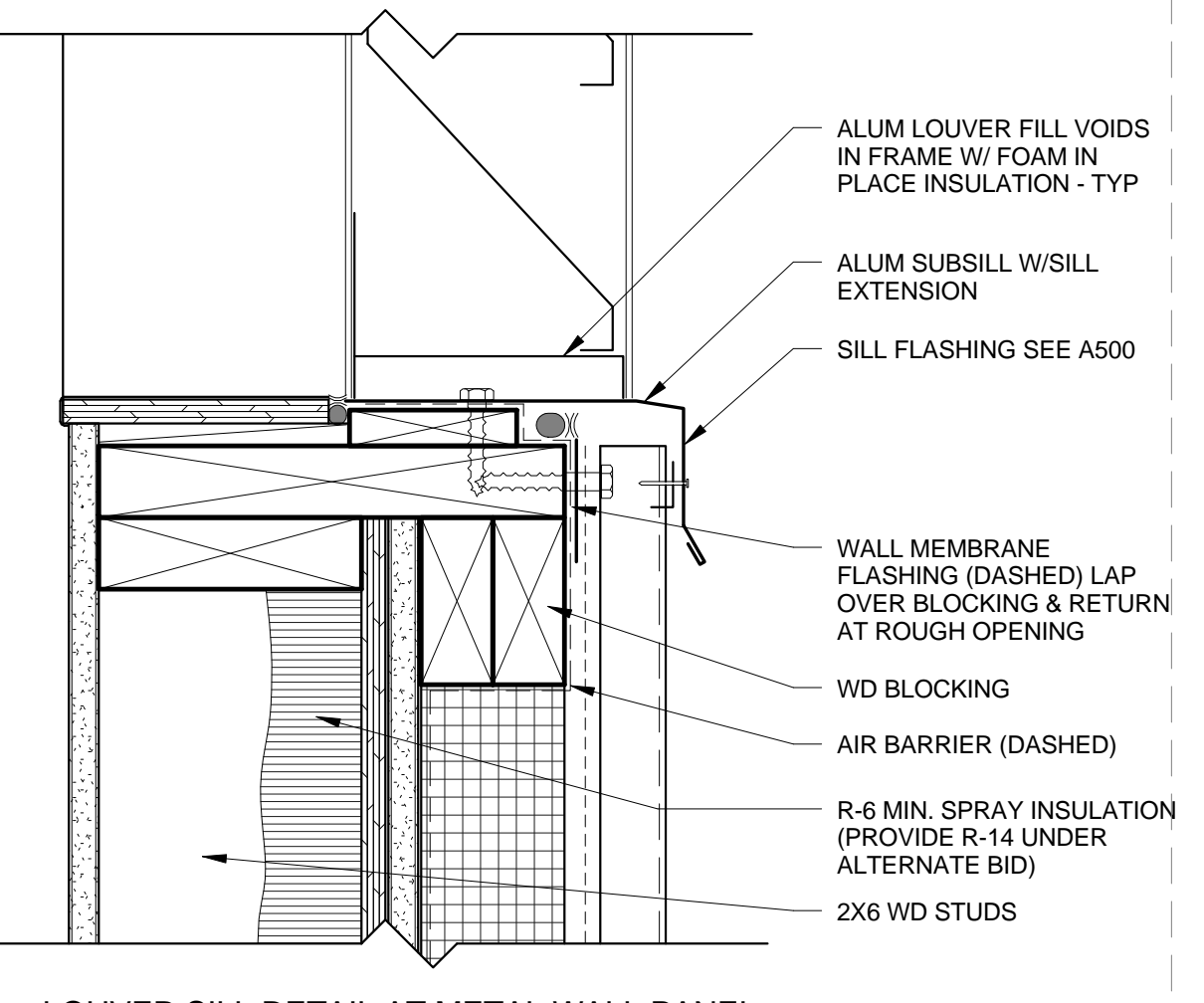

C3 LOUVER SILL DETAIL AT METAL WALL PANEL
3" = 1'-0"

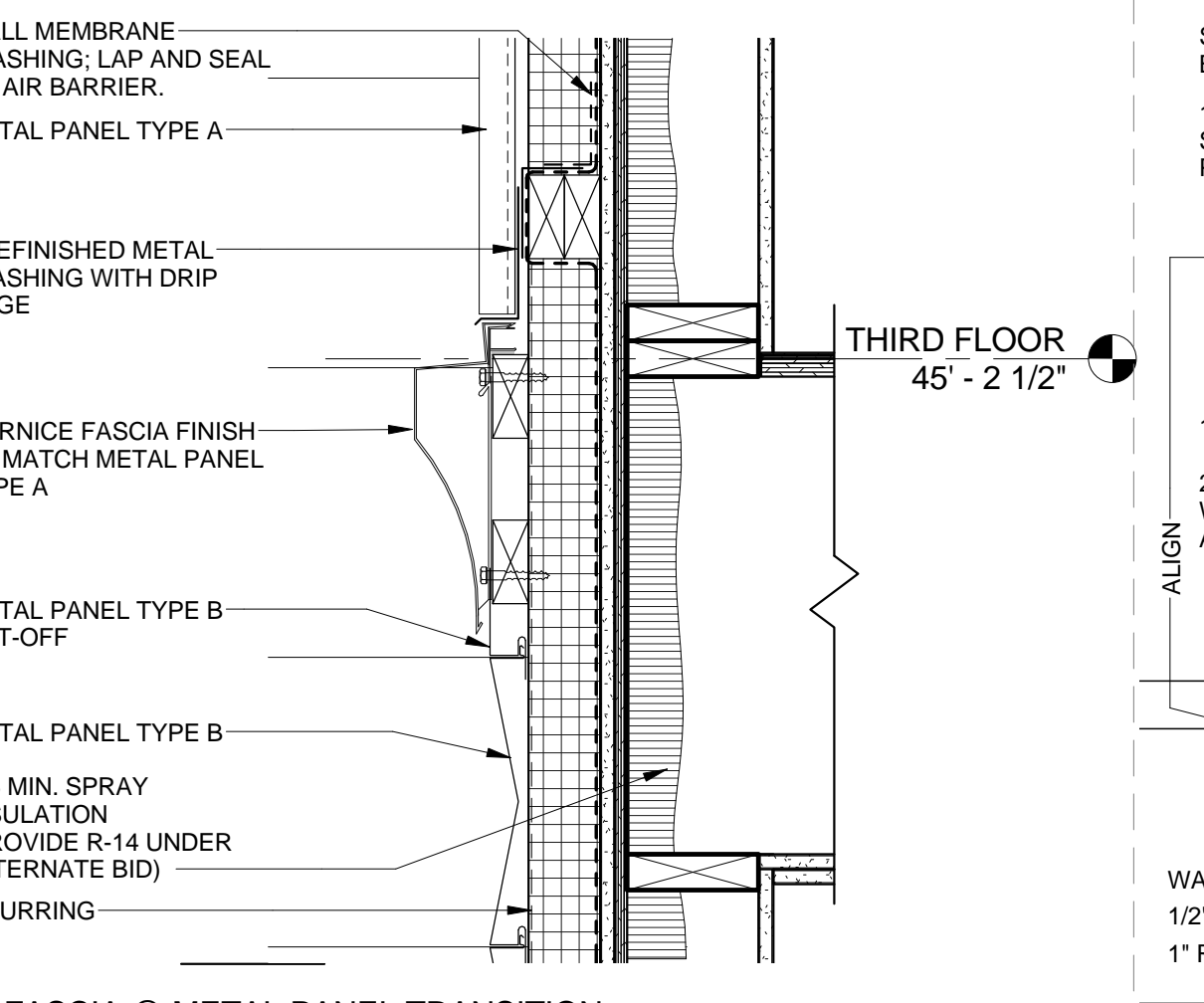

C2 FASCIA @ METAL PANEL TRANSITION
1 1/2" = 1'-0"

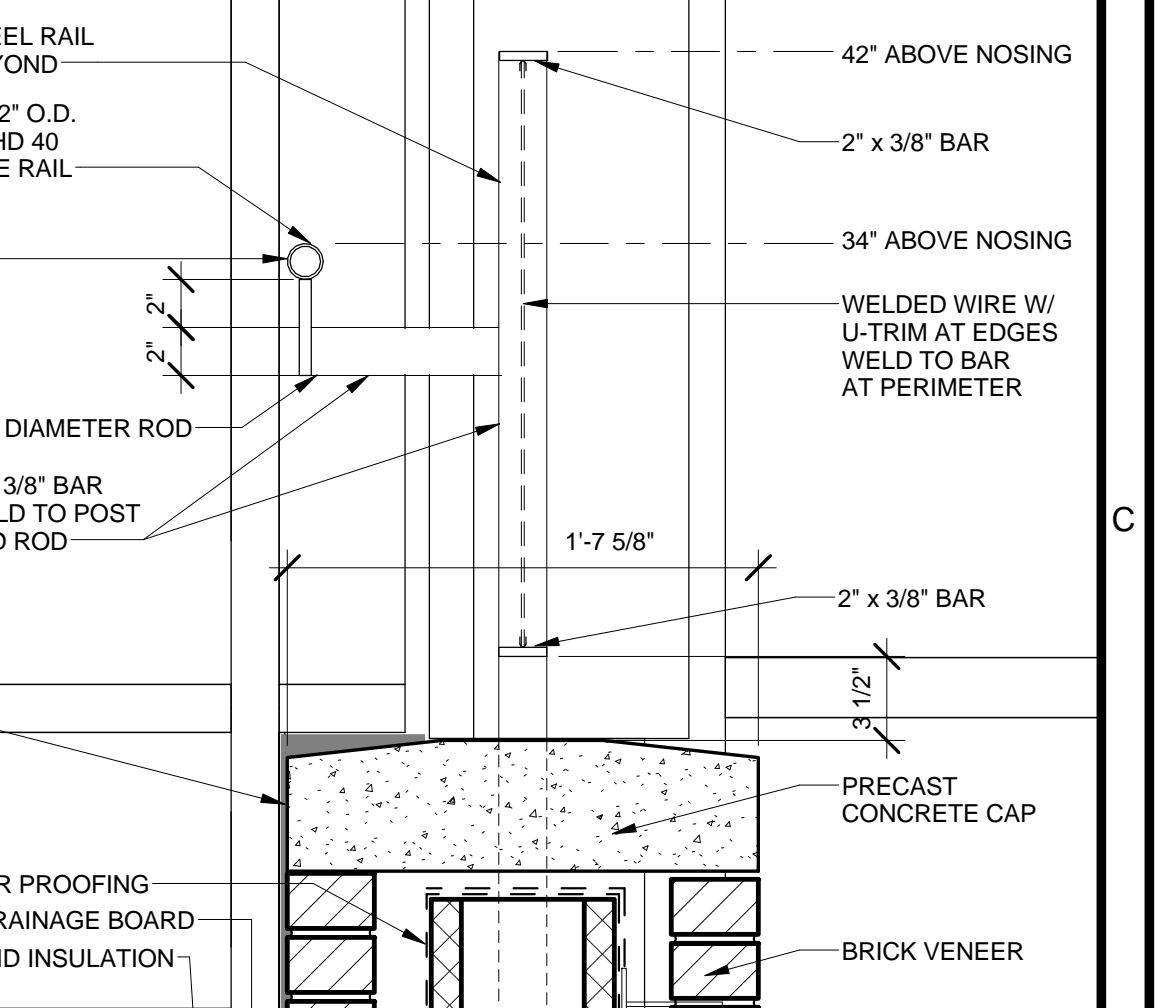

B1 RAILINGS AT LINK STAIR
1 1/2" = 1'-0"

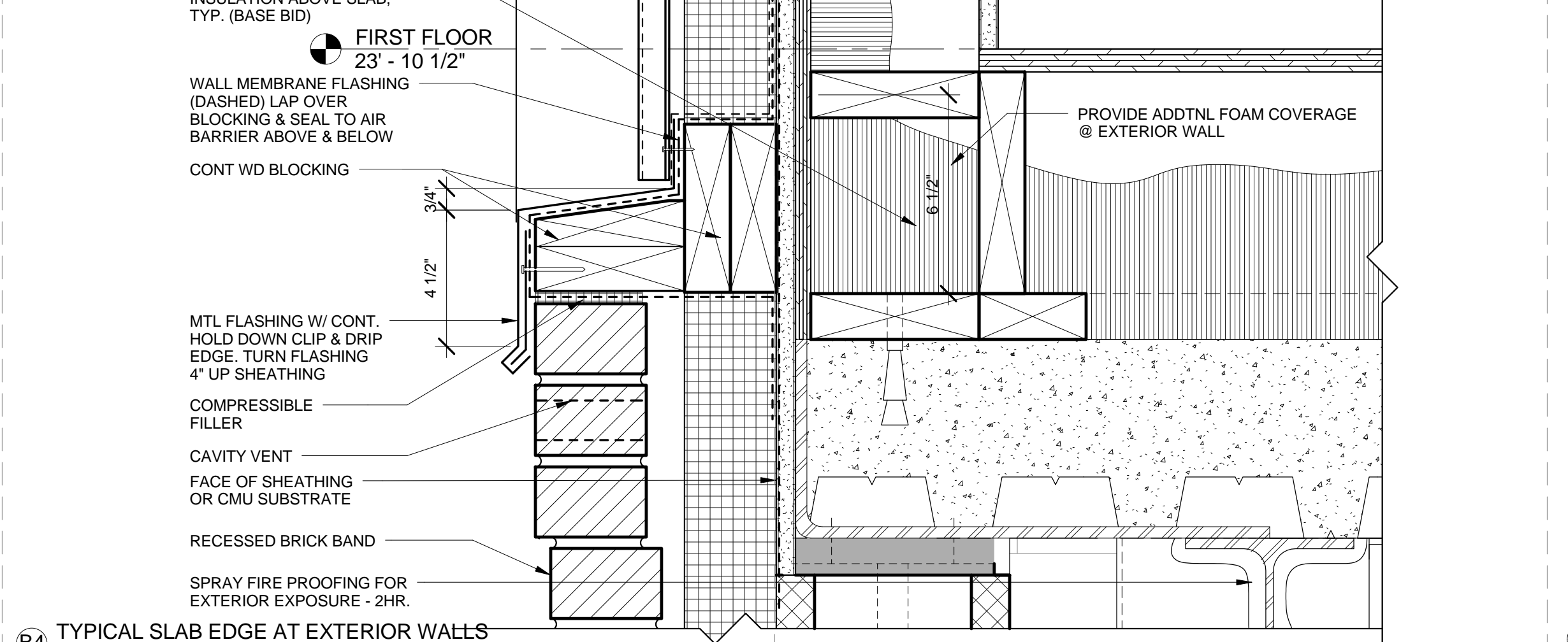

B4 TYPICAL SLAB EDGE AT EXTERIOR WALLS
3" = 1'-0"

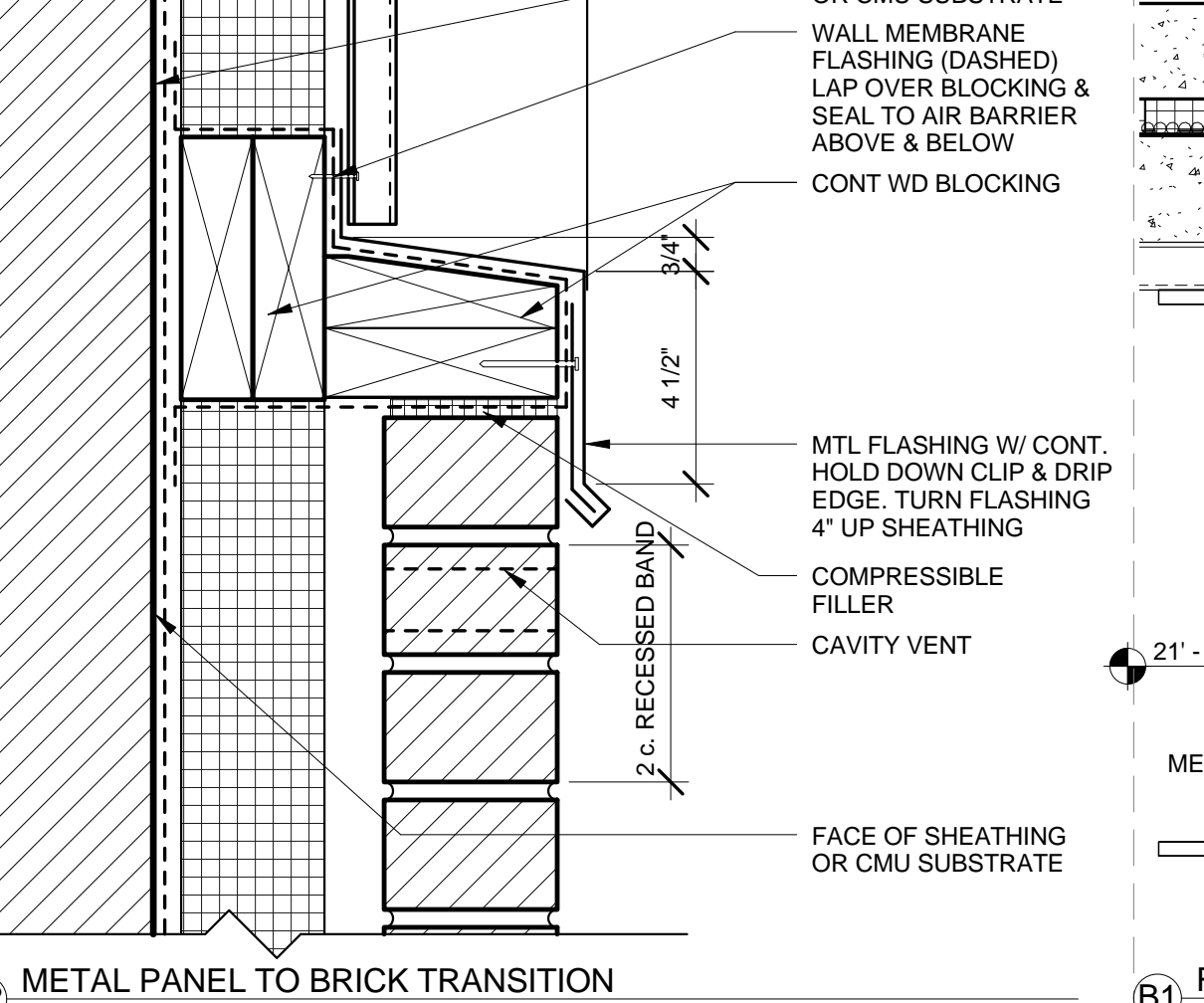

B2 METAL PANEL TO BRICK TRANSITION
3" = 1'-0"

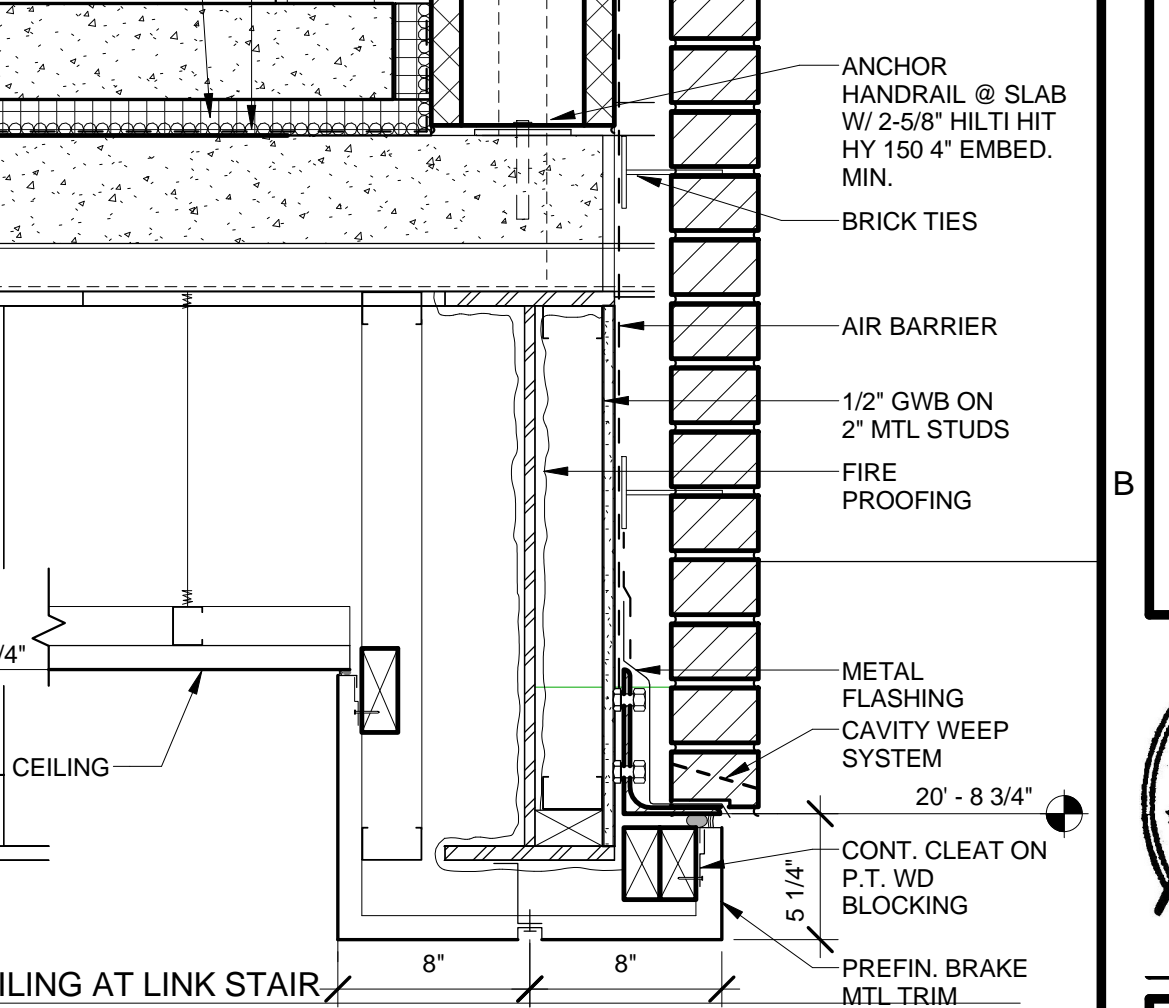

A2 BOTTOM OF EXTERIOR CMU WALL
1 1/2" = 1'-0"

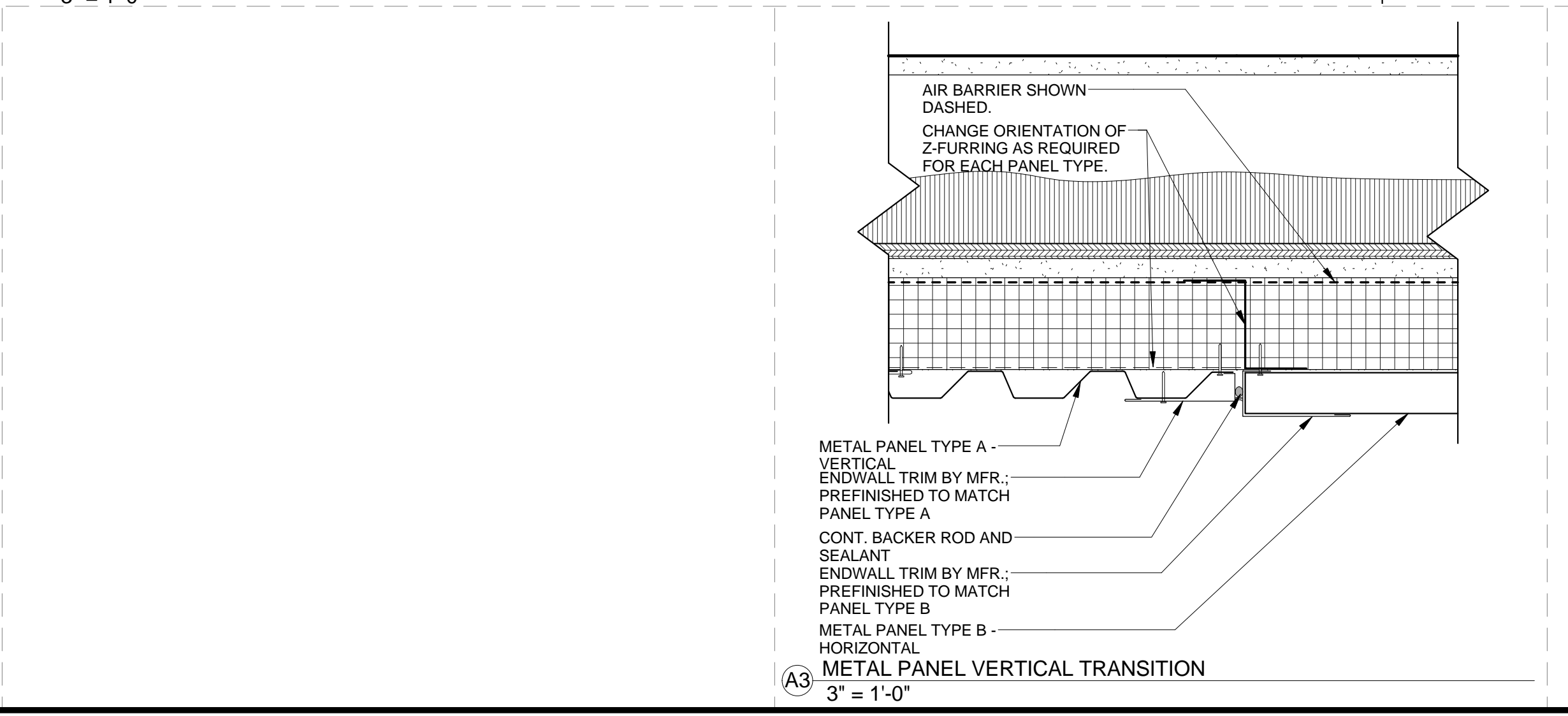

A3 METAL PANEL VERTICAL TRANSITION
3" = 1'-0"

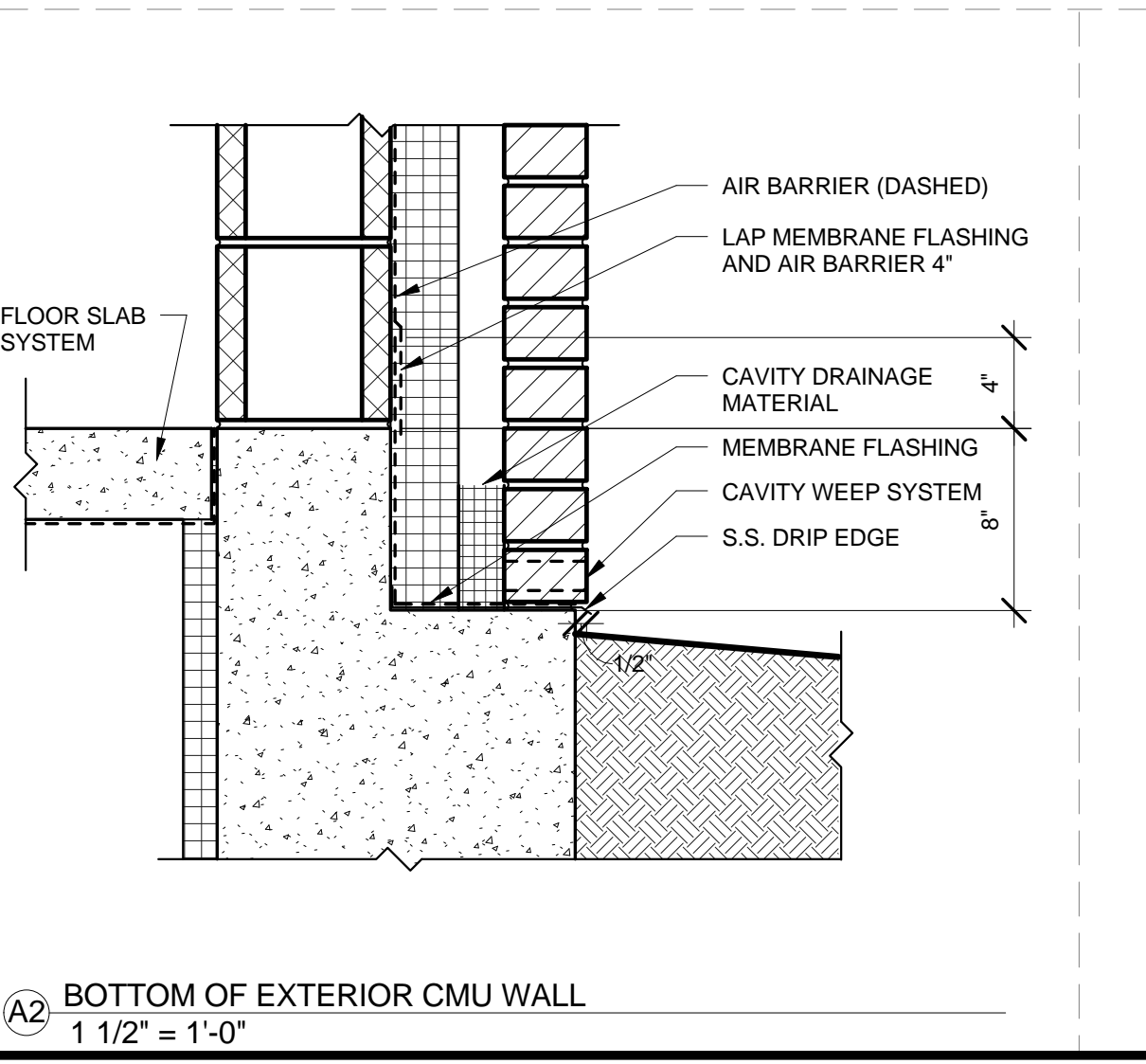

A2 BOTTOM OF EXTERIOR CMU WALL
1 1/2" = 1'-0"