

D6 ELEVATOR CAP DETAIL #2  
1 1/2" = 1'-0"

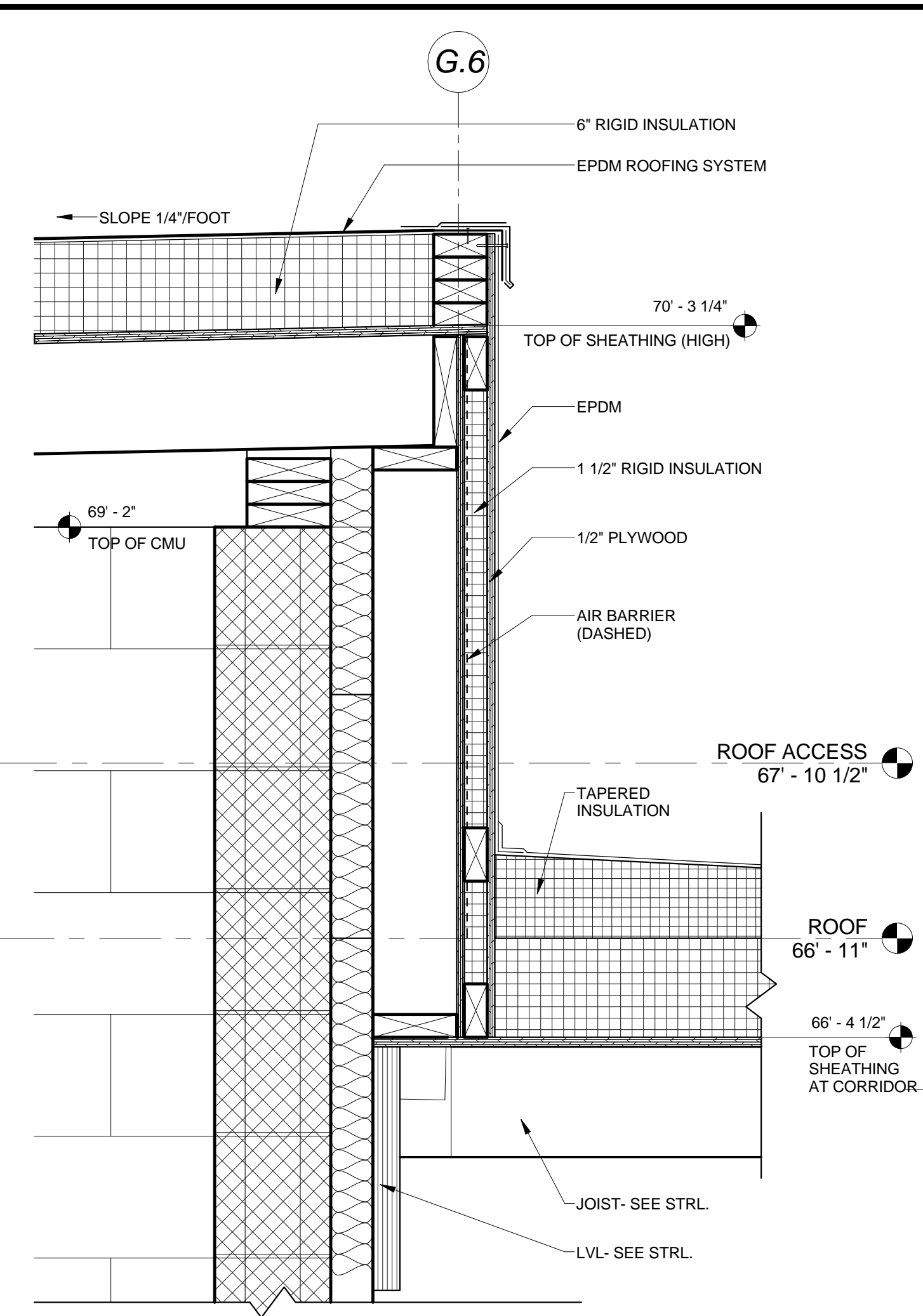

D5 ELEVATOR SHAFT CAP DETAIL  
1 1/2" = 1'-0"

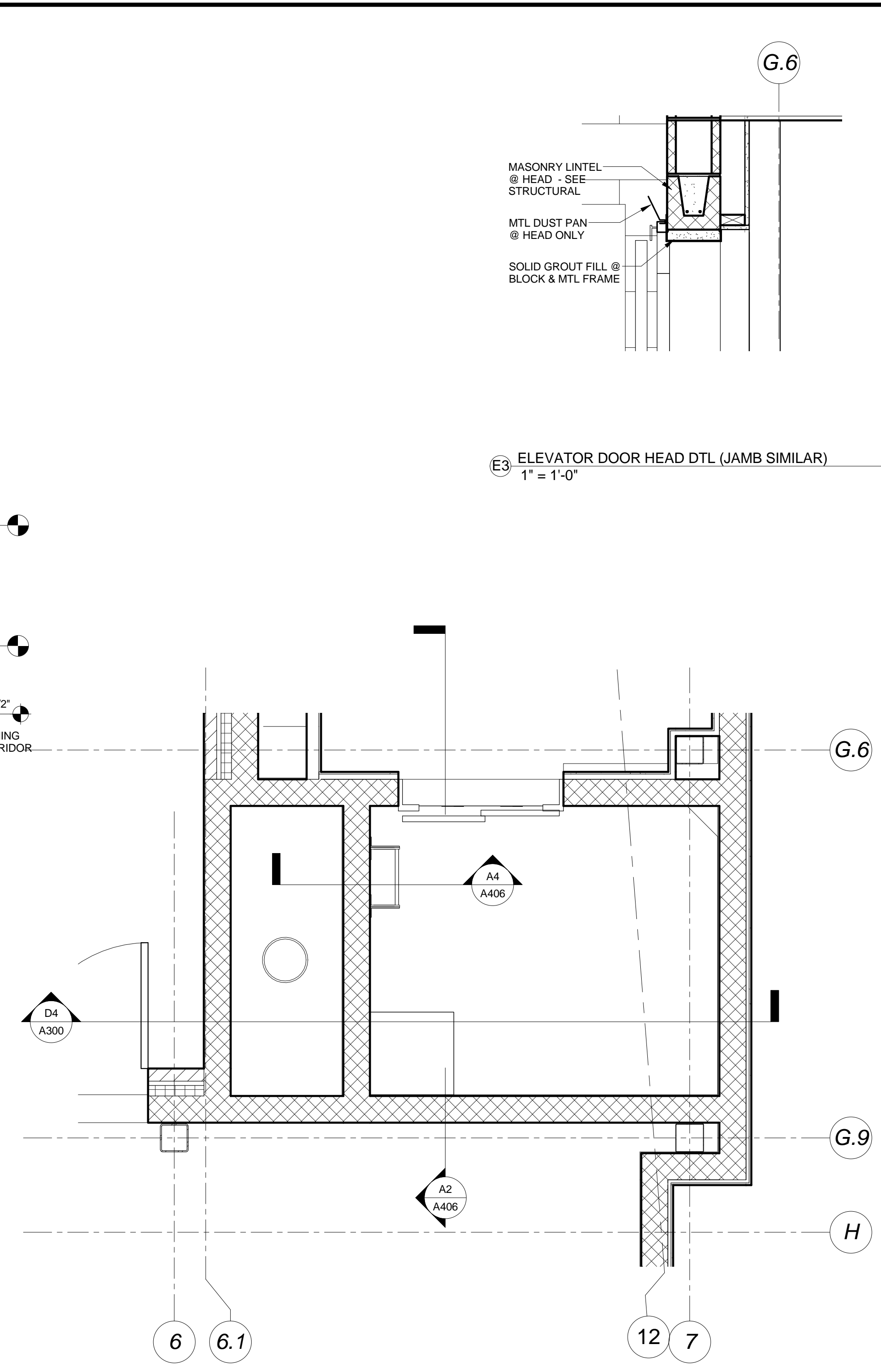

C4 ENLARGED ELEVATOR PLAN  
1/2" = 1'-0"

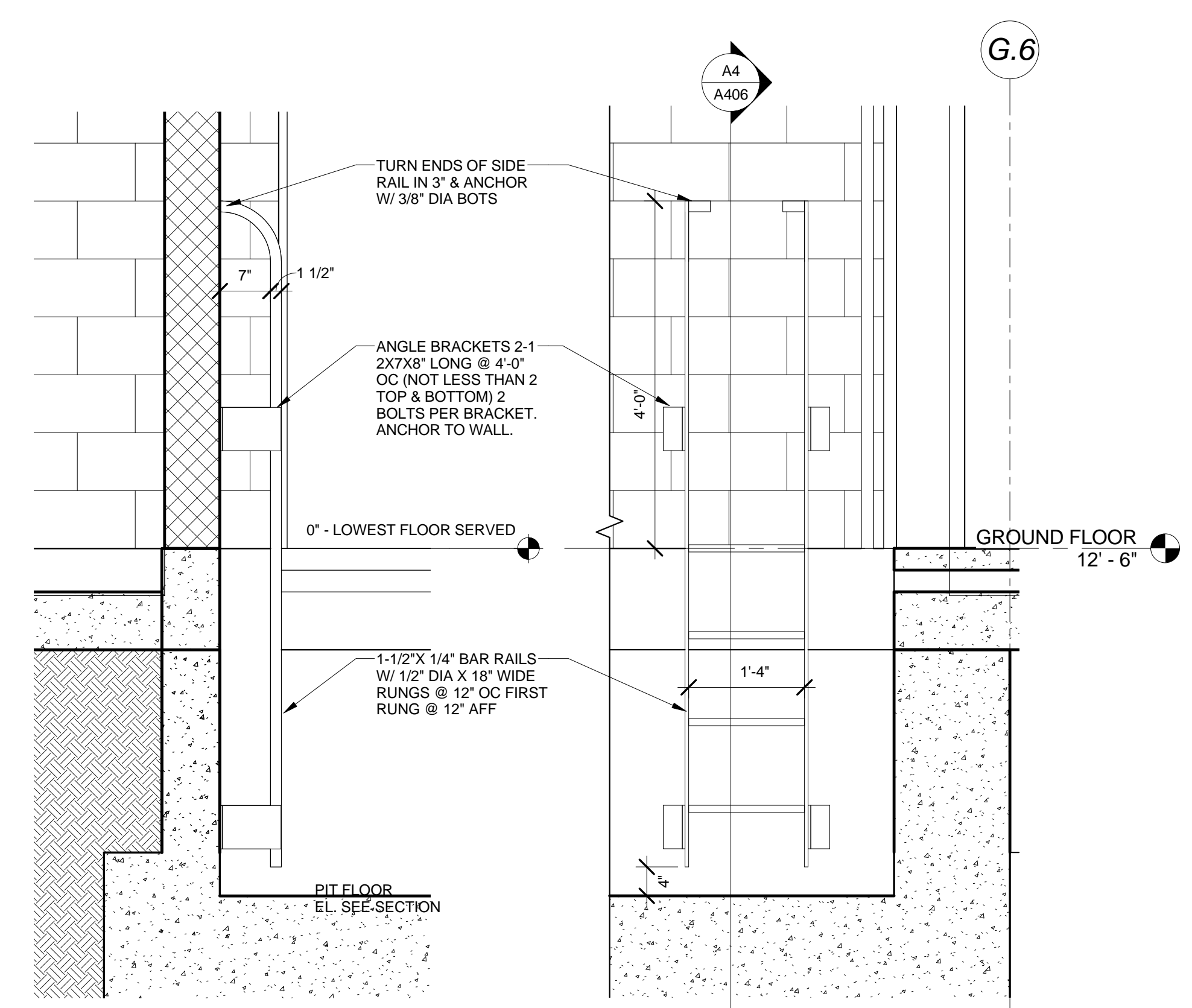

A4 ELEVATOR PIT LADDER  
3/4" = 1'-0"

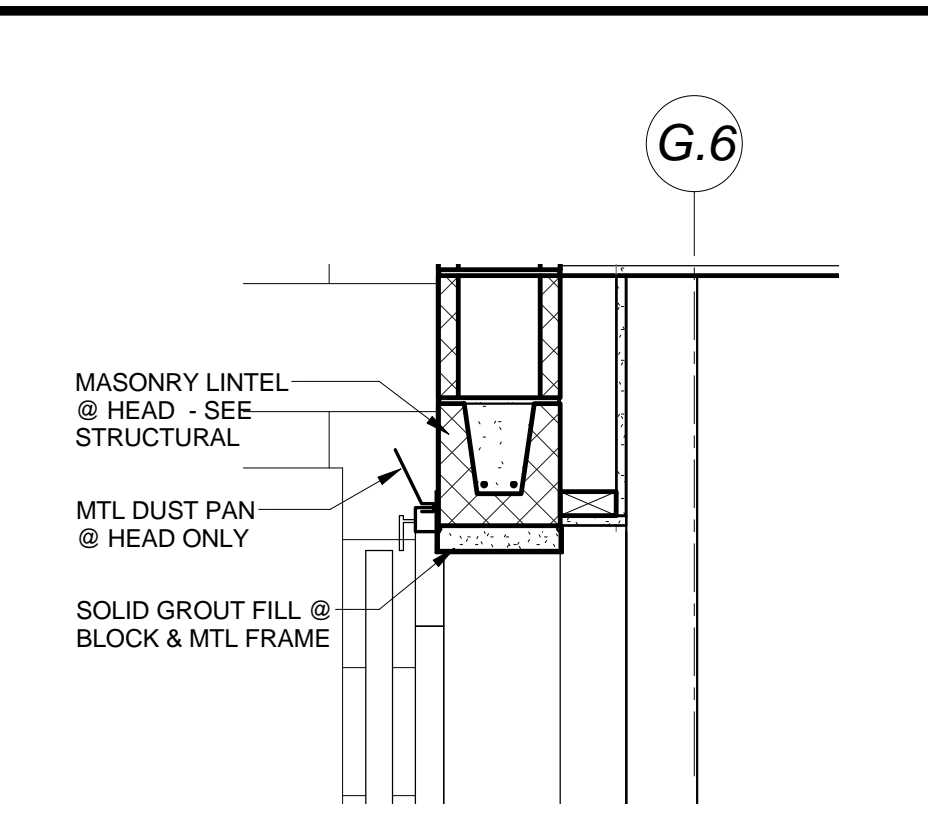

E3 ELEVATOR DOOR HEAD DETL (JAMB SIMILAR)  
1" = 1'-0"

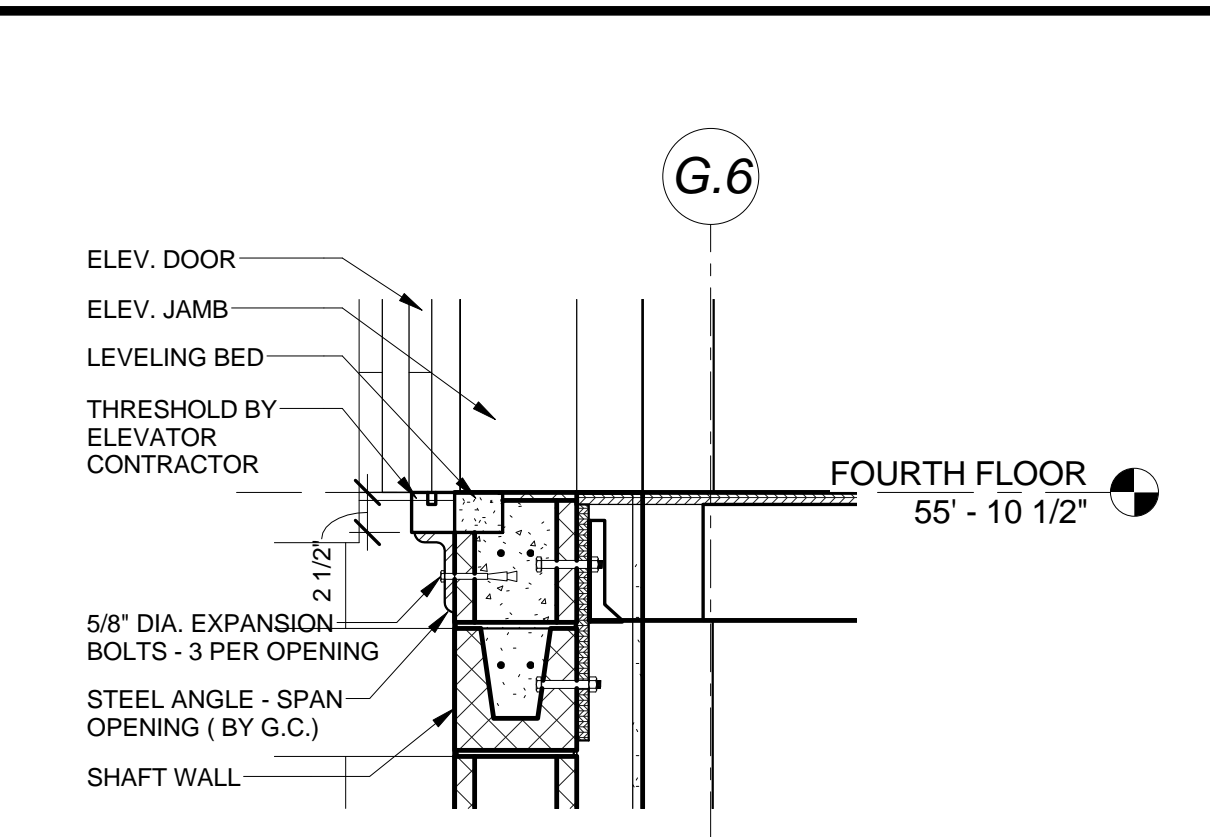

E2 ELEVATOR DOOR BASE DETAIL  
1" = 1'-0"

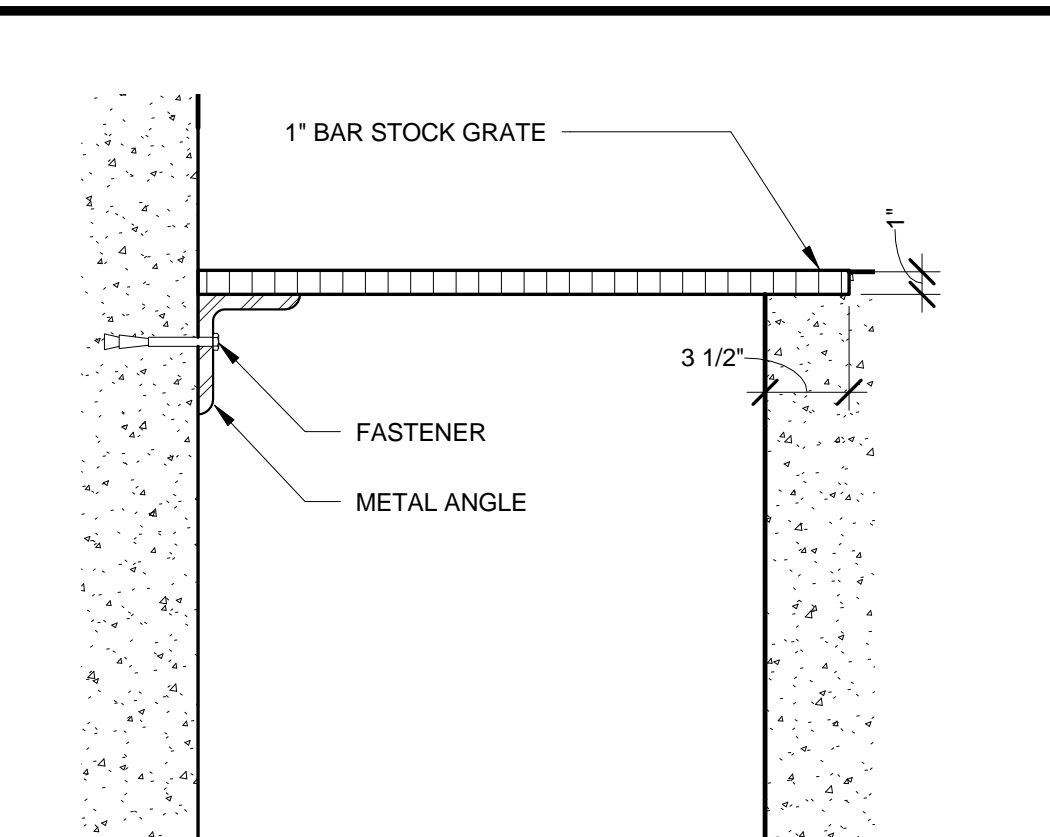

E1 ELEVATOR PIT GRATE SECTION  
1 1/2" = 1'-0"

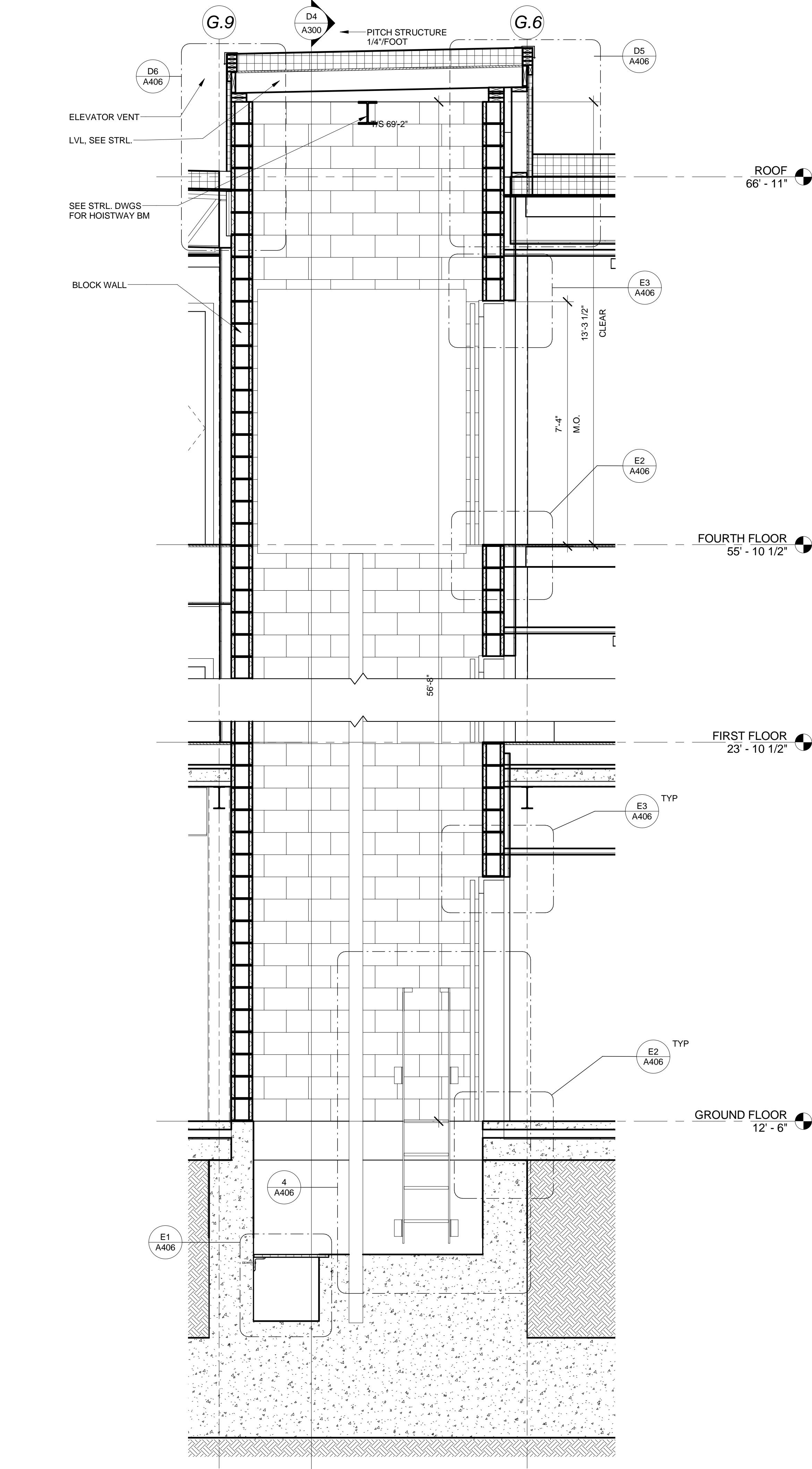

A2 ELEVATOR SECTION  
1/2" = 1'-0"