

# DISPLAY THIS CARD ON PRINCIPAL FRONTAGE OF WORK CITY OF PORTLAND

BUILDING DEPARTMENT

## PERMIT

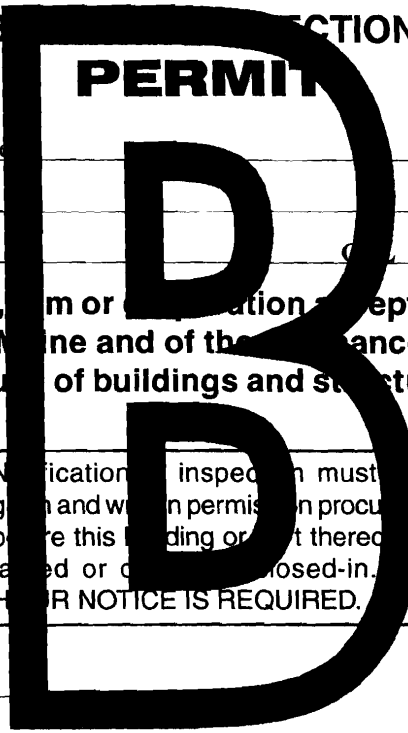

Please Read Application And Notes, If Any, Attached

PERMIT ISSUED  
Permit Number: 041859  
JAN - 6 2005  
CITY OF PORTLAND

This is to certify that Mardigan Edward L/R B Alle

has permission to Install a fire alarm system

AT 54 Chestnut St

026 C005001

provided that the person or persons, firm or corporation accepting this permit shall comply with all of the provisions of the Statutes of Maine and of the ordinances of the City of Portland regulating the construction, maintenance and use of buildings and structures, and of the application on file in this department.

Apply to Public Works for street line and grade if nature of work requires such information.

Notification of inspection must be given and work on permit in progress before this building or part thereof is occupied or closed-in. 48 HOUR NOTICE IS REQUIRED.

A certificate of occupancy must be procured by owner before this building or part thereof is occupied.

### OTHER REQUIRED APPROVALS

Fire Dept. *[Signature]*  
Health Dept. \_\_\_\_\_  
Appeal Board \_\_\_\_\_  
Other \_\_\_\_\_

Department Name

*[Signature]*  
Director - Building & Inspection Services  
*1/5/05*

**PENALTY FOR REMOVING THIS CARD**

**City of Portland, Maine - Building or Use Permit Application**

389 Congress Street, 04101 Tel: (207) 874-8703, Fax: (207) 874-8716

Permit No:	04-1859	Issue Date:	JAN - 6 2005	BL:	026 C005001
------------	---------	-------------	--------------	-----	-------------

Location of Construction: 54 Chestnut St	Owner Name: Mardigan Edward L	Owner Address: 11 Bayview Ter	Phone:
Business Name:	Contractor Name: R B Allen	Contractor Address: 53 Egypt Rd Gray	Phone: 572457
Lessee/Buyer's Name	Phone:	Permit Type: Fire Alarm System	Zone:

Past Use: commercial	Proposed Use: commercial Install a fire alarm system	Permit Fee: \$165.00	Cost of Work: \$15,284.00	CEO District: 1
Proposed Project Description: Install a fire alarm system		FIRE DEPT: <input checked="" type="checkbox"/> Approved <input type="checkbox"/> Denied	INSPECTION: Use Group: <i>N/A</i> Type: <i>ALARM</i> <i>1/5/05</i>	
		Signature: <i>[Signature]</i>	Signature:	
PEDESTRIAN ACTIVITIES DISTRICT (P.A.D.)				
Action: <input type="checkbox"/> Approved <input type="checkbox"/> Approved w/Conditions <input type="checkbox"/> Denied				
		Signature:	Date:	

Permit Taken By: dmartin	Date Applied For: 12/27/2004	<b>Zoning Approval</b>		
-----------------------------	---------------------------------	------------------------	--	--

<p>1. This permit application does not preclude the Applicant(s) from meeting applicable State and Federal Rules.</p> <p>2. Building permits do not include plumbing, septic or electrical work.</p> <p>3. Building permits are void if work is not started within six (6) months of the date of issuance. False information may invalidate a building permit and stop all work..</p>	<p><b>Special Zone or Reviews</b></p> <p><input type="checkbox"/> Shoreland</p> <p><input type="checkbox"/> Wetland</p> <p><input type="checkbox"/> Flood Zone</p> <p><input type="checkbox"/> Subdivision</p> <p><input type="checkbox"/> Site Plan</p> <p>Maj <input type="checkbox"/> Minor <input type="checkbox"/> MM <input type="checkbox"/></p> <p>Date:</p>	<p><b>Zoning Appeal</b></p> <p><input type="checkbox"/> Variance</p> <p><input type="checkbox"/> Miscellaneous</p> <p><input type="checkbox"/> Conditional Use</p> <p><input type="checkbox"/> Interpretation</p> <p><input type="checkbox"/> Approved</p> <p><input type="checkbox"/> Denied</p> <p>Date:</p>	<p><b>Historic Preservation</b></p> <p><input type="checkbox"/> Not in District or Landmark</p> <p><input type="checkbox"/> Does Not Require Review</p> <p><input type="checkbox"/> Requires Review</p> <p><input type="checkbox"/> Approved</p> <p><input type="checkbox"/> Approved w/Conditions</p> <p><input type="checkbox"/> Denied</p> <p>Date:</p>
---	--	--	--

**CERTIFICATION**

I hereby certify that I am the owner of record of the named property, or that the proposed work is authorized by the owner of record and that I have been authorized by the owner to make this application as his authorized agent and I agree to conform to all applicable laws of this jurisdiction. In addition, if a permit for work described in the application is issued, I certify that the code official's authorized representative shall have the authority to enter all areas covered by such permit at any reasonable hour to enforce the provision of the code(s) applicable to such permit.

SIGNATURE OF APPLICANT \_\_\_\_\_ ADDRESS \_\_\_\_\_ DATE \_\_\_\_\_ PHONE \_\_\_\_\_

RESPONSIBLE PERSON IN CHARGE OF WORK, TITLE \_\_\_\_\_ DATE \_\_\_\_\_ PHONE \_\_\_\_\_

**City of Portland, Maine - Building or Use Permit**

389 Congress Street, 04101 Tel: (207) 874-8703, Fax: (207) 874-8716

<b>Permit No:</b> 04-1859	<b>Date Applied For:</b> 12/27/2004	<b>CBL:</b> 026 C005001
------------------------------	--	----------------------------

<b>Location of Construction:</b> 54 Chestnut St	<b>Owner Name:</b> Mardigan Edward L	<b>Owner Address:</b> 11 Bayview Ter	<b>Phone:</b>
<b>Business Name:</b>	<b>Contractor Name:</b> R B Allen	<b>Contractor Address:</b> 53 Egypt Rd Gray	<b>Phone</b> (207) 657-2457
<b>Lessee/Buyer's Name</b>	<b>Phone:</b>	<b>Permit Type:</b> Fire Alarm System	

<b>Proposed Use:</b> commercial Install a fire alarm system	<b>Proposed Project Description:</b> Install a fire alarm system
--	---

**Dept:** Building      **Status:** Approved      **Reviewer:** Mike Nugent      **Approval Date:** 01/05/2005  
**Note:**      **Ok to Issue:**

**Dept:** Fire      **Status:** Approved with Conditions      **Reviewer:** Lt. MacDougal      **Approval Date:** 01/05/2005  
**Note:**      **Ok to Issue:**

- 1) the fire alarm system shall be tested to NFPA 72 standards and the results submitted to the Portland Fire Department
- 2) the fire alarm system shall be installed in accordance with NFPA 72 standards

# All Purpose Building Permit Application

If you or the property owner owes real estate or personal property taxes or user charges on any property within the City, payment arrangements must be made before permits of any kind are accepted.

Location/Address of Construction: <u>54 Chestnut St Portland ME</u>		
Total Square Footage of Proposed Structure <u>3000?</u>	Square Footage of Lot	
Tax Assessor's Chart, Block & Lot Chart# <u>26</u> Block# <u>C</u> Lot# <u>005</u>	Owner: <u>City of Portland</u>	Telephone:
Lessee/Buyer's Name (If Applicable)	Applicant name, address & telephone:	Cost Of Work: <u>\$15284.00</u> Fee: \$ <u>165.00</u>
Current use: <u>Family shelter</u>		<div style="border: 2px solid black; padding: 5px; width: fit-content; margin: auto;"> <p style="margin: 0;">DEPT. OF BUILDING INSPECTION CITY OF PORTLAND, ME</p> <div style="border: 1px solid black; padding: 5px; margin: 5px auto; width: 80%;"> <p style="margin: 0; font-weight: bold; font-size: 1.2em;">DEC 27 2004</p> </div> <p style="margin: 0; font-weight: bold; font-size: 1.5em;">RECEIVED</p> </div>
If the location is currently vacant, what was prior use: <u>-</u>		
Approximately how long has it been vacant: <u>-</u>		
Proposed use: <u>Family shelter</u> Project description: <u>Install Fire Alarm System</u>		
Contractor's name, address & telephone:		
Who should we contact when the permit is ready: <u>Tim Birin R B Allen 657-2457</u>		
Mailing address: <u>RB Allen 53 EGYPT RD GRAY ME 04039</u>		
We will contact you by phone when the permit is ready. You must come in and pick up the permit and review the requirements before starting any work, with a Plan Reviewer. A stop work order will be issued and a \$100.00 fee if any work starts before the permit is picked up. <b>PHONE:</b> <u>207 657 2457</u>		

**IF THE REQUIRED INFORMATION IS NOT INCLUDED IN THE SUBMISSIONS THE PERMIT WILL BE AUTOMATICALLY DENIED AT THE DISCRETION OF THE BUILDING/PLANNING DEPARTMENT, WE MAY REQUIRE ADDITIONAL INFORMATION IN ORDER TO APPROVE THIS PERMIT.**

*I hereby certify that I am the Owner of record of the named property, or that the owner of record authorizes the proposed work and that I have been authorized by the owner to make this application as his/her authorized agent. I agree to conform to all applicable laws of this jurisdiction. In addition, if a permit for work described in this application is issued, I certify that the Code Official's authorized representative shall have the authority to enter all areas covered by this permit at any reasonable hour to enforce the provisions of the codes applicable to this permit.*

Signature of applicant:	Date: <u>12-27-04</u>
-------------------------	-----------------------

**This is NOT a permit, you may not commence ANY work until the permit is issued.  
If you are in a Historic District you may be subject to additional permitting and fees with the  
Planning Department on the 4<sup>th</sup> floor of City Hall**

R B Allen 12-22-04 1-603-964-8140  
 64 Chestnut Street Shelter  
 EST2 Fire Alarm System

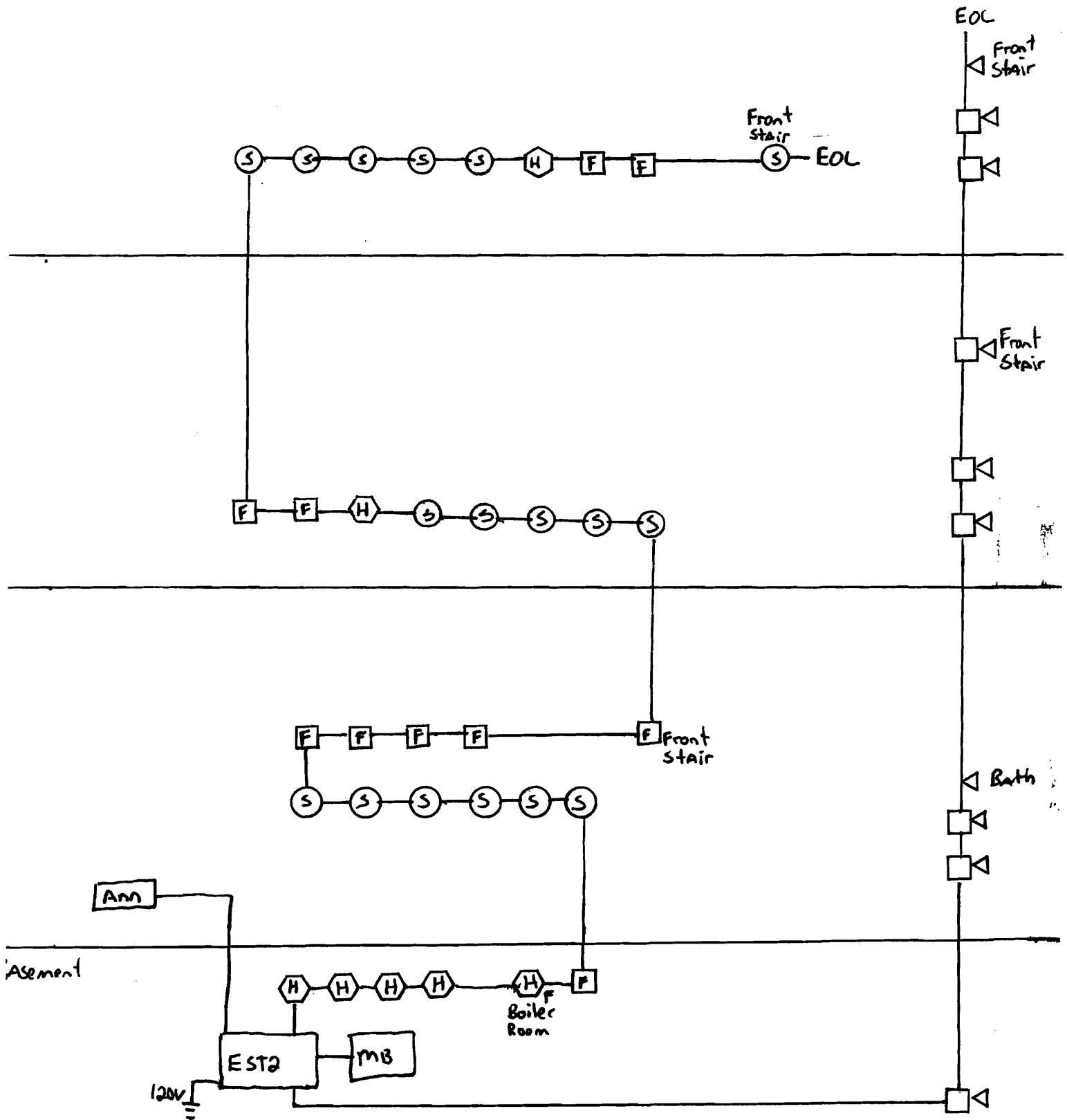

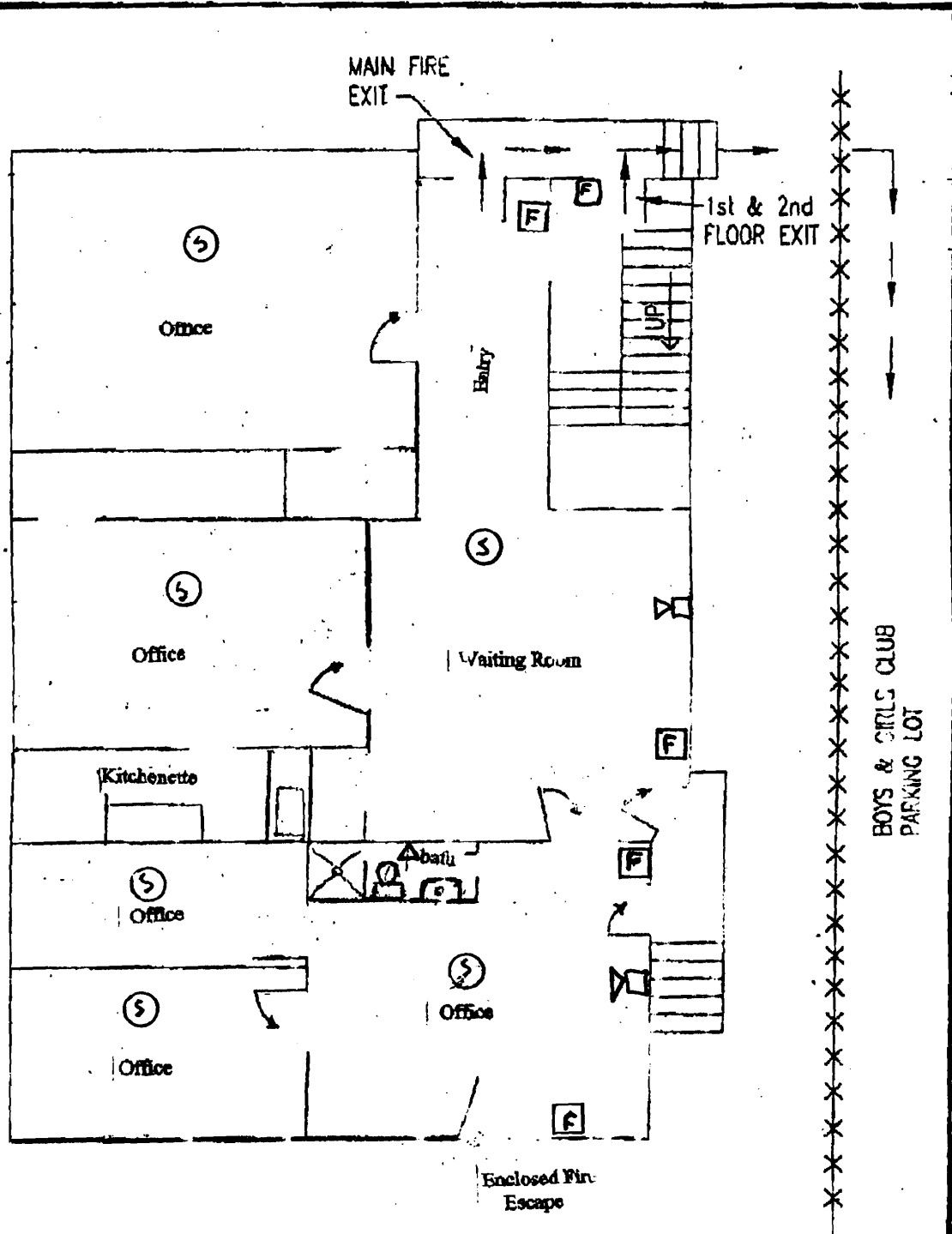

1ST FLOOR LAYOUT

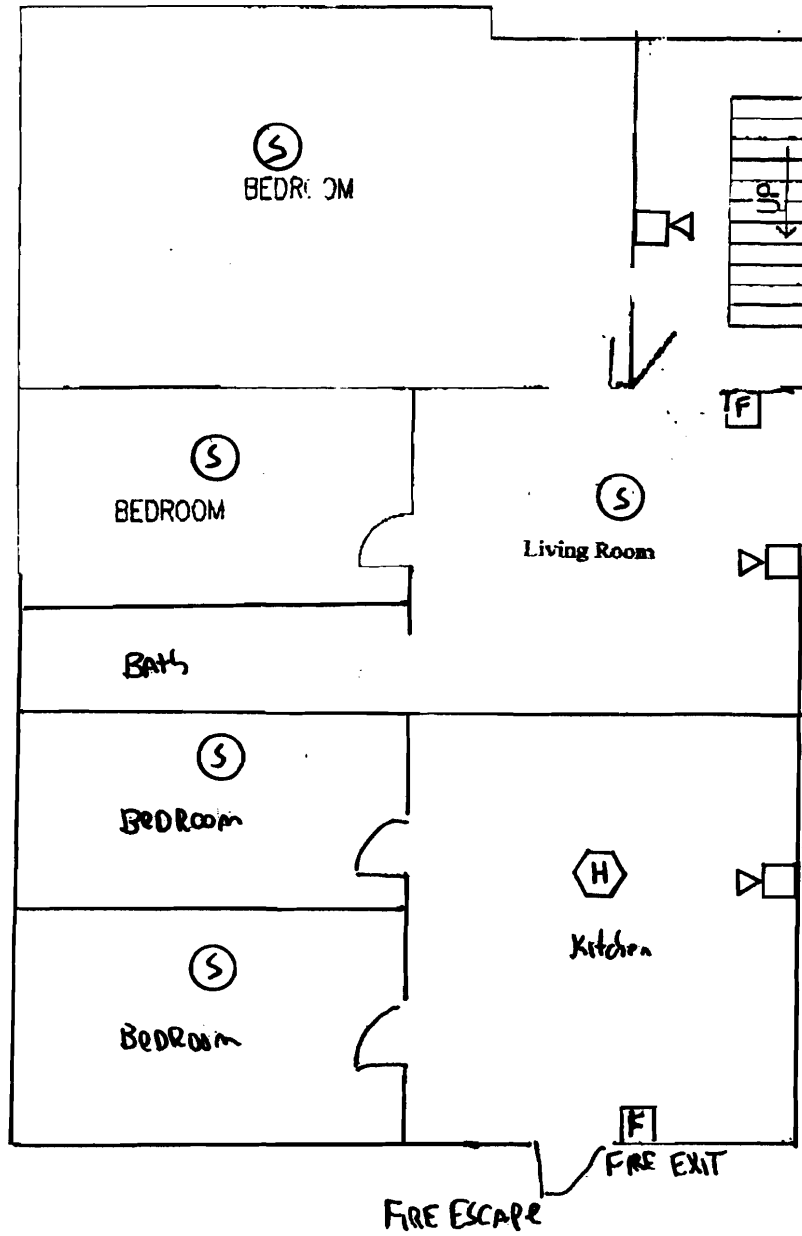

2ND Floor Layout

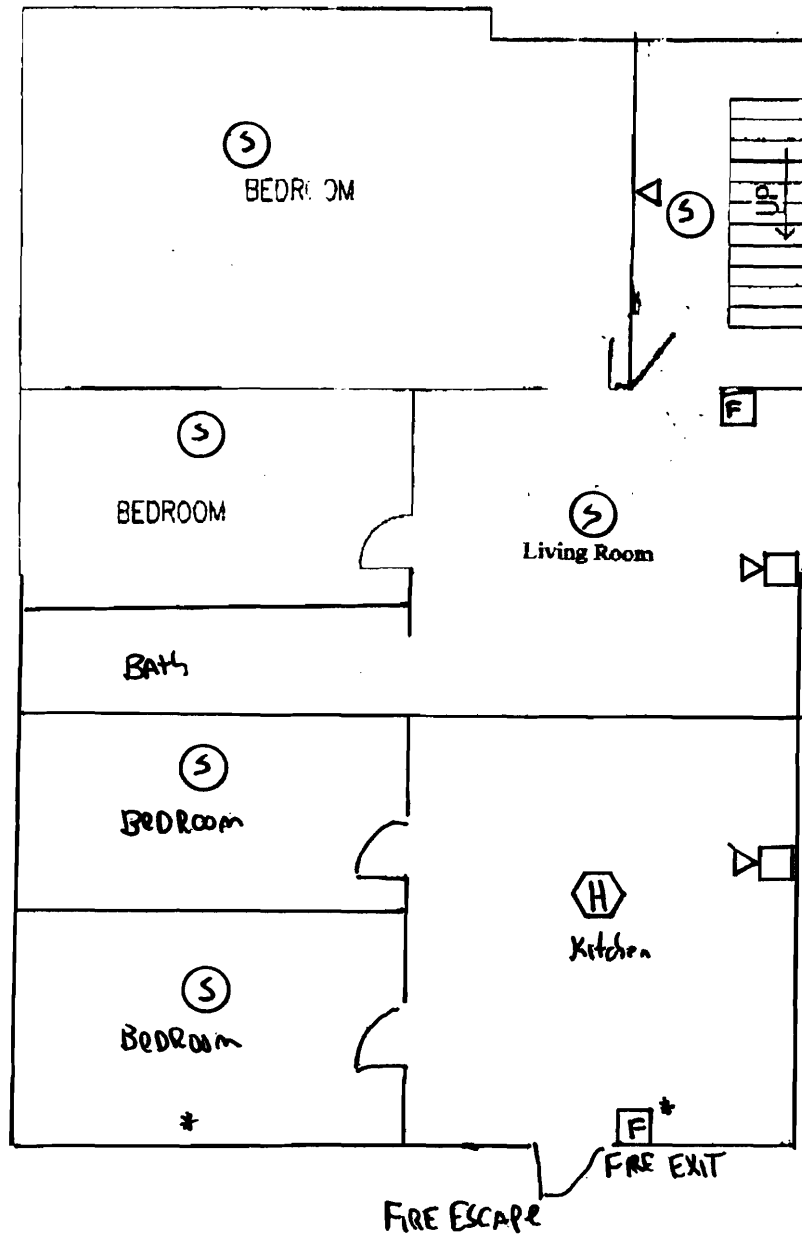

3rd FLOOR LAYOUT

\* Rear Pull shall be installed to suit Fire Exit



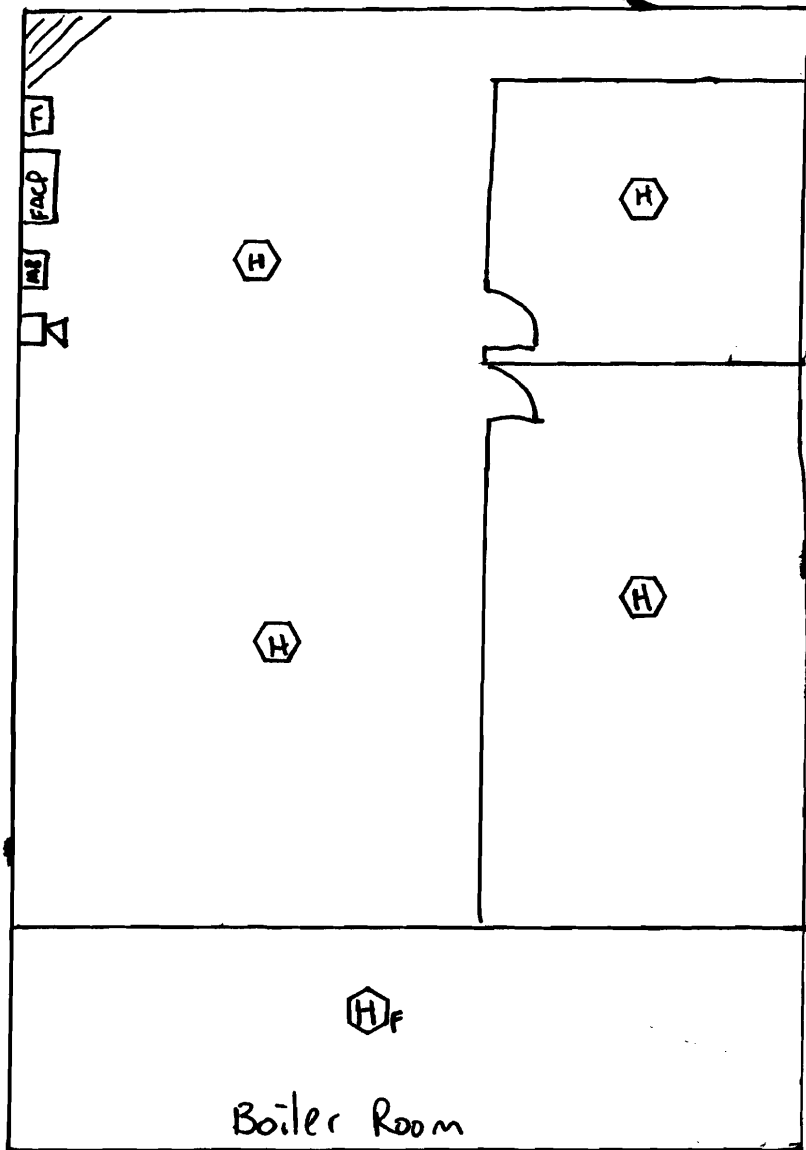

# ELECTRICAL PERMIT

## City of Portland, Me.



To the Chief Electrical Inspector, Portland Maine:  
 The undersigned hereby applies for a permit to make electrical installations  
 in accordance with the laws of Maine, the City of Portland Electrical Ordinance,  
 National Electrical Code and the following specifications:

Date 12/21/04  
 Permit # 045392  
 CBL# 26 C 005

LOCATION: 54 Chestnut Street METER MAKE & # \_\_\_\_\_  
 CMP ACCOUNT # \_\_\_\_\_ OWNER City of Portland  
 TENANT Chestnut Street Family Shelter PHONE # \_\_\_\_\_

**TOTAL EACH FEE**

OUTLETS	Receptacles	Switches	Smoke Detector	TOTAL EACH FEE	
				.20	
FIXTURES	Incandescent	Fluorescent	Strips	.20	
SERVICES	Overhead	Underground	TTL AMPS <800	15.00	
	Overhead	Underground	>800	25.00	
Temporary Service	Overhead	Underground	TTL AMPS	25.00	
				25.00	
METERS	(number of)			1.00	
MOTORS	(number of)			2.00	
RESID/COM	Electric units			1.00	
HEATING	oil/gas units	Interior	Exterior	5.00	
APPLIANCES	Ranges	Cook Tops	Wall Ovens	2.00	
	Insta-Hot	Water heaters	Fans	2.00	
	Dryers	Disposals	Dishwasher	2.00	
	Compactors	Spa	Washing Machine	2.00	
	Others (denote)			2.00	
	MISC. (number of)	Air Cond/win			3.00
		Air Cond/cent		Pools	10.00
		HVAC	EMS	Thermostat	5.00
	Signs			10.00	
	Alarms/res			5.00	
	Alarms/com			15.00	
	Heavy Duty(CRKT)			2.00	
	Circus/Carnv			25.00	
	Alterations			5.00	
	Fire Repairs			15.00	
	E Lights			1.00	
	E Generators			20.00	
PANELS	Service	Remote	Main	4.00	
TRANSFORMER	0-25 Kva			5.00	
	25-200 Kva			8.00	
	Over 200 Kva			10.00	
			TOTAL AMOUNT DUE		
			MINIMUM FEE/COMMERCIAL	45.00	
			MINIMUM FEE	35.00	

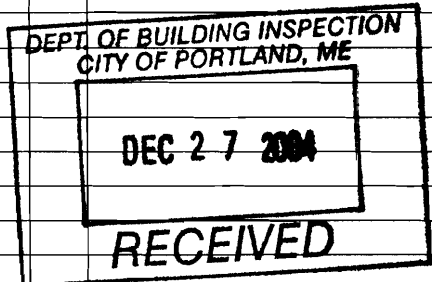

CONTRACTORS NAME Jeffrey B. Sugden MASTER LIC. # MS 6000 4032  
 ADDRESS 595 Neck Rd China Me 04101 LIMITED LIC. # \_\_\_\_\_  
 TELEPHONE 968-3279

SIGNATURE OF CONTRACTOR Jeffrey B. Sugden OK #976



# CITY OF PORTLAND, MAINE

## Department of Building Inspections

12 9 2009

Received from Henry ...

Location of Work 24 ...

Cost of Construction \$ \_\_\_\_\_

Permit Fee \$ 165.00

Building (IL)  Plumbing (I5)  (2)  Site Plan (U2) \_\_\_\_\_

Other See ...

CB

Chec

*OWES  
\$ 165.00  
well Drilling  
wed 12/29*

ected \$ 165.00

### PERMIT

upon the  
be grante  
granted the  
receipt less

is actually posted  
e that permit will  
ermit cannot be  
upon return of the  
greater.

WHITE - Applica. Copy  
YELLOW - Office Copy  
PINK - Permit Copy