

FIRST FLOOR	DOOR SCHEDULE										
	DOOR NUMBER	LOCATION	DOOR SIZE	THICK	MATERIAL	TYPE	FRAME MATERIAL	FRAME TYPE	HARDWARE	ACCESSORIES	NOTES
100	FRONT ENTRANCE	3'-0"x6'-8"	1-3/4"	MTL	A	MTL	1	T - C - H - KP - L3 - WS - DB			INSUL
101	MECHANICAL ROOM	3'-0"x6'-8"	1-3/4"	MTL	A	MTL	1	T - C - H - L4 - WS			INSUL

- ALL HARDWARE TO BE LEVER TYPE U.N.O.
- ALL KEYING TO BE COORDINATED W/ OWNER PRIOR TO ORDERING HARDWARE ITEMS.

DOOR HARDWARE SCHEDULE

- C - CLOSER LCN ADA COMPLIANT
 DS - DOOR STOP: GLYNN-JOHNSON FLOOR MOUNTED TYPE FB 19
 H - HINGES, 1 1/2" PAIR, 4 1/2"x4 1/2", S.S. BALL BEARING NON-REMOVABLE PINS ON EXTERIOR, FULL MORTISE
 KP - KICK PLATE: HAGAR, 14" HIGH, SS FINISH
 L1 - LOCKSET: STORAGE FUNCTION, CYLINDER LOCK WITH LEVER HANDLE
 L2 - LOCKSET: PRIVACY FUNCTION, CYLINDER LOCK WITH LEVER HANDLE
 L3 - LOCKSET: PASSAGE FUNCTION, CYLINDER LOCK WITH LEVER HANDLE
 L4 - LOCKSET: CLASSROOM FUNCTION, CYLINDER LOCK WITH LEVER HANDLE
 DB - DEADBOLT
 DP - DOOR PULL
 FB - FLUSH BOLT
 PP - PUSH PULL
 WS - WEATHER STRIP: ZERO TYPE 312 AT JAMBS & HEAD

ROOM #	LOCATION	FLOOR	BASE	WALLS				CEILING		REMARKS
				N	E	S	W	MAT.	HT.	
100	WOMENS	RBR	-	SSP	SSP	SSP	SSP	SSP	7'-6"	
101	MENS	RBR	-	SSP	SSP	SSP	SSP	SSP	7'-6"	
102	MECHANICAL	VCT	-	SSP	SSP	SSP	SSP	SSP	7'-6"	

FINISH SCHEDULE ABBREV.

- ACT - ACOUSTIC CEILING
 CONC. - EXPOSED SEALED CONCRETE
 EXP - EXPOSED
 GWB - GYPSUM BOARD
 MP - METAL LINER PANEL
 PCT - COMP. WOOD FLOORING
 RC - RESILIENT COVE
 RBR - RUBBER FLOOR
 SSP - STAINLESS-STEEL PANEL
 VCT - VINYL COMPOSITION TILE
 WC - WOOD COVE BASEBOARD

FINISH NOTES

- ALL GWB TO BE PAINTED 1 COAT PRIMER & 2 COATS FINISH.
- FINISH OF CLOSETS SHOULD MATCH FINISH OF ROOM THE CLOSET IS INSTALLED IN UNLESS SPECIFICALLY NOTED IN THE TABLE OTHERWISE.

FLOORING NOTE

ALL INTERIOR FLOOR FINISHES OTHER THAN CARPETING SHALL MEET FLAME RETARDANT REQUIREMENTS AS SPECIFIED UNDER NFPA 101-10.2, CLASS II RATING.

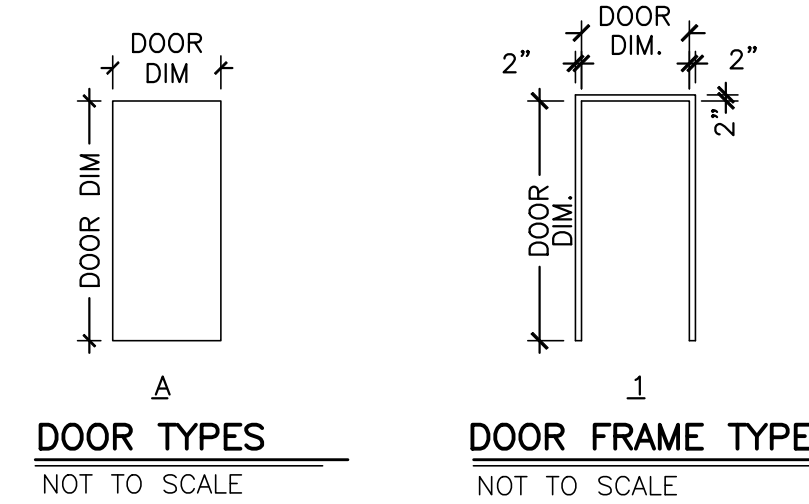

GENERAL NOTES

- CONTRACTOR TO VERIFY ALL DIMENSIONS AND CONDITIONS; REPORT ANY DISCREPANCIES TO ENGINEER BEFORE PROCEEDING WITH WORK.
- CONSTRUCTION SHALL FOLLOW INTERNATIONAL BUILDING CODE (2009 EDITION).
- STRUCTURAL SYSTEMS AND COMPONENTS DESIGN SHALL FOLLOW 2009 INTERNATIONAL BUILDING CODE.
- COORDINATE WITH OWNER FOR SIZE AND LOCATION OF OPENINGS IN STRUCTURE NOT SHOWN ON STRUCTURAL DRAWINGS.
- MANUFACTURER IS RESPONSIBLE FOR ADEQUATE BRACING OF STRUCTURAL MEMBERS, WALLS AND NON STRUCTURAL ITEMS DURING CONSTRUCTION AND TRANSPORTATION.
- ALL STRUCTURAL COMPONENTS AND SYSTEMS SHALL BE DESIGNED FOR SELF WEIGHT, SUPERIMPOSED DEAD LOADS, CONCENTRATED LOADS SHOWN ON PLANS, AND THE LIVE LOADS.
- ALL REFERENCED STANDARDS REFER TO LATEST EDITION.
- GENERAL CONTRACTOR TO COORDINATE ALL FLOOR PENETRATIONS WITH APPROPRIATE TRADES.
- DESIGN OF ELECTRICAL WILL BE DONE BY OTHERS FOLLOWING PAN 70 AND STATE OF MAINE REQUIREMENTS.
- ALL WELDING SHALL BE IN ACCORDANCE W/ THE LATEST EDITION OF THE STRUCTURAL WELDING CODE.
- DESIGN FOR THIS BATHROOM DOES NOT MEET 2010 ADA STANDARDS REQUIREMENTS AT OWNERS REQUEST.

DESIGN LOADS

- ROOF**
 DEAD LOAD: PER COMPONENTS USED: 8.5 PSF
 COLLATERAL LOAD (MECH/ELEC): 2 PSF
- SNOW LOAD:** (BASED ON ASCE 7-05)
 GROUND SNOW LOAD (Pg): 60 PSF
 EXPOSURE FACTOR (Ce): 1.0
 SNOW LOAD IMPORTANCE FACTOR (I): 1.0
 ROOF THERMAL FACTOR - (Ct): 1.0
- SEISMIC DATA:** (BASED ON ASCE 7-05)
 SEISMIC LOADS WERE CHECKED AND DO NOT CONTROL.
- WIND LOAD:** (BASED ON ASCE 7-05)
 BASIC WIND SPEED: 100 MPH
 IMPORTANCE FACTOR (I): 1.0
 EXPOSURE: B

NO.	DATE	REVISIONS	DESCRIPTION

PROJECT NAME: OXFORD ST. SHELTER BATHROOM
 PORTLAND MAINE
 SHEET NAME: FIRST FLOOR PLAN

DESIGNED: KGE	PROJECT NO: 17289
DRAWN: DFW	DRAWING NO: 17289A
CHECKED: KGE	FIELDBOOK:
APPROVED: KGE	SCALE:
PLAN DATE: NOV. 21, 2017	DATE ISSUED: NOV. 21, 2017
CLIENT: GUNSPACE SOLUTIONS 55 BAKER BLVD BREWER, MAINE 04412	

Plymouth Engineering, Inc.
 P.O. Box 46
 30 Lower Detroit Road
 Plymouth, Maine 04989
 Tel: (207) 257-2071 Fax: (207) 257-2130
 info@plymouthengineering.com
 www.plymouthengineering.com

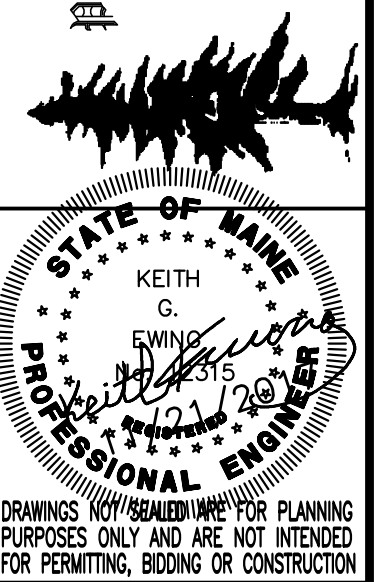

DRAWINGS NOT BE USED FOR PLANNING PURPOSES ONLY AND ARE NOT INTENDED FOR PERMITTING, BIDDING OR CONSTRUCTION