

2 MEZZANINE (LEVEL BETWEEN 2ND AND 3RD FLOORS) PLAN  
 1/8" = 1'-0"

- PLAN NOTES**
- 1) PREPARE ALL WALL AND FLOOR SURFACES TO RECEIVE NEW FINISHES PER FINISH MANUFACTURERS INSTALLATION INSTRUCTIONS. REMOVE AND REPLACE ALL DAMAGED FLOOR SHEATHING FOUND UPON REMOVAL OF EXISTING FLOORING
  - 2) FIRE STOPPING SHALL CONSIST OF UL LISTED ASSEMBLIES AND BE INSTALLED PER CODE
  - 3) ALL FLOORS TO BE LEVELED WITH A FULL COATING OF FLOOR LEVELER PRIOR TO INSTALLATION OF VCT OR LVT FINISHED FLOORING
  - 4) ALL CABINETS TO BE MID-GRADE LAB QUALITY CABINETS OF PLYWOOD CONSTRUCTION
  - 5) WHERE CABINETS AND COUNTERTOPS ARE SHOWN INCLUDE 12" DEEP WALL CABINETS ABOVE FOR FULL LENGTH OF CABINETS
  - 6) ALL COUNTERTOPS TO BE EPOXY LAB GRADE WITH 4" BACKSPASHES, UNLESS OTHERWISE NOTED
  - 7) ALL SINKS IN EPOXY COUNTERTOPS TO BE EPOXY SINKS UNDERMOUNTED
  - 8) PROVIDE BLOCKING IN WALLS AT ALL CABINETS, GRAB BARS, TOILET ACCESSORIES, WHITEBOARDS, PROJECTORS, ETC.
  - 9) PROVIDE 'VENETIAN' BLINDS AT ALL EXTERIOR WINDOWS
  - 10) AT SPRAY ROOM, SEAL AND CAULK ALL JOINTS IN DRYWALL, SEAL TO FLOOR AND FLOOR DECK ABOVE
  - 11) PROVIDE CORNER GUARDS AT ALL EXTERIOR WALL CORNERS FROM FLOOR TO 48" AFF

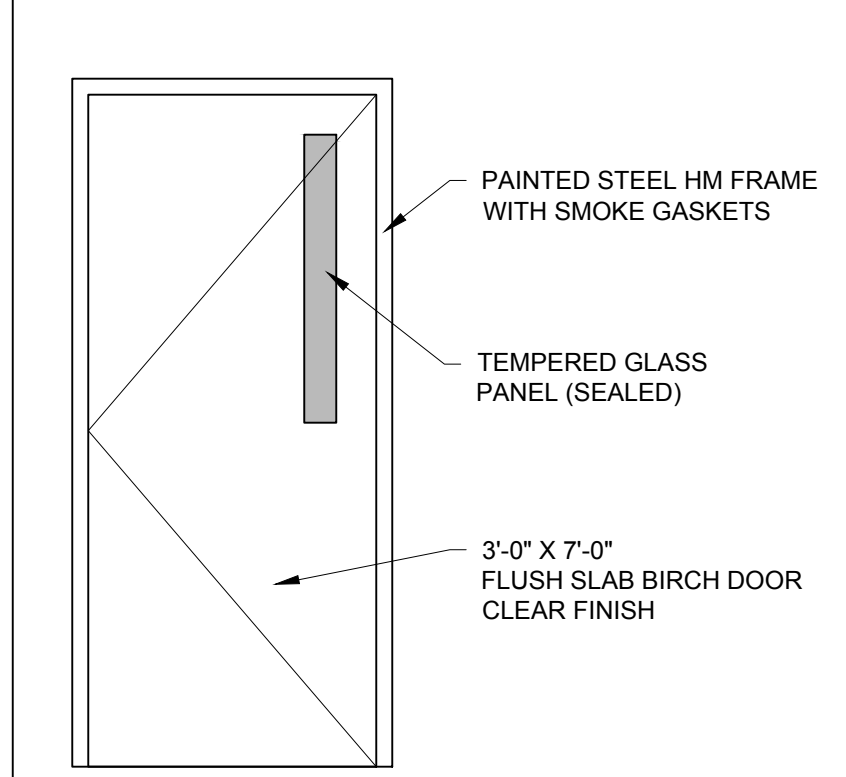

TYPICAL (NON FIRE RATED) DOOR DETAIL

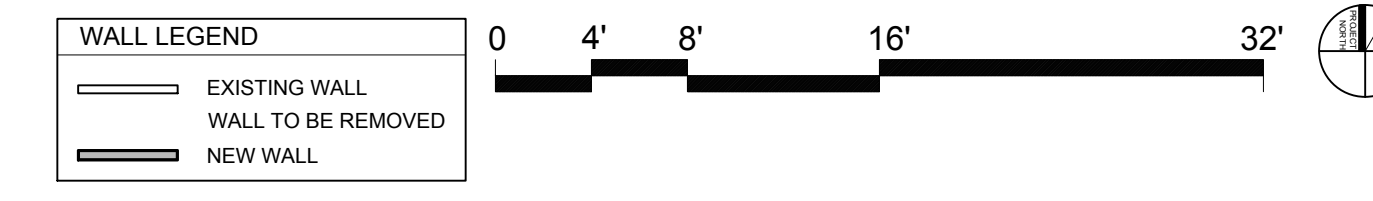

1 SECOND FLOOR PLAN  
 1/8" = 1'-0"