

ADA ACCESSIBLE CURB RAMP GENERAL NOTES

1. THERE SHALL BE A MINIMUM OF 12" AGGREGATE SUBBASE COURSE-GRAVEL UNDER THE 2" PAVEMENT ON SIDEWALK RAMP.
2. ALL ADA ACCESSIBLE CURB RAMP DETAILS SHALL BE PERMITTED THROUGH THE MAJORS STORE.

ADA ACCESSIBLE CURB RAMP GENERAL

NOTE:
CURB FINISHES FOR
FEDERATION RAMPS SHALL BE
6" MINIMUM
ALL ADA ACCESSIBLE CURB
RAMP DETAILS SHALL BE
PERMITTED THROUGH THE
MAJORS STORE

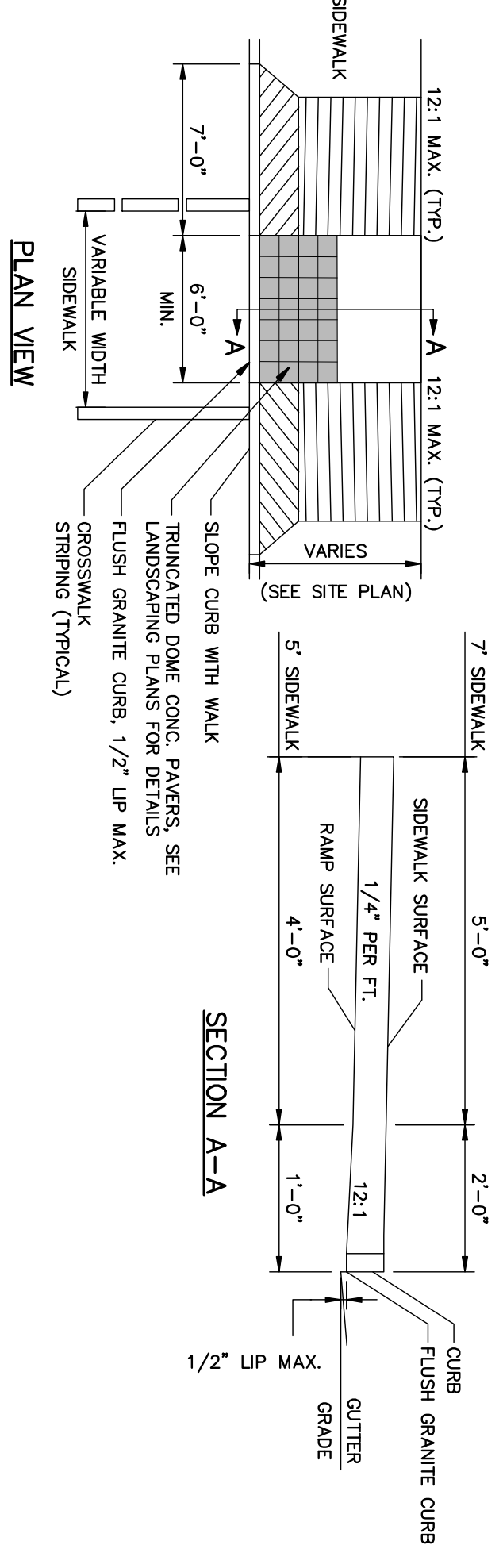
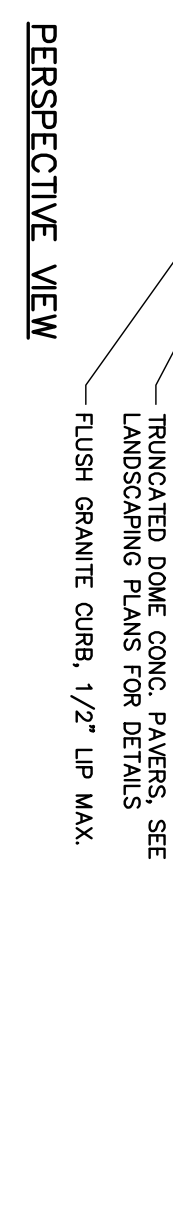
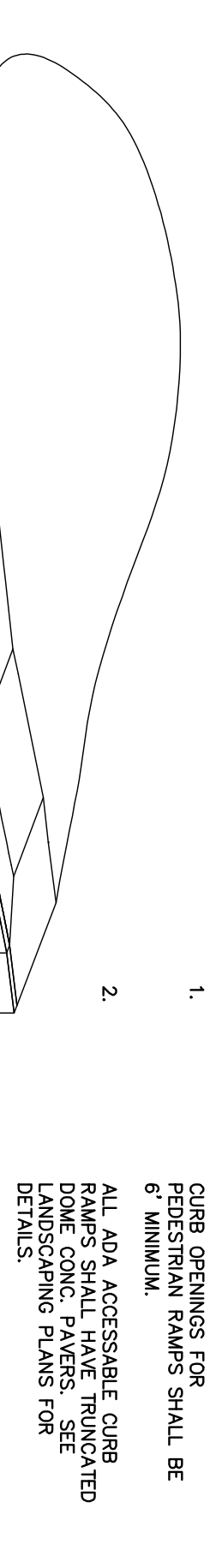

WALK THROUGH

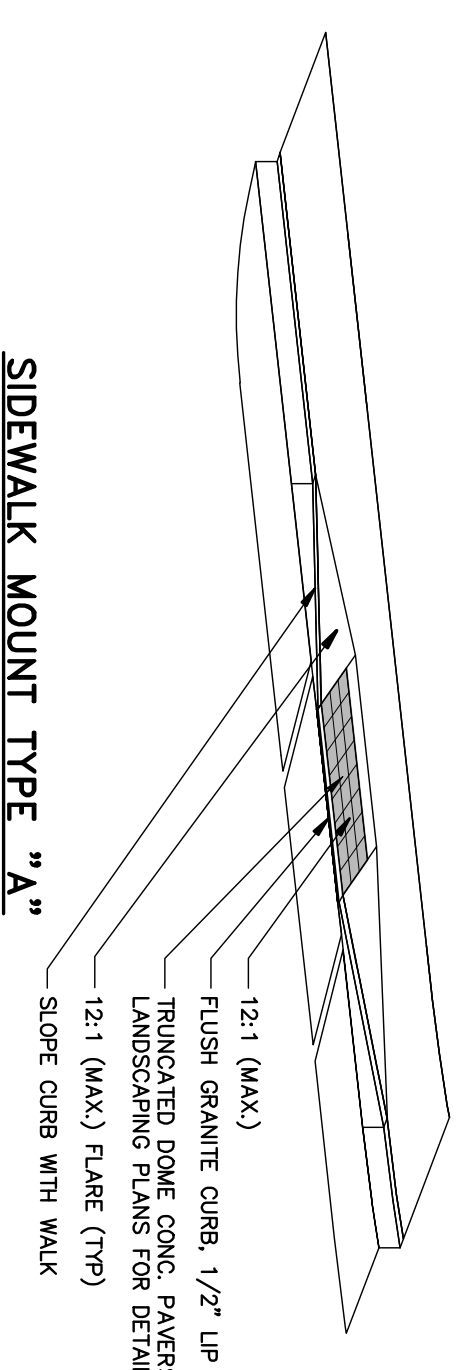

SIDEWALK MOUNT TYPE "A"

ADA ACCESSIBLE CURB RAMP

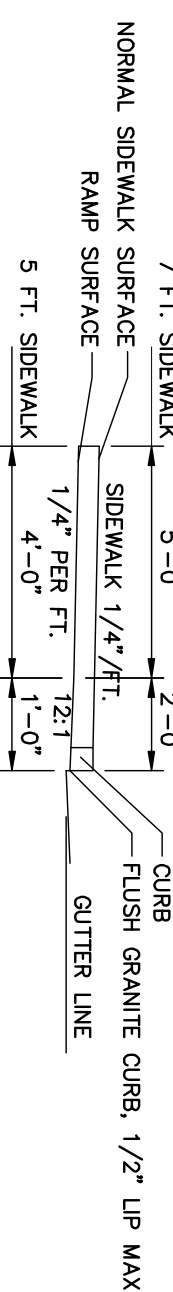
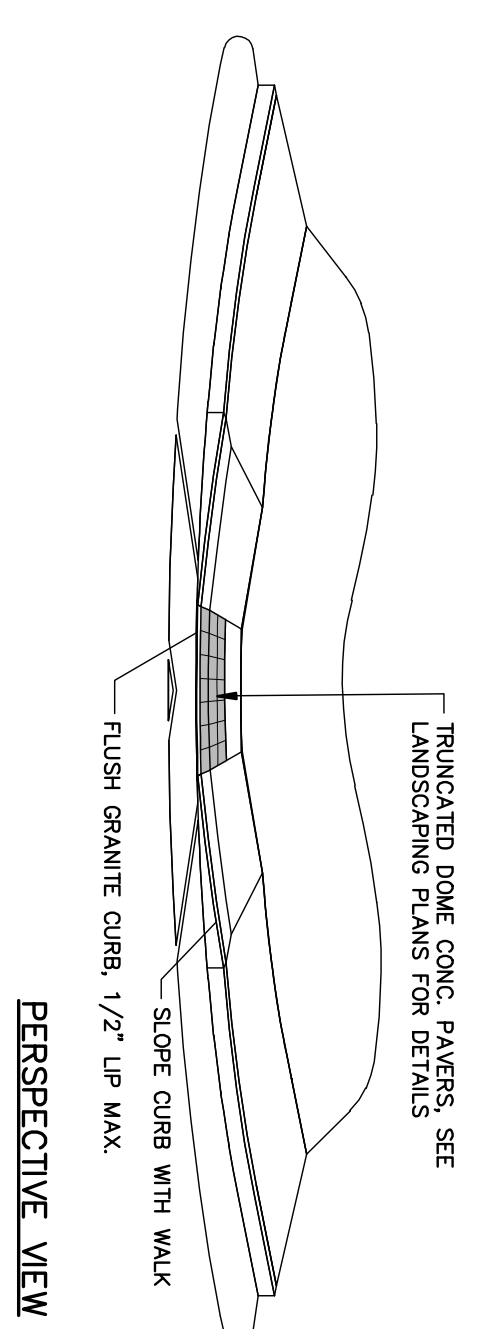

NOTE - RADIUS CURB
1. NO VERTICAL CURB ACCESS SHALL BE PERMITTED THROUGH THE MAJORS STORE.

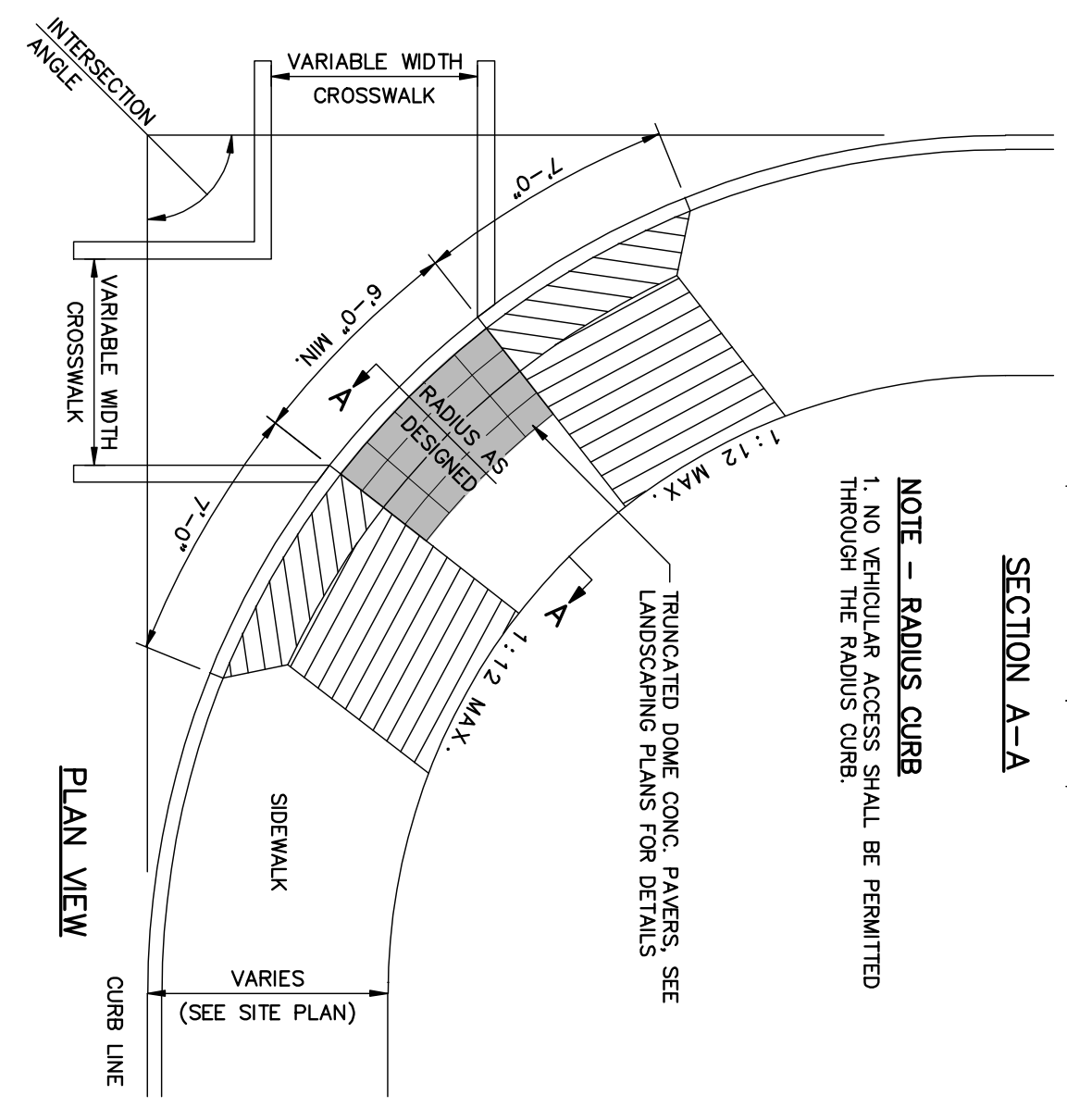

RADIUS CURB TYPE "B"

CURB TYPES 1 ON CURVES			
$\frac{1}{2}$	$\frac{1}{4}$	RADIUS OF CURVE	LENGTH
1	2	0' TO 60' INCL.	4' MIN.
2	3	OVER 60' TO 180'	4' TO 6'

NOTE: STONE IS CUT OR CAST STRAIGHT PIECES

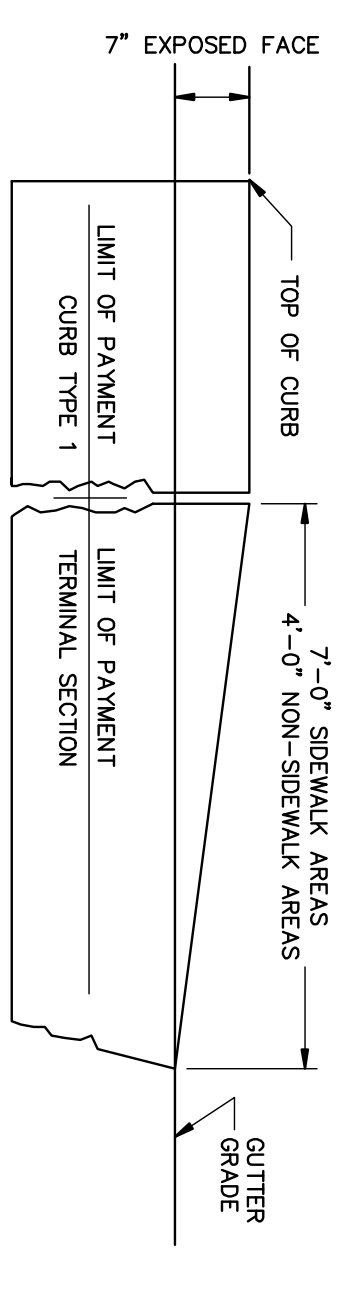

TERMINAL CURB SECTION

N.T.S.

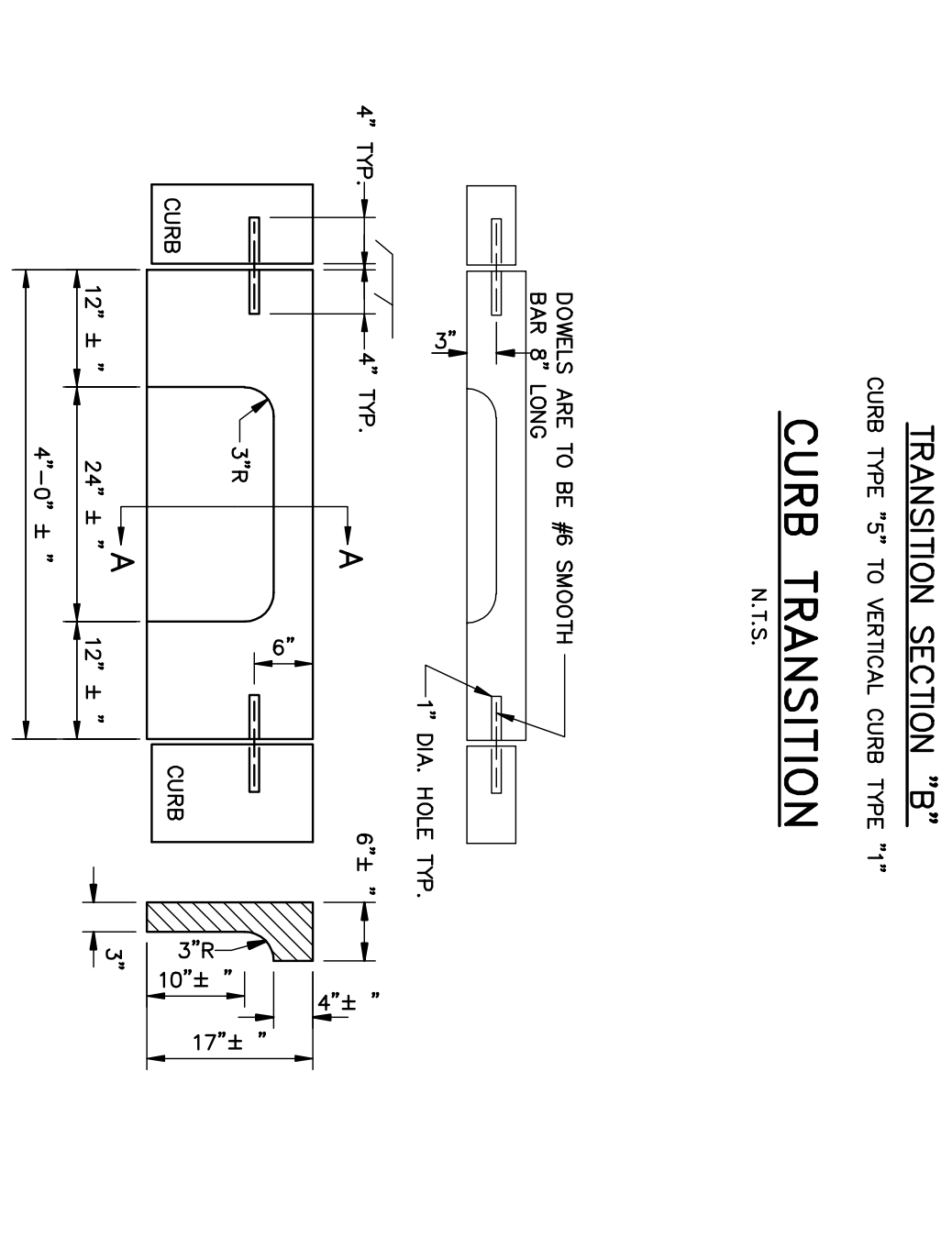

DECORATIVE CONCRETE PAVEMENT SECTION

N.T.S.

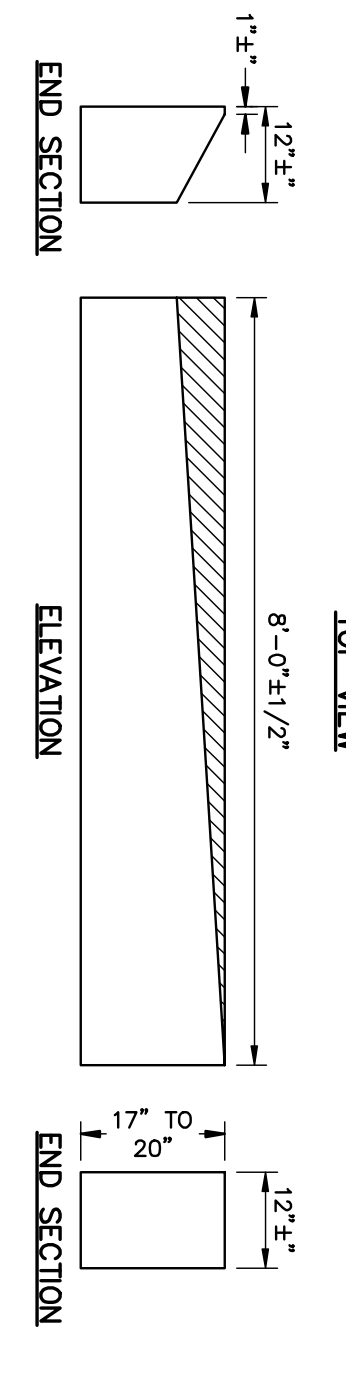

TRANSITION SECTION "B" CURB TRANSITION

N.T.S.

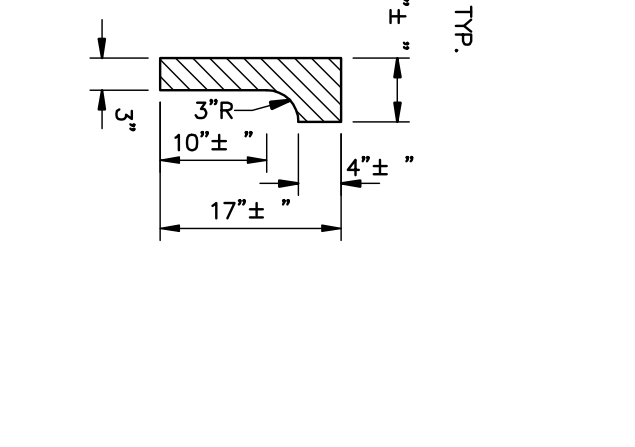

TYPE 1 GRANITE CURB INLET

N.T.S.

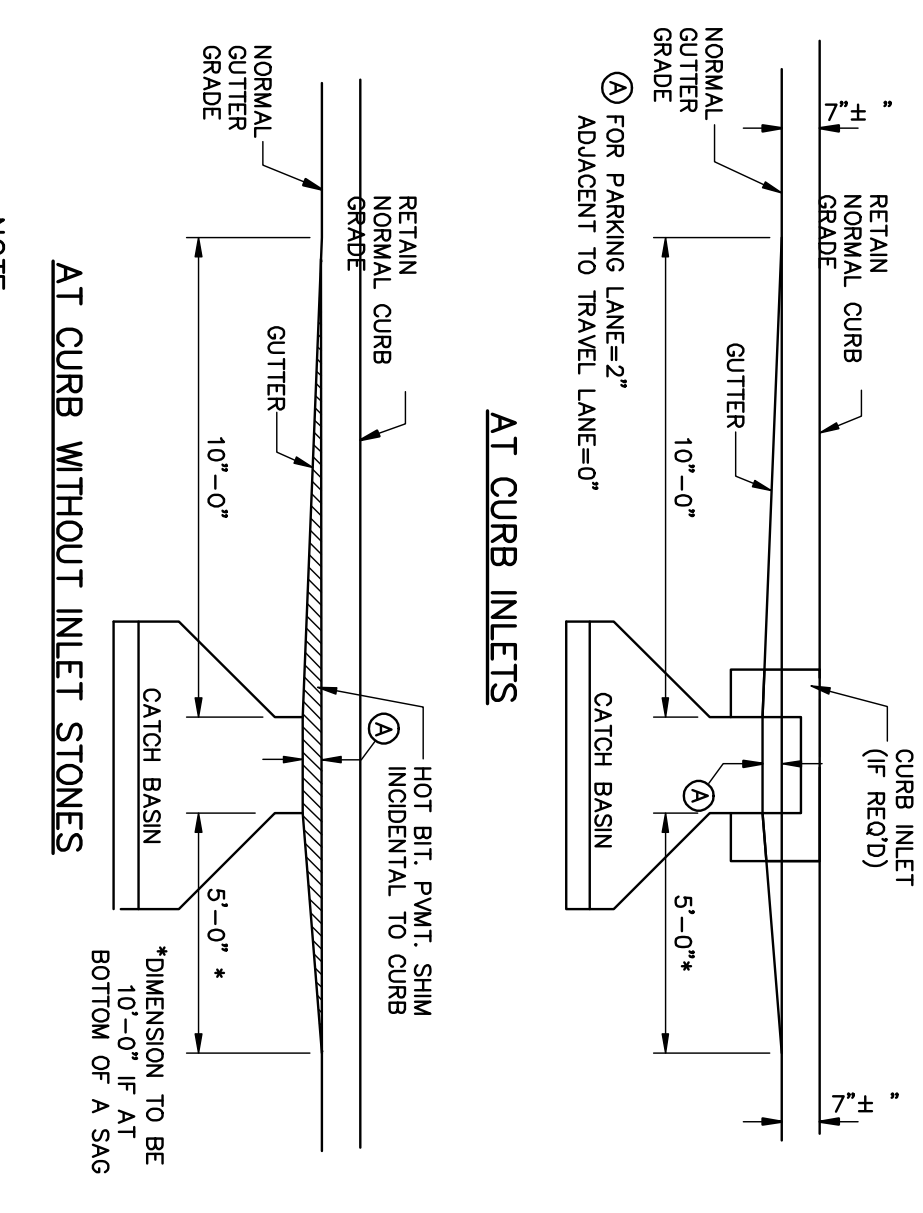

GUTTER GRADE TRANSITION AT CATCH BASIN

N.T.S.

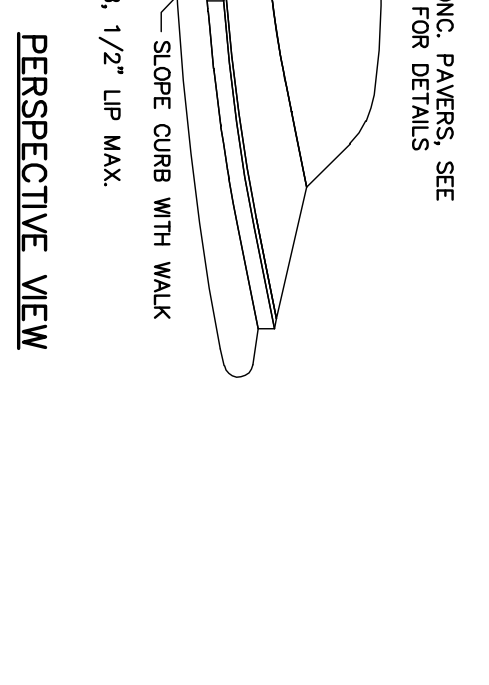

TYPICAL TRENCH REPAIR SECTION

N.T.S.

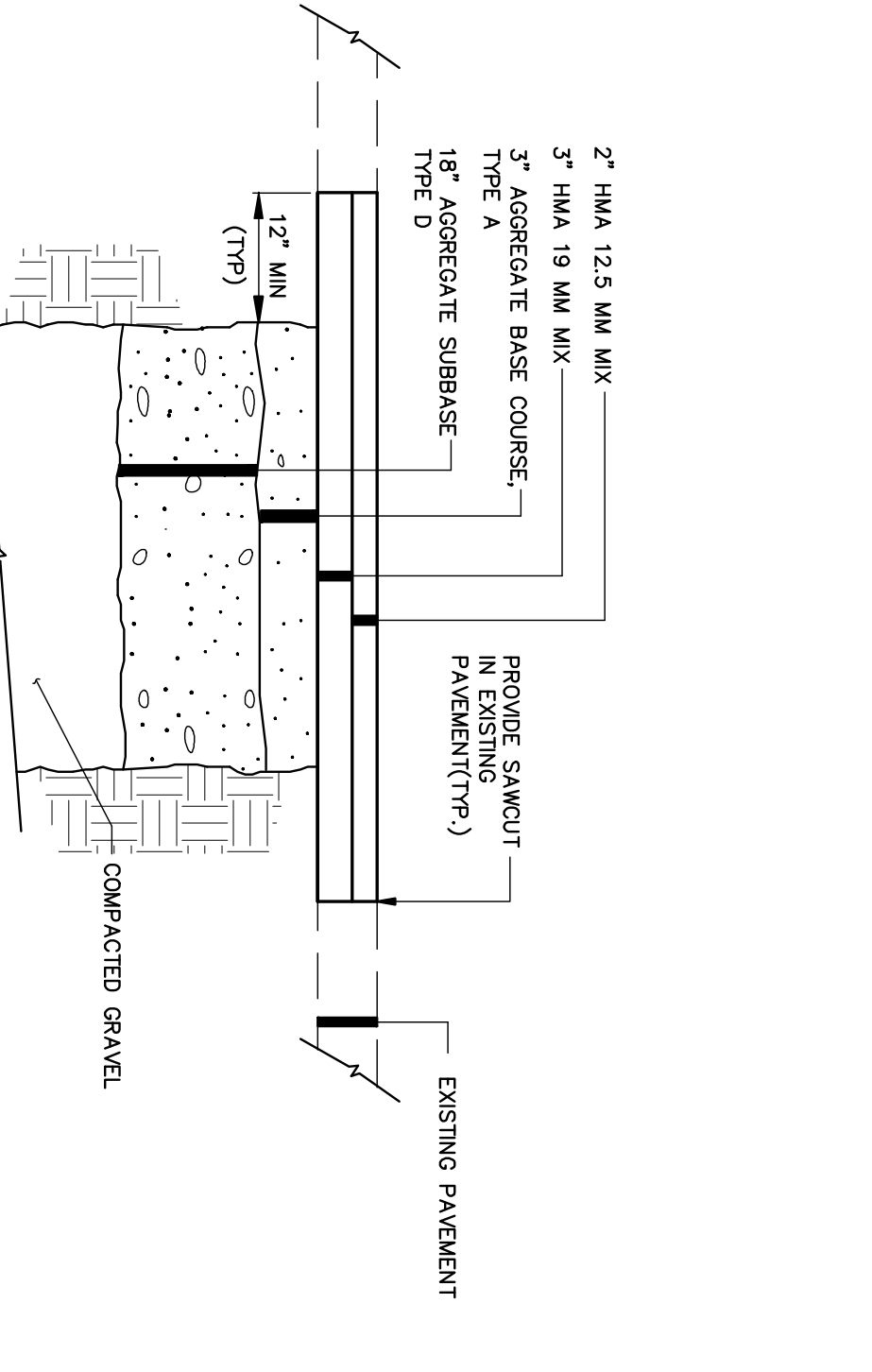

TYPICAL CURB INSTALLATION

N.T.S.

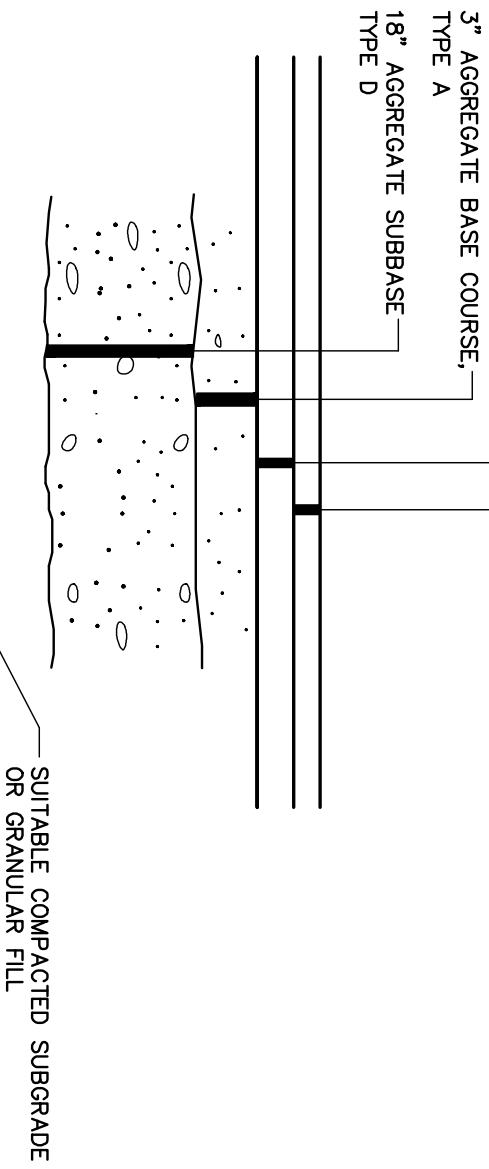

TYPICAL PAVEMENT SECTION

N.T.S.

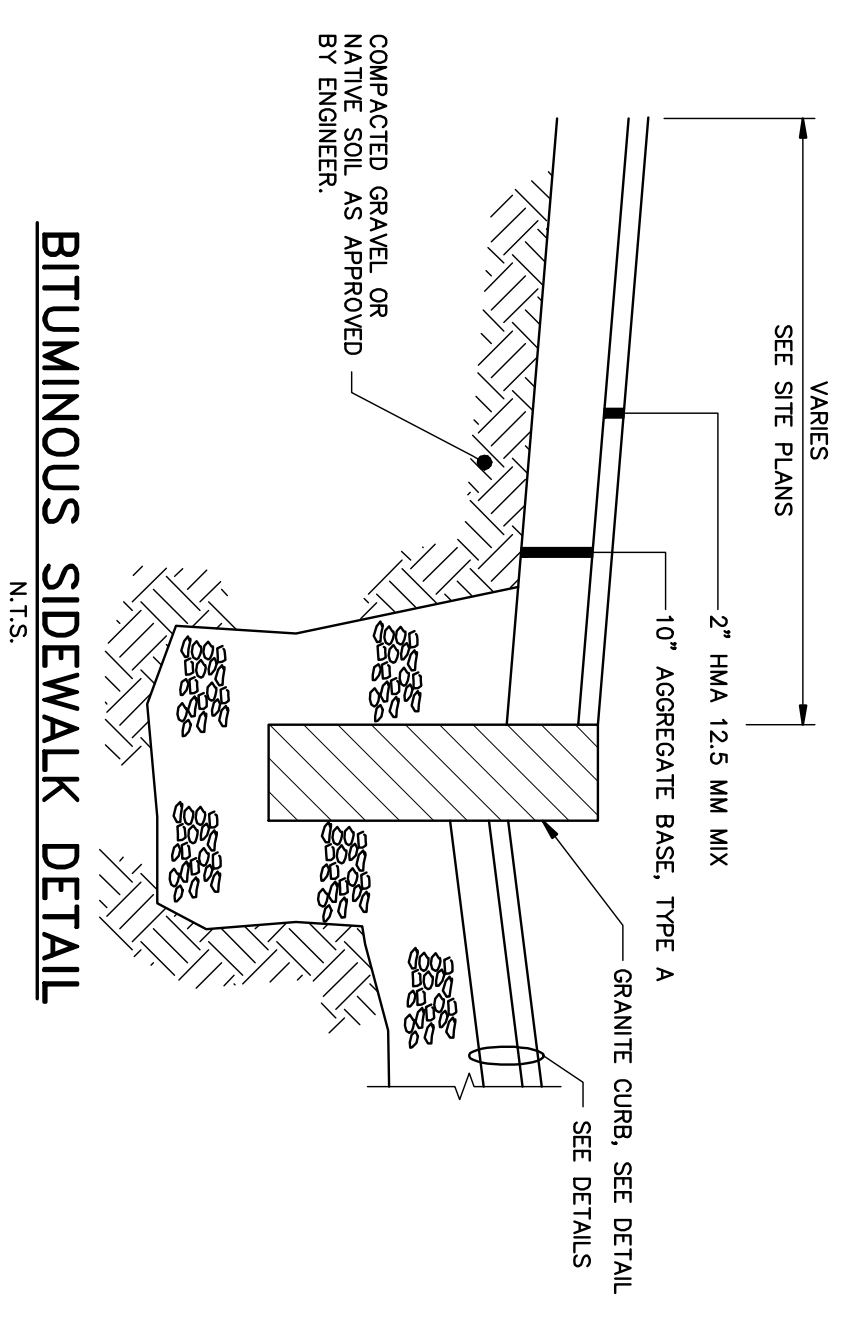

BITUMINOUS SIDEWALK DETAIL

N.T.S.

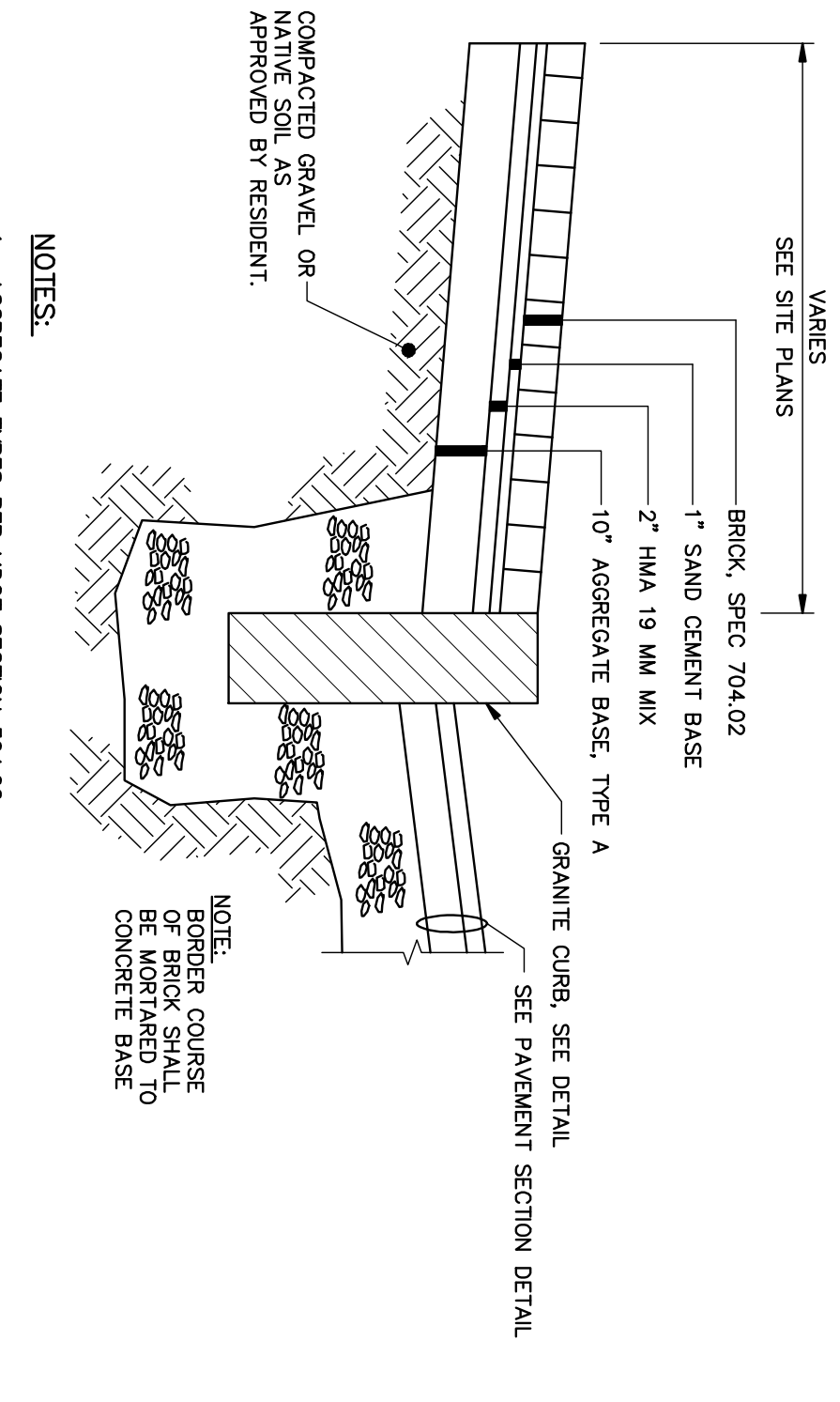

BRICK SIDEWALK DETAIL

N.T.S.

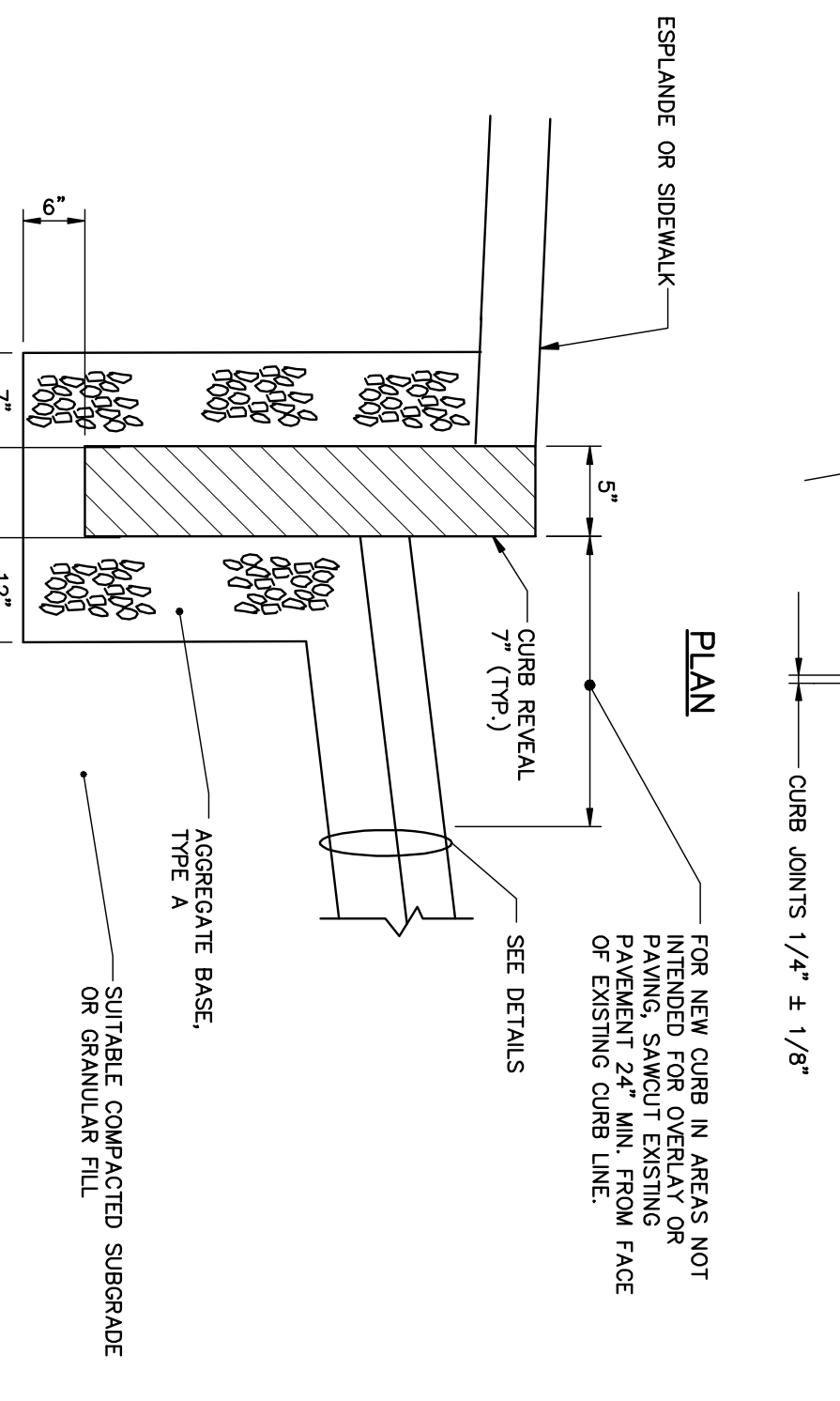

TYPICAL CURB BUTT JOINT DETAIL

N.T.S.