

3 REAR EGRESS STAIR AND RAILING
3/4" = 1'-0"

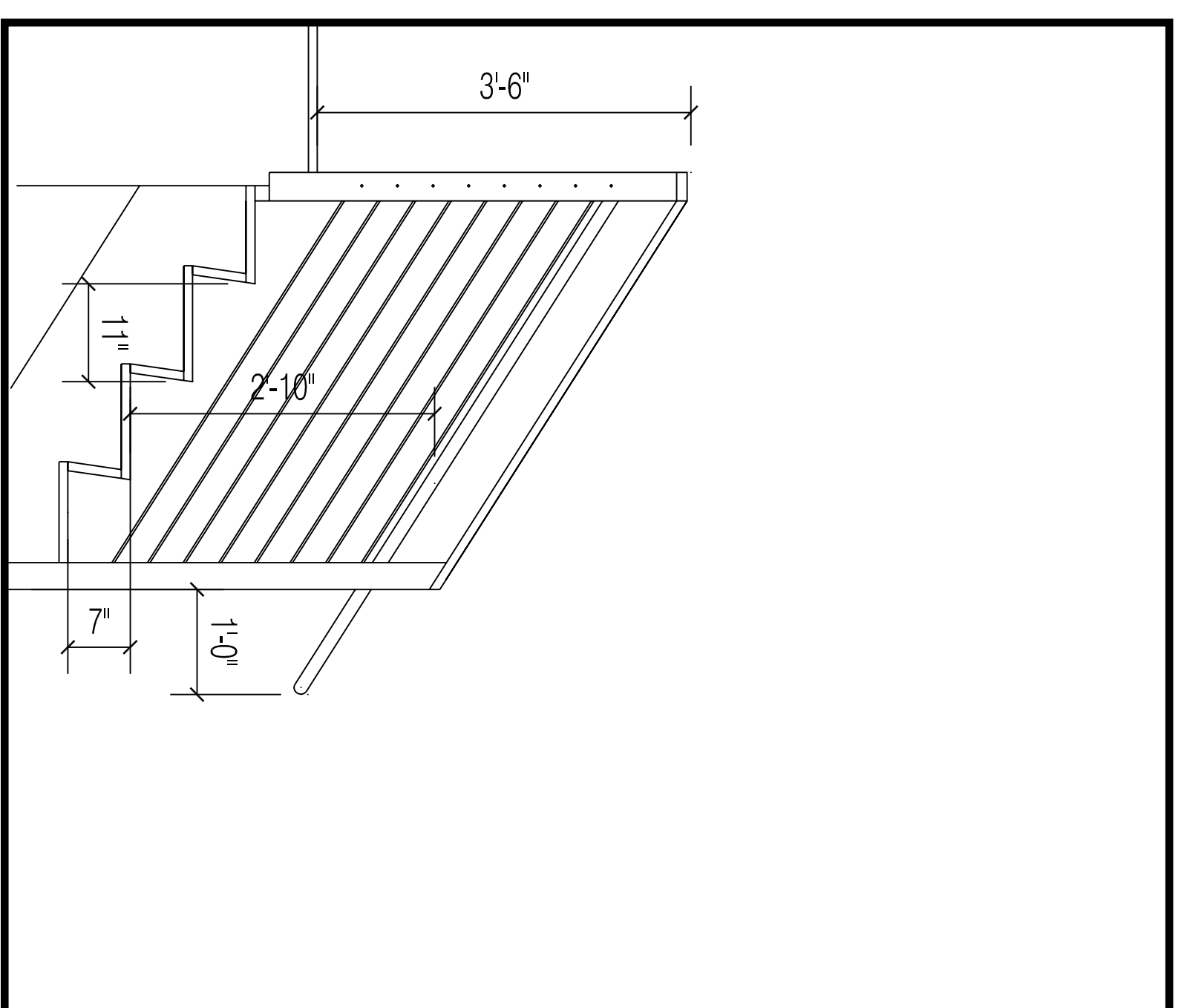

4 FRONT STAIR AND RAILING PROFILE
3/4" = 1'-0"

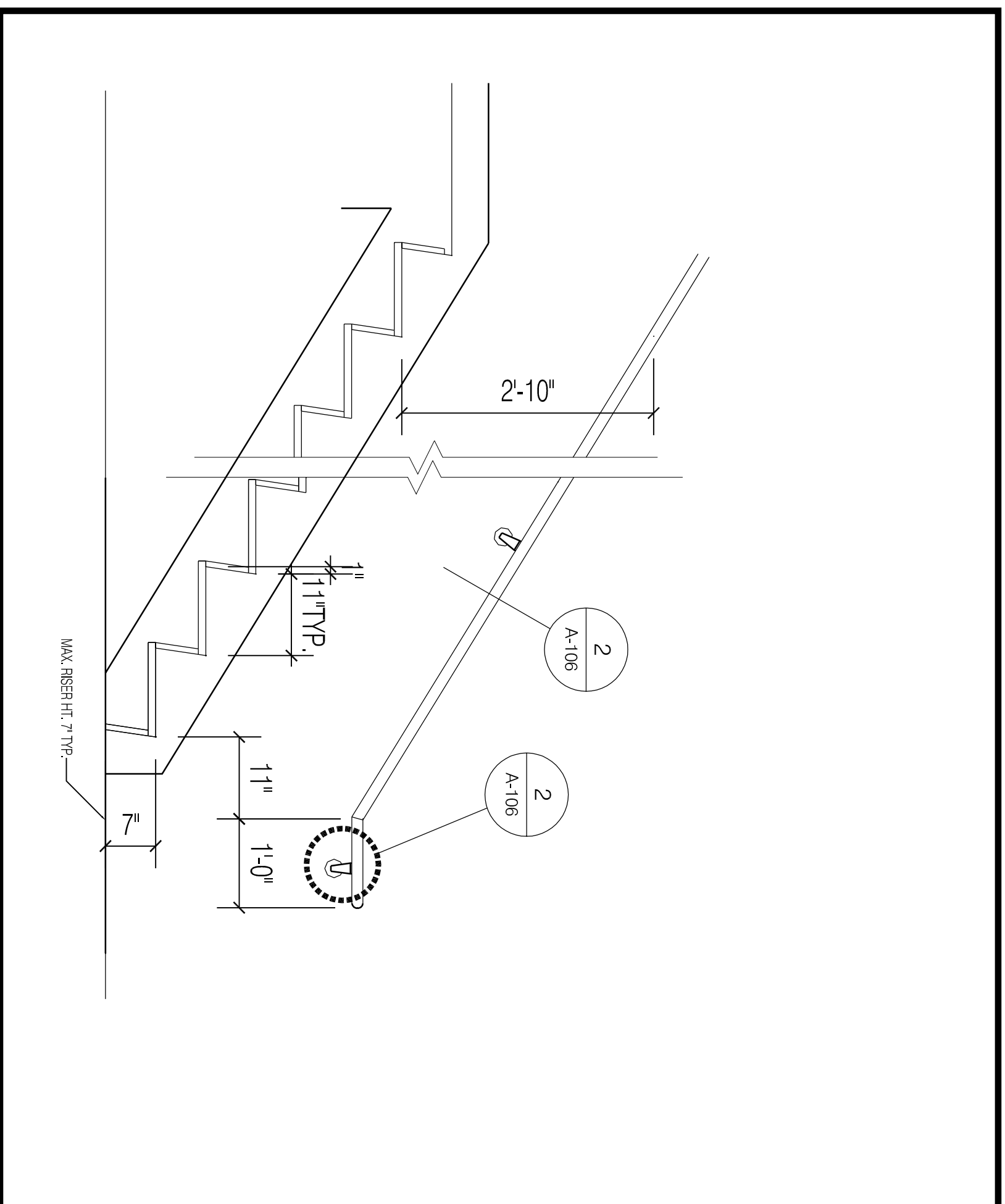

1 STAIR PROFILE
3/4" = 1'-0"

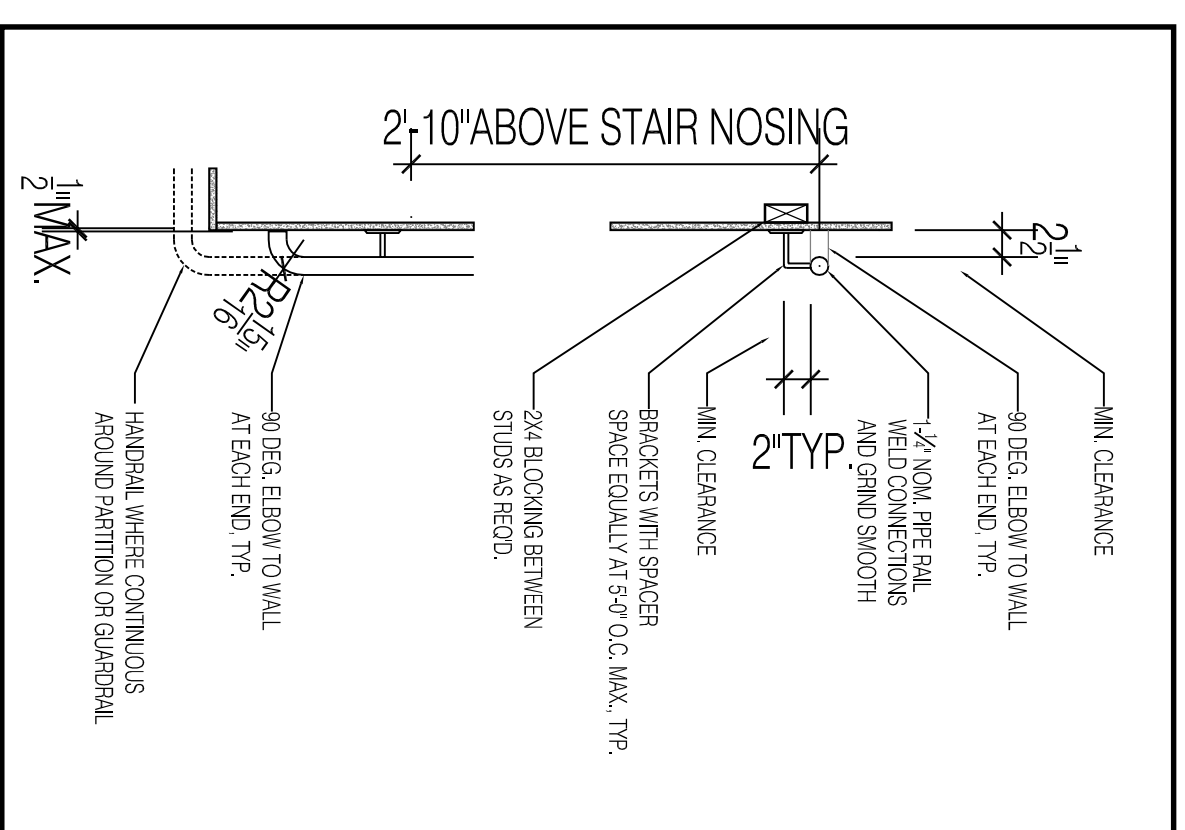

2 HANDRAIL DETAIL
3/4" = 1'-0"

NOTE:
1. MINIMUM CLEAR FINISHED WIDTH IS 4"
2. MAXIMUM RISER HT 7" TYP
3. MAXIMUM RAMP SLOPE IS 1/12

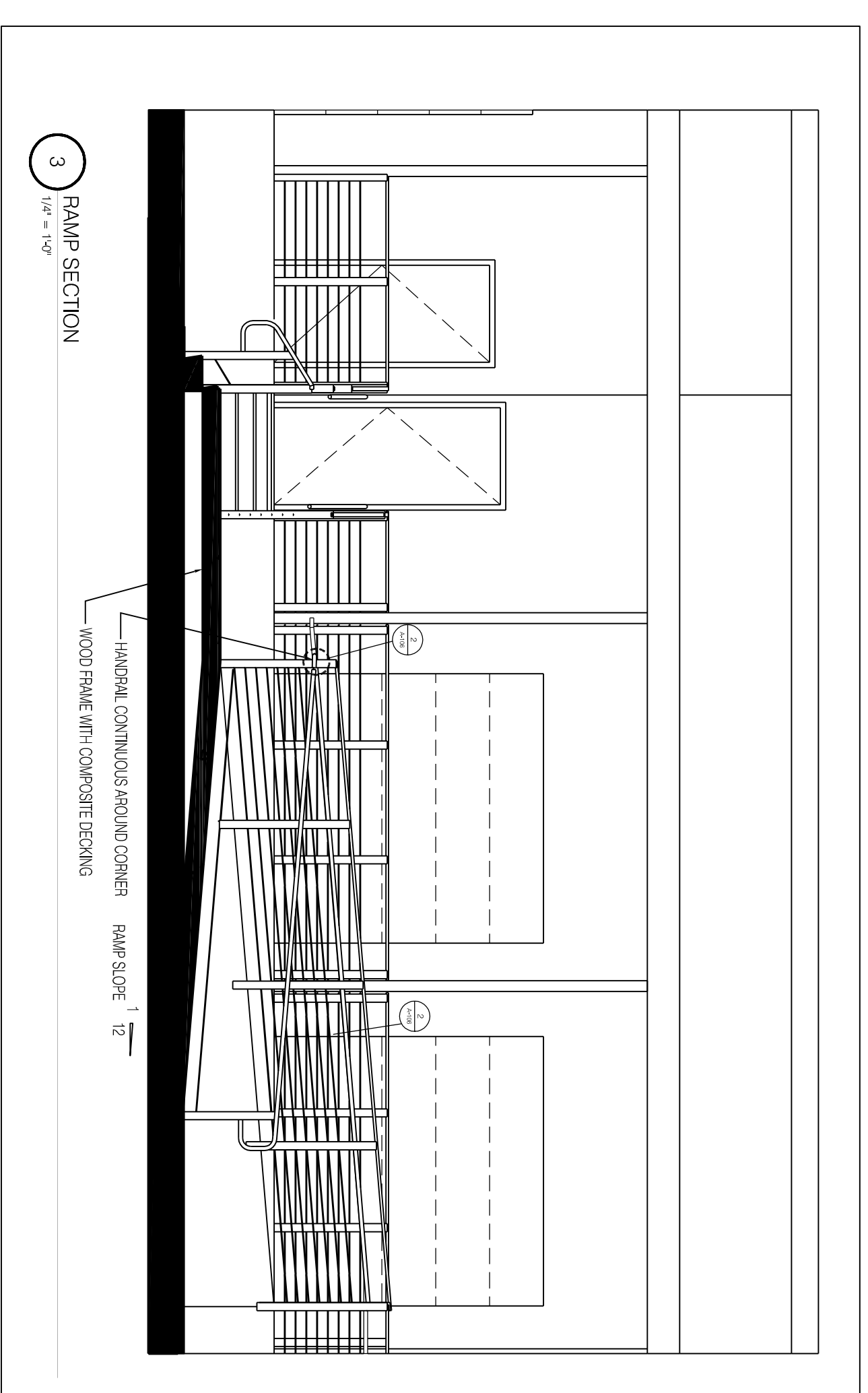
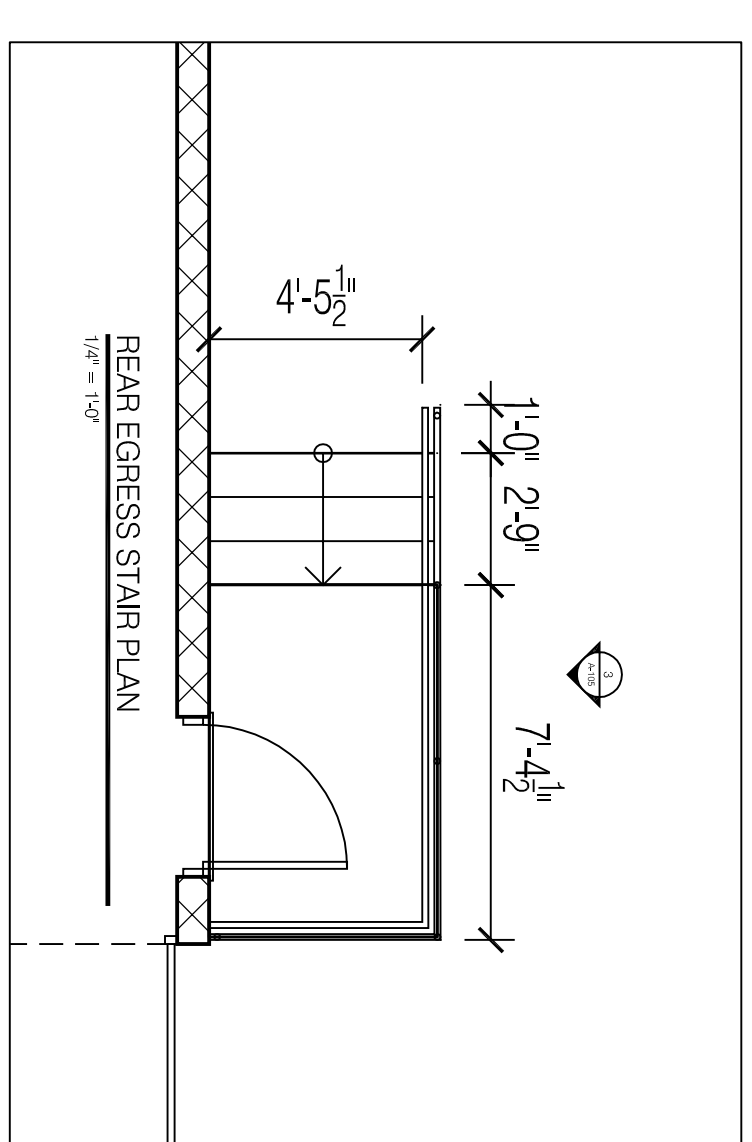

3 RAMP SECTION
1/2" = 1'-0"

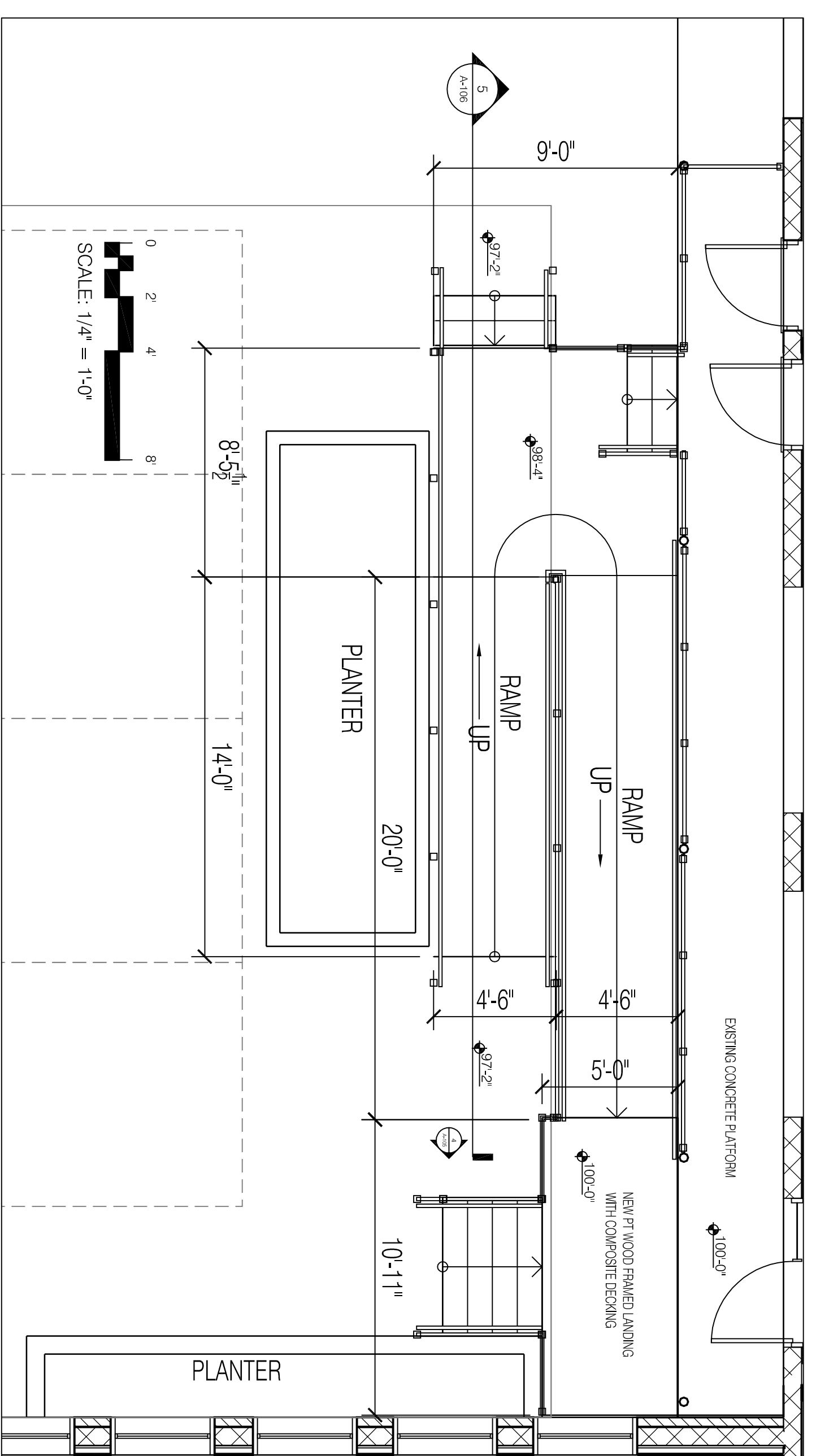

SCALE: 1/4" = 1'-0"

RAMP PLAN

DIAMOND ST. WAREHOUSE RENOVATION
1-11 DIAMOND ST, PORTLAND, ME
A.D. BEANER, LLC
43 WASHINGTON AVENUE, PORTLAND

CONSTRUCTION

HEMESphere
DESIGN LLC

PROSPECT DESIGN
ARCHITECTURE | EXHIBITIONS
207.749.7400 | prospectdesign.me

A-105