

DISPLAY THIS CARD ON PRINCIPAL FRONTAGE OF WORK



# CITY OF PORTLAND BUILDING PERMIT

This is to certify that Fox Street Realty

Located At 109 FOX ST

Job ID: 2012-02-3317-HVAC

CBL: 023- A-008-001

has permission to Install a rooftop Trane HVAC (Brewery)

provided that the person or persons, firm or corporation accepting this permit shall comply with all of the provisions of the Statutes of Maine and of the Ordinances of the City of Portland regulating the construction, maintenance and use of the buildings and structures, and of the application on file in the department.

Notification of inspection and written permission procured before this building or part thereof is lathed or otherwise closed-in. 48 HOUR NOTICE IS REQUIRED.

A final inspection must be completed by owner before this building or part thereof is occupied. If a certificate of occupancy is required, it must be

Fire Prevention Officer

Code Enforcement Officer / Plan Reviewer

THIS CARD MUST BE POSTED ON THE STREET SIDE OF THE PROPERTY  
PENALTY FOR REMOVING THIS CARD

## BUILDING PERMIT INSPECTION PROCEDURES

Please call 874-8703 or 874-8693 (ONLY)

or email: [buildinginspections@portlandmaine.gov](mailto:buildinginspections@portlandmaine.gov)

With the issuance of this permit, the owner, builder or their designee is required to provide adequate notice to the city of Portland Inspections Services for the following inspections. Appointments must be requested 48 to 72 hours in advance of the required inspection. The inspection date will need to be confirmed by this office.

- **Please read the conditions of approval that is attached to this permit!! Contact this office if you have any questions.**
- **Permits expire in 6 months. If the project is not started or ceases for 6 months.**
- **If the inspection requirements are not followed as stated below additional fees may be incurred due to the issuance of a "Stop Work Order" and subsequent release to continue.**

The project cannot move to the next phase prior to the required inspection and approval to continue, REGARDLESS OF THE NOTICE OF CIRCUMSTANCES.

IF THE PERMIT REQUIRES A CERTIFICATE OF OCCUPANCY, IT MUST BE PAID FOR AND ISSUED TO THE OWNER OR DESIGNEE BEFORE THE SPACE MAY BE OCCUPIED.



# PORTLAND MAINE

*Strengthening a Remarkable City, Building a Community for Life • [www.portlandmaine.gov](http://www.portlandmaine.gov)*

Director of Planning and Urban Development  
Penny St. Louis

Job ID: 2012-02-3317-HVAC

Located At: 109 FOX ST

CBL: 023- A-008-001

## **Conditions of Approval:**

### **Zoning**

1. This permit is being approved on the basis of plans submitted. Any deviations shall require a separate approval before starting that work.
2. This I-Lb zone has maximum noise allowances. The City of Portland strictly enforces the level of sound generated on the property. Any verified noise violations shall require the owner to take mitigating measures to bring the property and the noise it generates into compliance.

**City of Portland, Maine - Building or Use Permit Application**

389 Congress Street, 04101 Tel: (207) 874-8703, FAX: (207) 8716

Job No: 2012-02-3317-HVAC	Date Applied: 2/17/2012	CBL: 023- A-008-001	
Location of Construction: 109 FOX ST	Owner Name: FOX STREET REALTY LLC	Owner Address: 299 FOREST AVE PORTLAND, ME 04101	Phone:
Business Name:	Contractor Name: HVAC Services Inc.	Contractor Address: 73 BRADLEY DR WESTBROOK MAINE 04092	Phone: 854-4822
Lessee/Buyer's Name:	Phone:	Permit Type: HVAC	Zone: I-Lb
Past Use: <b>Truck Repair/commercial laundry/light manufacturing</b>	Proposed Use: <b>Same: Truck repair/commercial laundry and light manufacturing – to install Trane roof top unit</b>	Cost of Work: \$15,000.00	CEO District:
		Fire Dept: <i>MA</i> Approved Denied N/A	Inspection: Use Group: Type: <i>HVAC</i>
		Signature: <i>[Signature]</i>	Signature: <i>[Signature]</i>
Proposed Project Description: Install Trane rooftop		Pedestrian Activities District (P.A.D.)	

Permit Taken By: Brad	<b>Zoning Approval</b>		
<p>1. This permit application does not preclude the Applicant(s) from meeting applicable State and Federal Rules.</p> <p>2. Building Permits do not include plumbing, septic or electrical work.</p> <p>3. Building permits are void if work is not started within six (6) months of the date of issuance. False informatin may invalidate a building permit and stop all work.</p>	<b>Special Zone or Reviews</b>	<b>Zoning Appeal</b>	<b>Historic Preservation</b>
	<input type="checkbox"/> Shoreland <input type="checkbox"/> Wetlands <input type="checkbox"/> Flood Zone <input type="checkbox"/> Subdivision <input type="checkbox"/> Site Plan  <input type="checkbox"/> Maj <input type="checkbox"/> Min <input type="checkbox"/> MM Date:	<input type="checkbox"/> Variance <input type="checkbox"/> Miscellaneous <input type="checkbox"/> Conditional Use <input type="checkbox"/> Interpretation <input type="checkbox"/> Approved <input type="checkbox"/> Denied Date:	<input type="checkbox"/> Not in Dist or Landmark <input type="checkbox"/> Does not Require Review <input type="checkbox"/> Requires Review <input type="checkbox"/> Approved <input type="checkbox"/> Approved w/Conditions <input type="checkbox"/> Denied Date:

**CERTIFICATION**

I hereby certify that I am the owner of record of the named property, or that the proposed work is authorized by the owner of record and that I have been authorized by the owner to make this application as his authorized agent and I agree to conform to all applicable laws of this jurisdiction. In addition, if a permit for work described in the application is issued, I certify that the code official's authorized representative shall have the authority to enter all areas covered by such permit at any reasonable hour to enforce the provision of the code(s) applicable to such permit.

SIGNATURE OF APPLICANT	ADDRESS	DATE	PHONE
RESPONSIBLE PERSON IN CHARGE OF WORK, TITLE		DATE	PHONE



FILL IN AND SIGN WITH INK

Entered 2/17 (15)

# APPLICATION FOR PERMIT HEATING OR POWER EQUIPMENT

I-Lb 003 A008 byeg OK

To the INSPECTOR OF BUILDINGS, PORTLAND, ME.

The undersigned hereby applies for a permit to install the following heating, cooking or power equipment in accordance with the Laws of Maine, the Building Code of the City of Portland, and the following specifications:

Location / CBL 103 Fox St Portland ME Use of Building Brewery Date 2-  
 Name and address of owner of appliance Cardente Doug  
322 Fore St 3rd Floor Portland ME 04101  
 Installer's name and address HVAC SERVICES  
13 Bradley Drive Westbrook ME 04092 Telephone 8544822

### Location of appliance:

- Basement
- Floor
- Attic
- Roof

### Type of Fuel:

- Gas
- Oil
- Solid

Appliance Name: TRANE Rooftop

U.L. Approved  Yes  No

Will appliance be installed in accordance with the manufacture's installation instructions?  Yes  No

IF NO Explain: \_\_\_\_\_

### The Type of License of Installer:

- Master Plumber # \_\_\_\_\_
- Solid Fuel # \_\_\_\_\_
- Oil # \_\_\_\_\_
- Gas # PNT1058
- Other \_\_\_\_\_

### Type of Chimney:

- Masonry Lined  
Factory built N/A
- Metal  
Factory Built U.L. Listing # N/A
- Direct Vent  
Type \_\_\_\_\_ UL# \_\_\_\_\_

### Type of Fuel Tank

- Oil
- Gas

Size of Tank \_\_\_\_\_

Number of Tanks \_\_\_\_\_

Distance from Tank to Center of Flame \_\_\_\_\_ feet.

Cost of Work: \$ 14,750 14,000 30

Permit Fee: \$ 170.00

Charge 1430.00

RECEIVED  
FEB 17 2012  
DEPT. OF PERMITS & INSPECTION

Approved

- 27.00 Approved with Conditions

- See attached letter or requirement

Fire: \_\_\_\_\_  
 Ele.: \_\_\_\_\_  
 Bldg.: \_\_\_\_\_

Inspector's Signature

Date Approved

Signature of Installer [Signature]



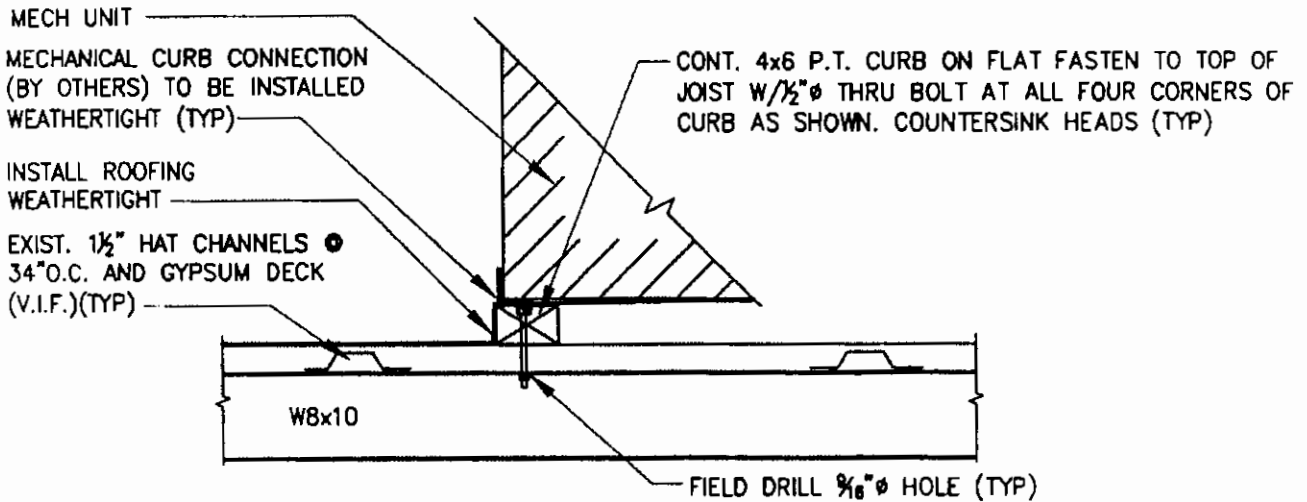

**SECTION 2**  
3/4" = 1'-0"

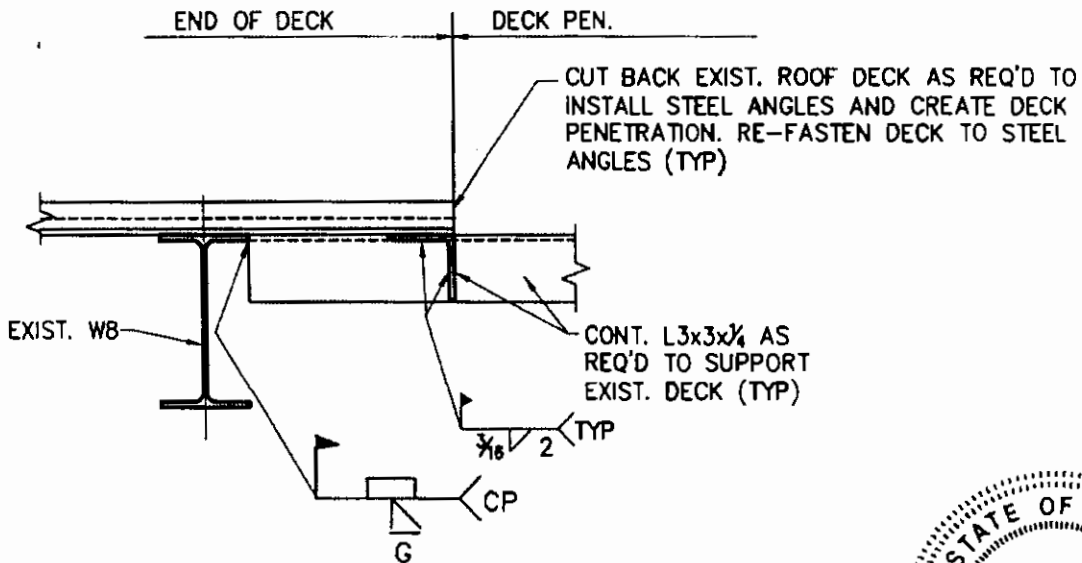

**TYP. DECK PEN. DETAIL**  
1 1/2" = 1'-0"



2012-010

designed by:	JHL
drawn by:	AKB
checked by:	JHL
scale:	AS NOTED
date:	2-14-12

101 & 103 FOX STREET  
PORTLAND, MAINE  
HVAC SUPPORT  
SECTIONS AND DETAILS

L & L STRUCTURAL  
ENGINEERING SERVICES, INC.  
SIX Q STREET  
SOUTH PORTLAND, MAINE 04106

PHONE: (207) 767-4830  
FAX: (207) 799-5432



**TRANE**

## Packaged Rooftops

---

**Precedent™ 3-10 Tons – 60 Hz  
R-410A**

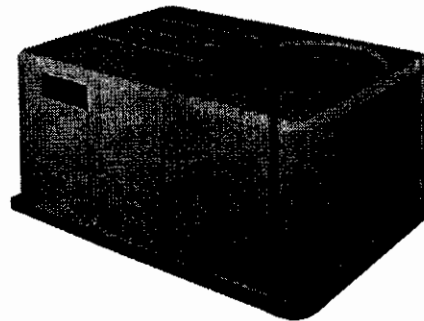

**Packaged Cooling, Heat Pumps (T\*C), (WSC)**

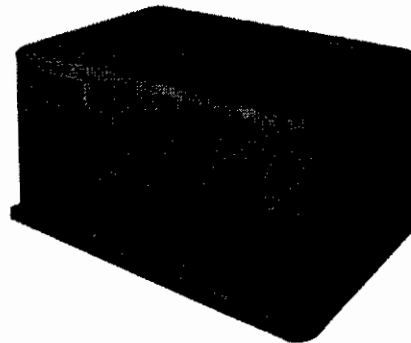

**Packaged Gas/Electric (Y\*C)**



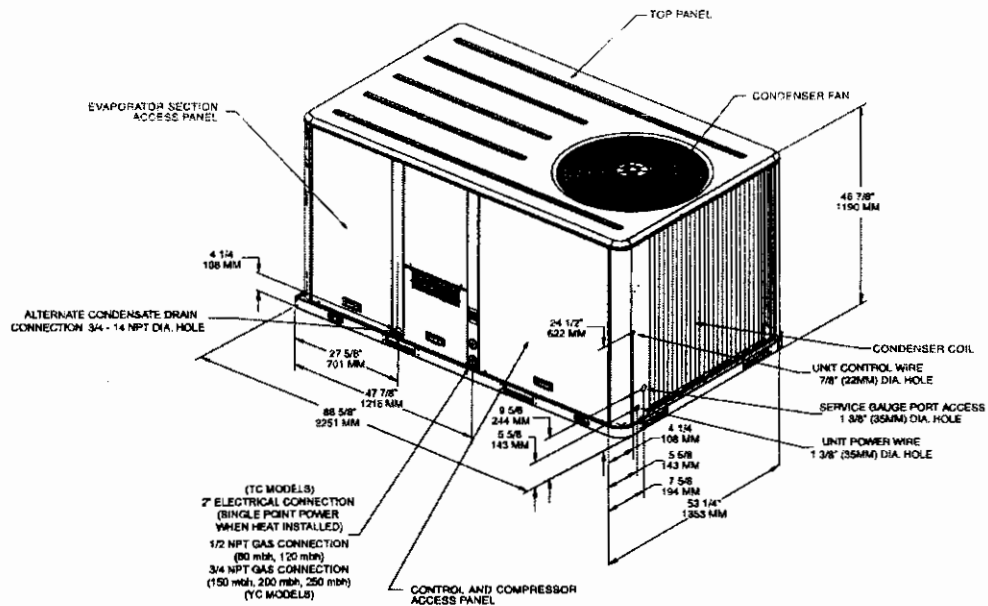

**Figure 19. Cooling and Gas/Electric Models - 7½, 8½ and 10 Tons Standard Efficiency**  
 \* All dimensions are in inches/millimeters.  
 \*\* 1/2 NPT & 3/4" Gas Connection = (Y\_C Models only); 2" Electrical Connection: Single Point Power When Heat Installed (T\_C Models only.)

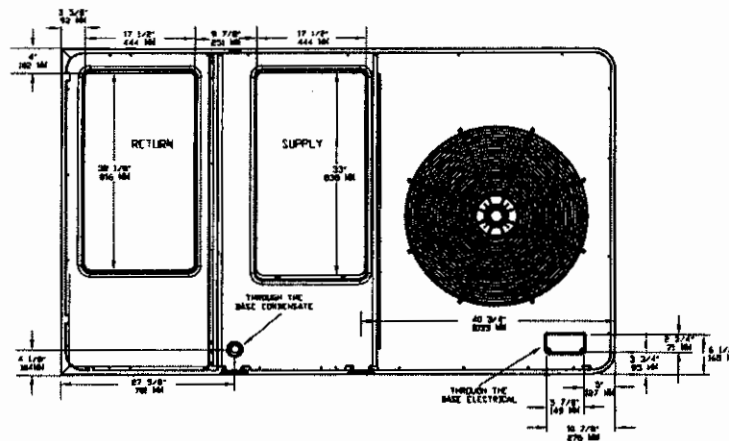

**Figure 20. Cooling and Gas/Electric - 7½-10 Tons Standard Efficiency**  
**Downflow Airflow Supply/Return Through the Base Utilities**  
 \* All dimensions are in inches/millimeters.



# CITY OF PORTLAND, MAINE

Department of Building Inspections

## Original Receipt

2/17 2012

Received from HVAC Services

Location of Work 91-193 Fox St.

Cost of Construction \$ 14750 Building Fee: \_\_\_\_\_

Permit Fee \$ \_\_\_\_\_ Site Fee: \_\_\_\_\_

Certificate of Occupancy Fee: \_\_\_\_\_

HVAC

Total: 143.00

Building (1L) \_\_\_\_\_ Plumbing (15) \_\_\_\_\_ Electrical (12) \_\_\_\_\_ Site Plan (U2) \_\_\_\_\_

Other \_\_\_\_\_

CBL: 023 A028

Check #: 42251 Total Collected \$ 143-

170 Due

**No work is to be started until permit issued.  
Please keep original receipt for your records.**

Taken by: \_\_\_\_\_

B

pd w/cc

see

add

receipt

WHITE - Applicant's Copy  
YELLOW - Office Copy  
PINK - Permit Copy



# CITY OF PORTLAND, MAINE

Department of Building Inspections

## Original Receipt

2/9/17 2012

Received from 109 Fox St (Brewery)

Location of Work HVAC Services

Cost of Construction \$ \_\_\_\_\_ Building Fee: \_\_\_\_\_

Permit Fee \$ \_\_\_\_\_ Site Fee: \_\_\_\_\_

Certificate of Occupancy Fee: \_\_\_\_\_

Total: 27.00

Building (IL) \_\_\_ Plumbing (IS) \_\_\_ Electrical (IE) \_\_\_ Site Plan (U2) \_\_\_

Other \_\_\_\_\_

CBL: 023 A008

Charge Check #: 035456

Total Collected \$ 27.00

Total Due

**No work is to be started until permit issued.  
Please keep original receipt for your records.**

Taken by: (Signature) Paid w cc

WHITE - Applicant's Copy  
YELLOW - Office Copy  
PINK - Permit Copy