

14 **SIDEWALK & DRIVEWAY CONSTRUCTION**  
NOT TO SCALE

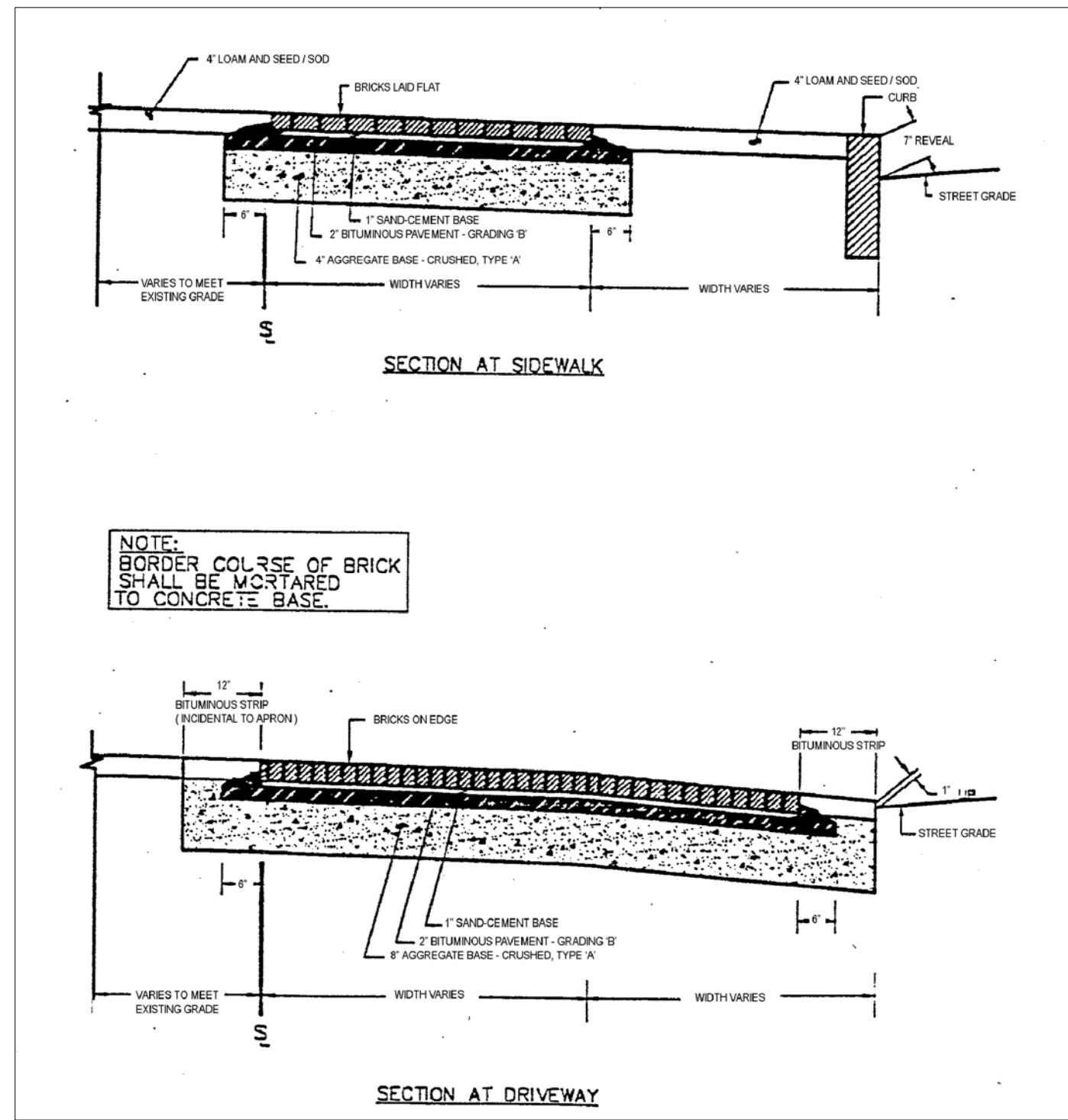

13 **BRICK SIDEWALK AND DRIVEWAY CONSTRUCTION**  
NOT TO SCALE

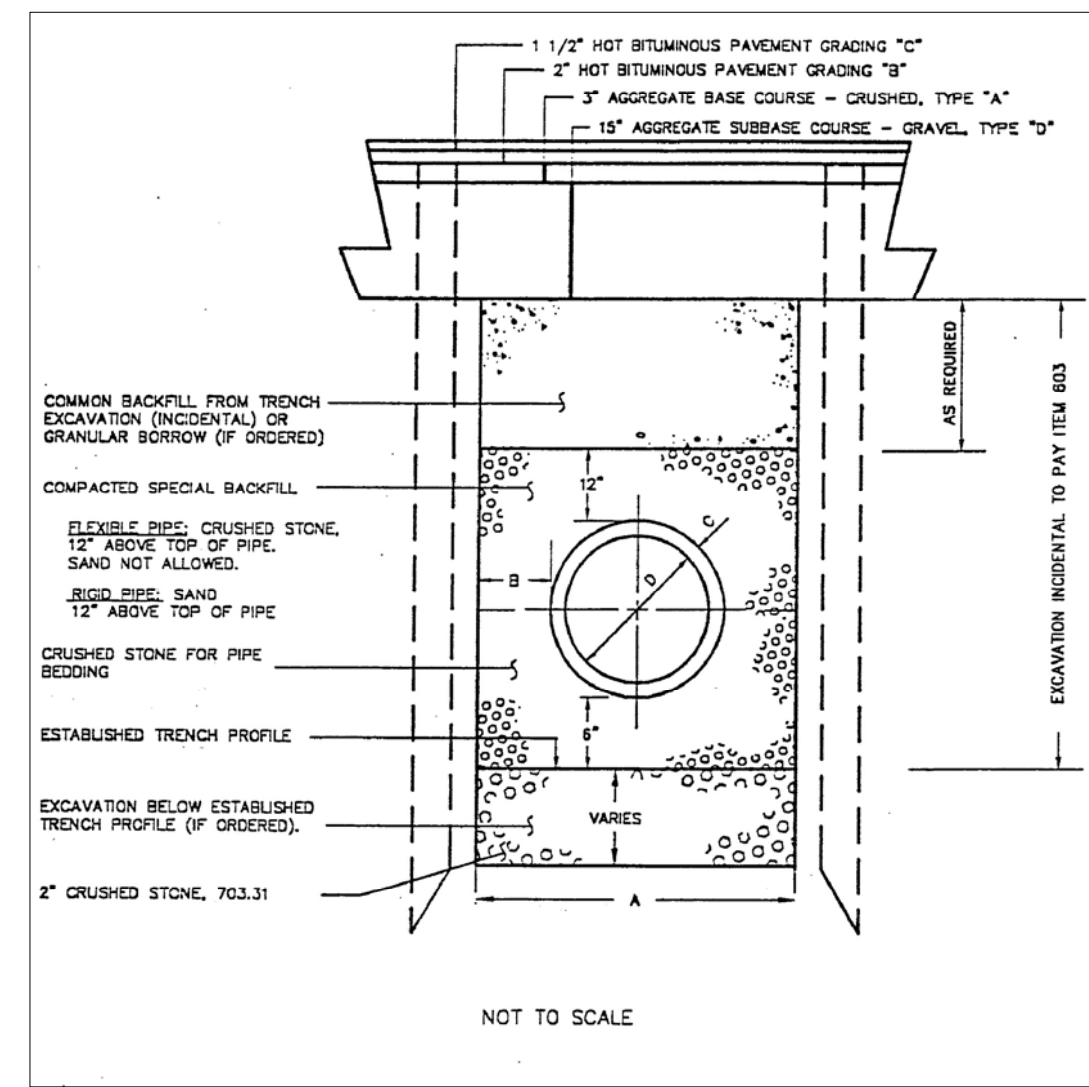

12 **TRENCH SECTION**  
NOT TO SCALE

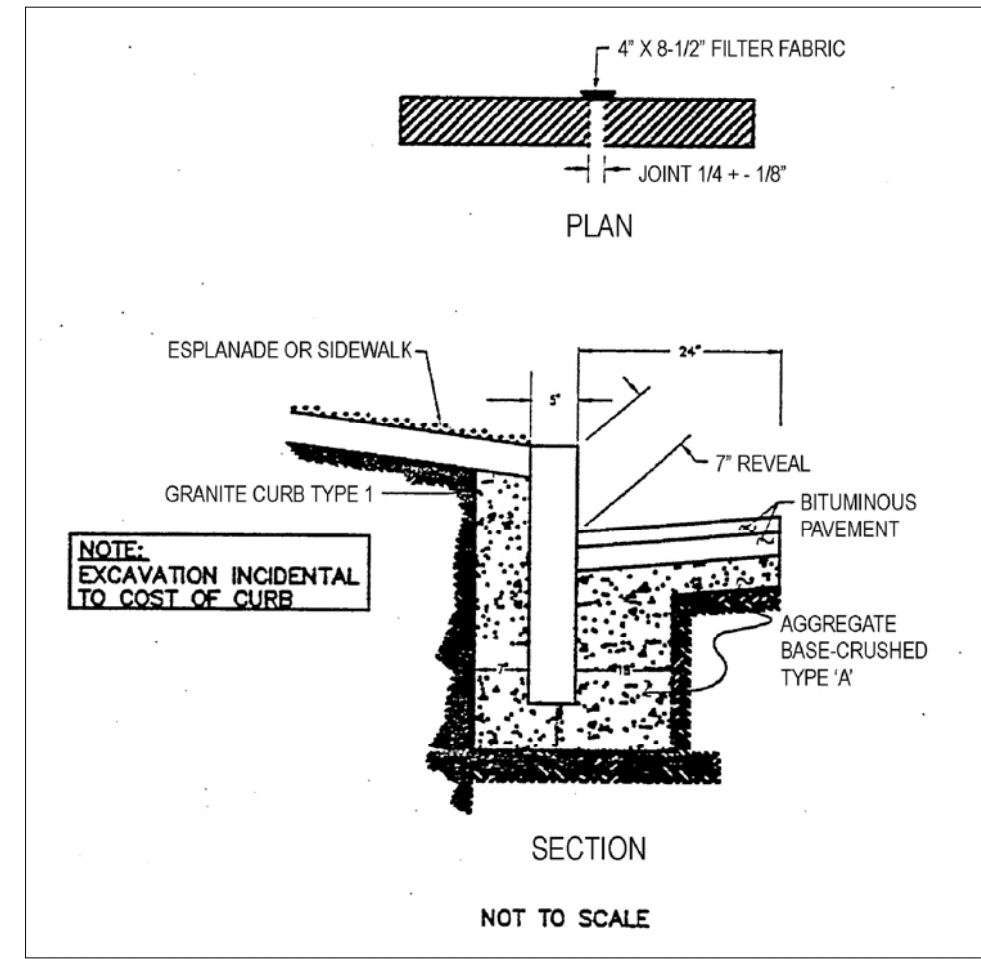

11 **REPLACEMENT CURB INSTALLATION**  
NOT TO SCALE

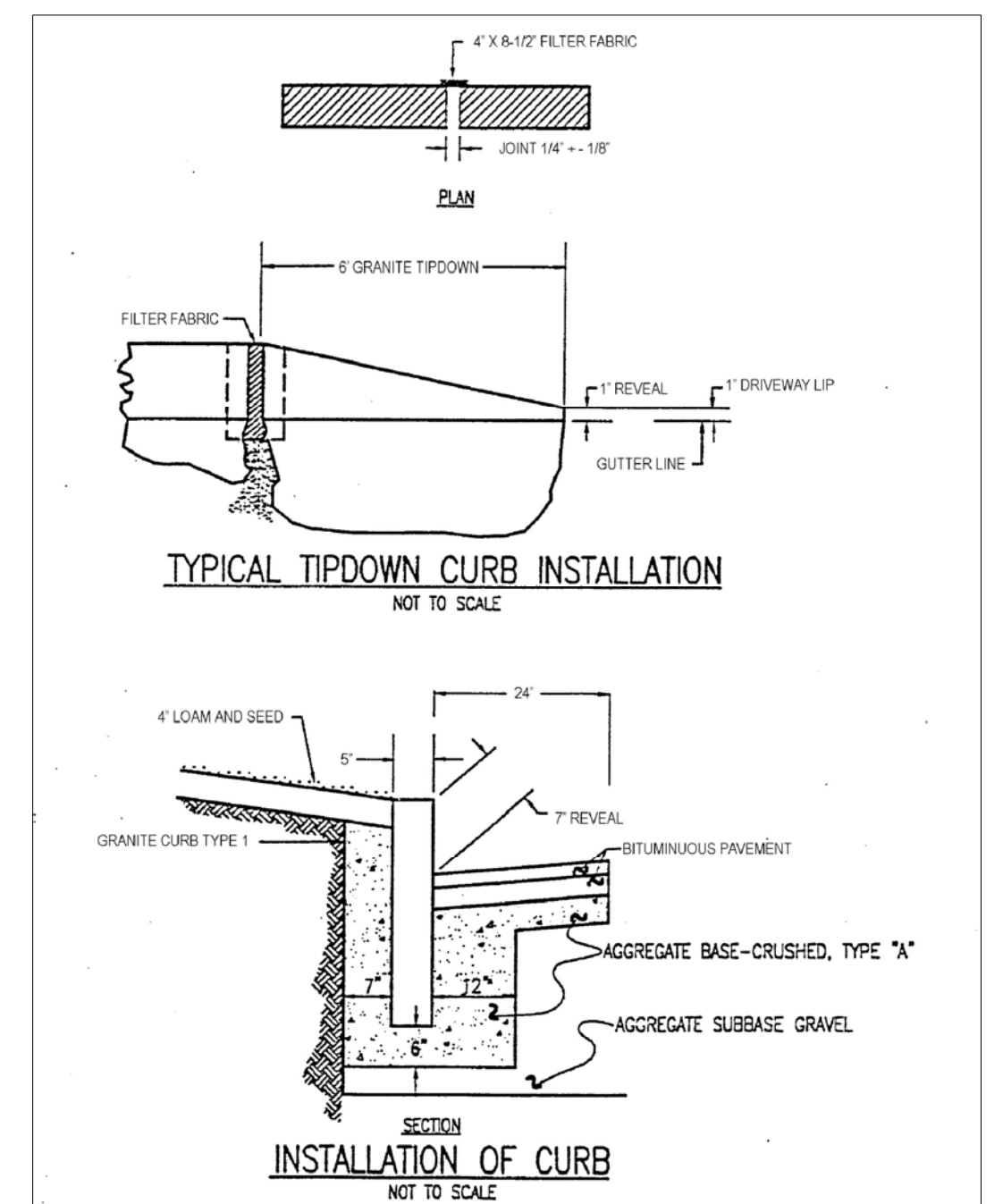

10 **CURB INSTALLATION**  
NOT TO SCALE

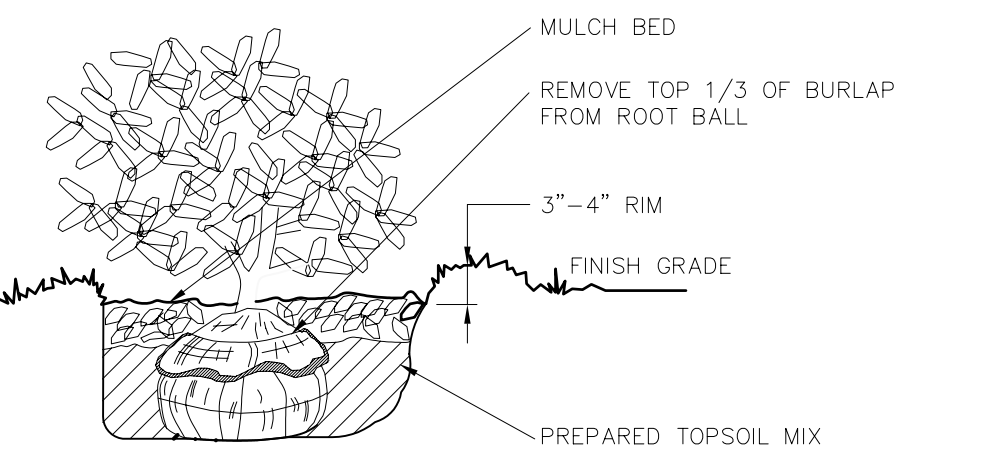

9 **SHRUB PLANTING DETAIL**  
NOT TO SCALE

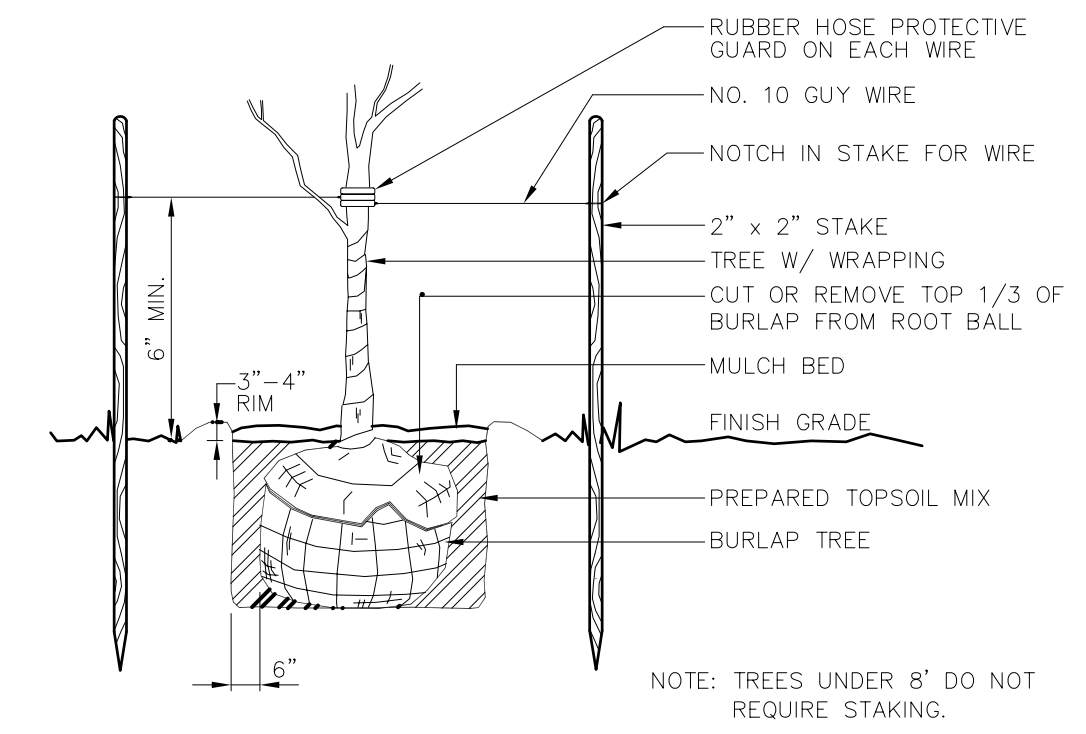

8 **TREE PLANTING DETAIL**  
NOT TO SCALE

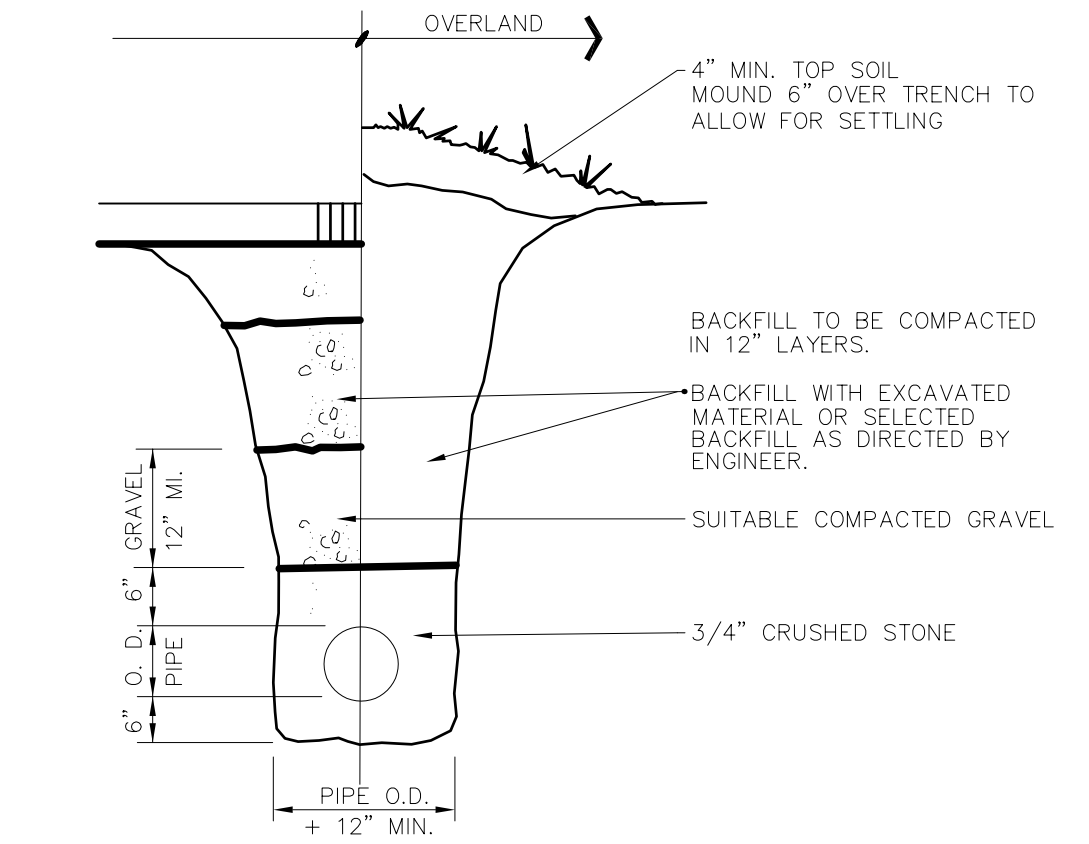

7 **TYPICAL TRENCH SECTION**  
NOT TO SCALE

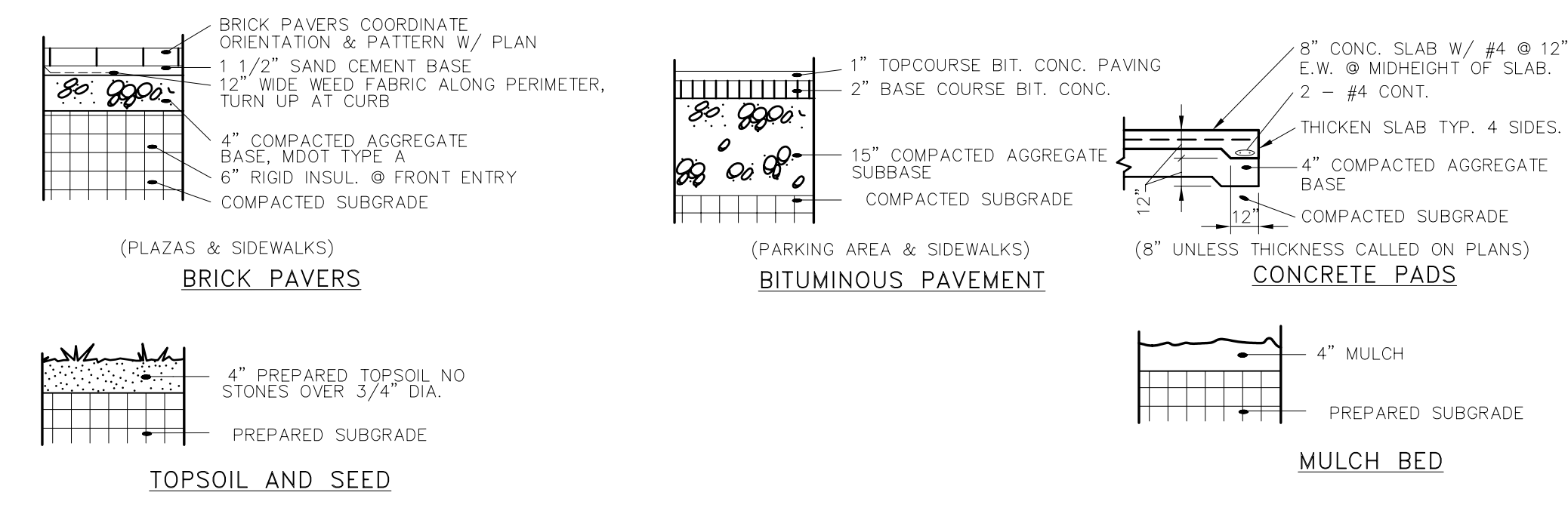

6 **SURFACING DETAILS**  
NOT TO SCALE

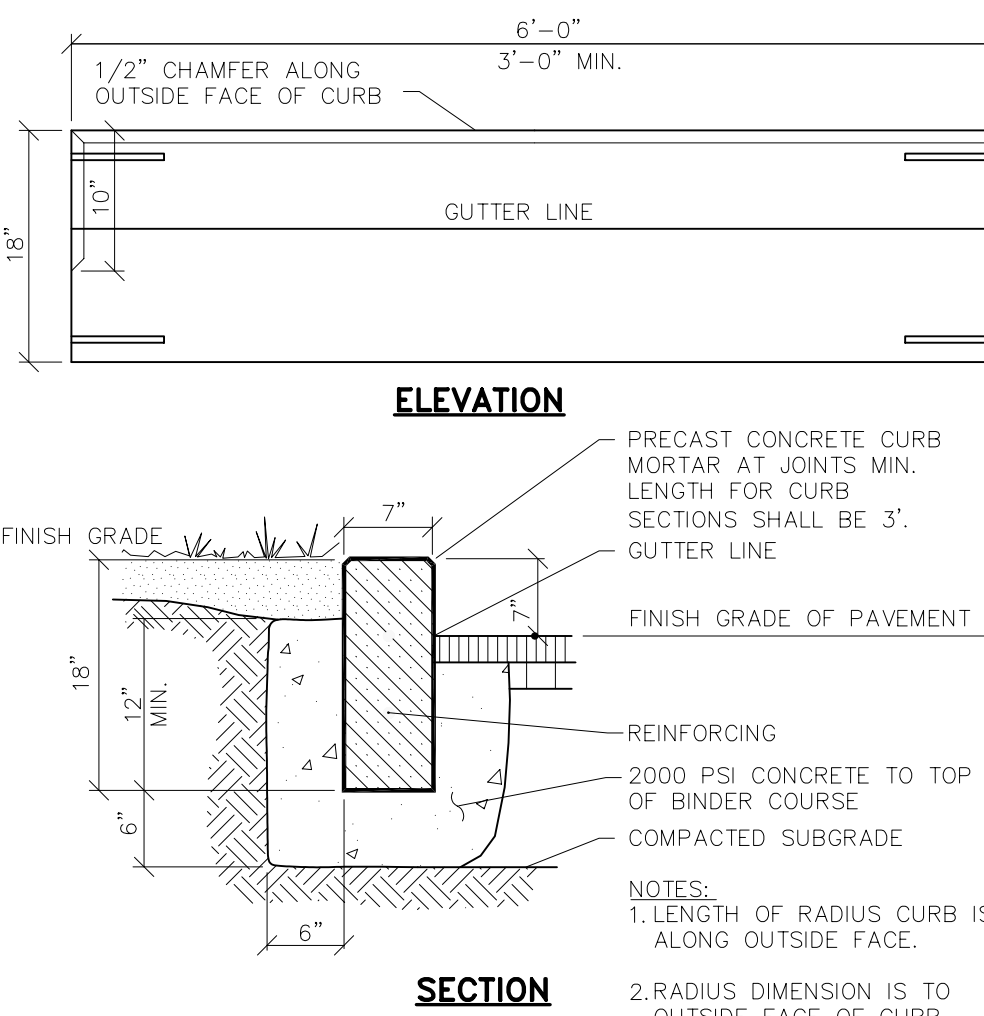

5 **PRECAST CONCRETE CURB DETAIL**  
NOT TO SCALE

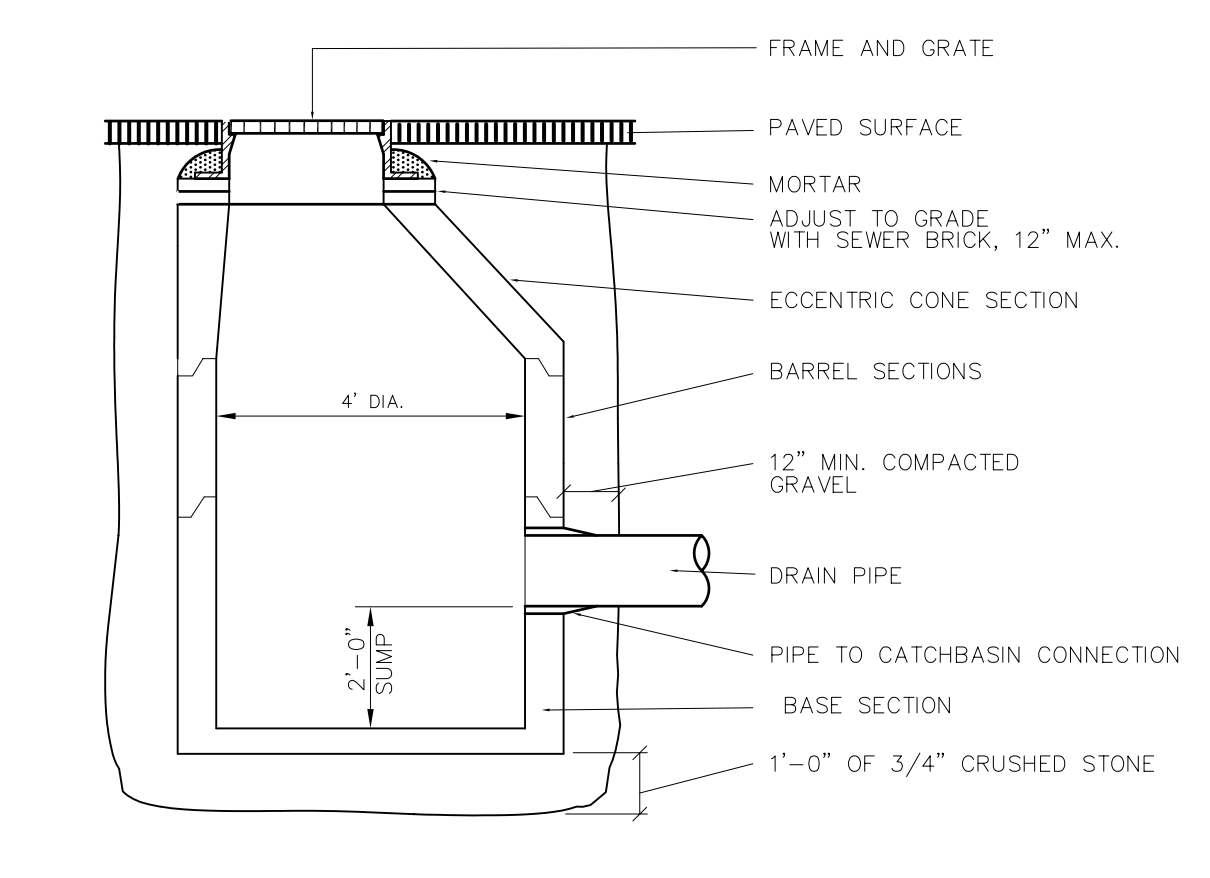

4 **CATCH BASIN W/ ECCENTRIC CONE SECTION**  
NOT TO SCALE

NOTES:  
1. ALL WOOD TO BE PRESSURE TREATED TO A MIN. NET OF .40 LBS. CCA PER CUBIC FOOT OF WOOD AND EACH PIECE SHALL BEAR THE AMERICAN WOOD PRESERVERS BUREAU QUALITY MARK LP-22 "GROUND CONTACT USE."  
2. ALL NAILS AND SCREWS TO BE STAINLESS.

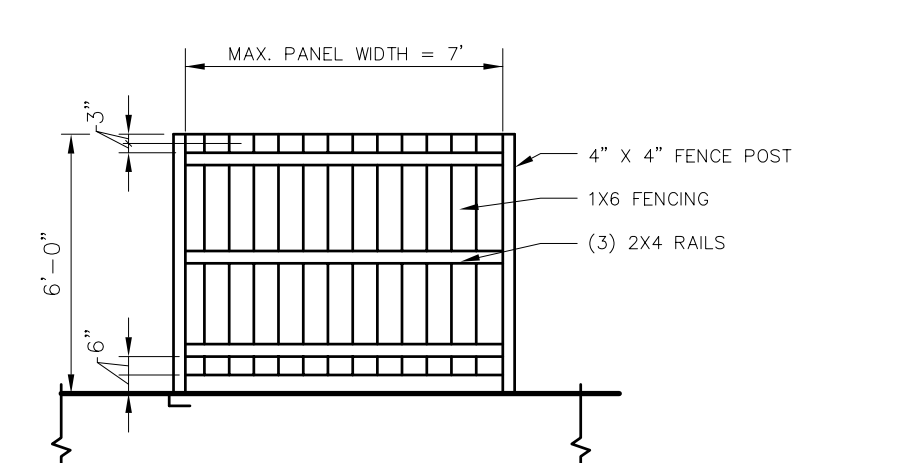

1 **STOCKADE FENCE DETAIL**  
NOT TO SCALE