

TYPICAL EFFICIENCY APARTMENT  
RISER DIAGRAM

SCALE: N.T.S.

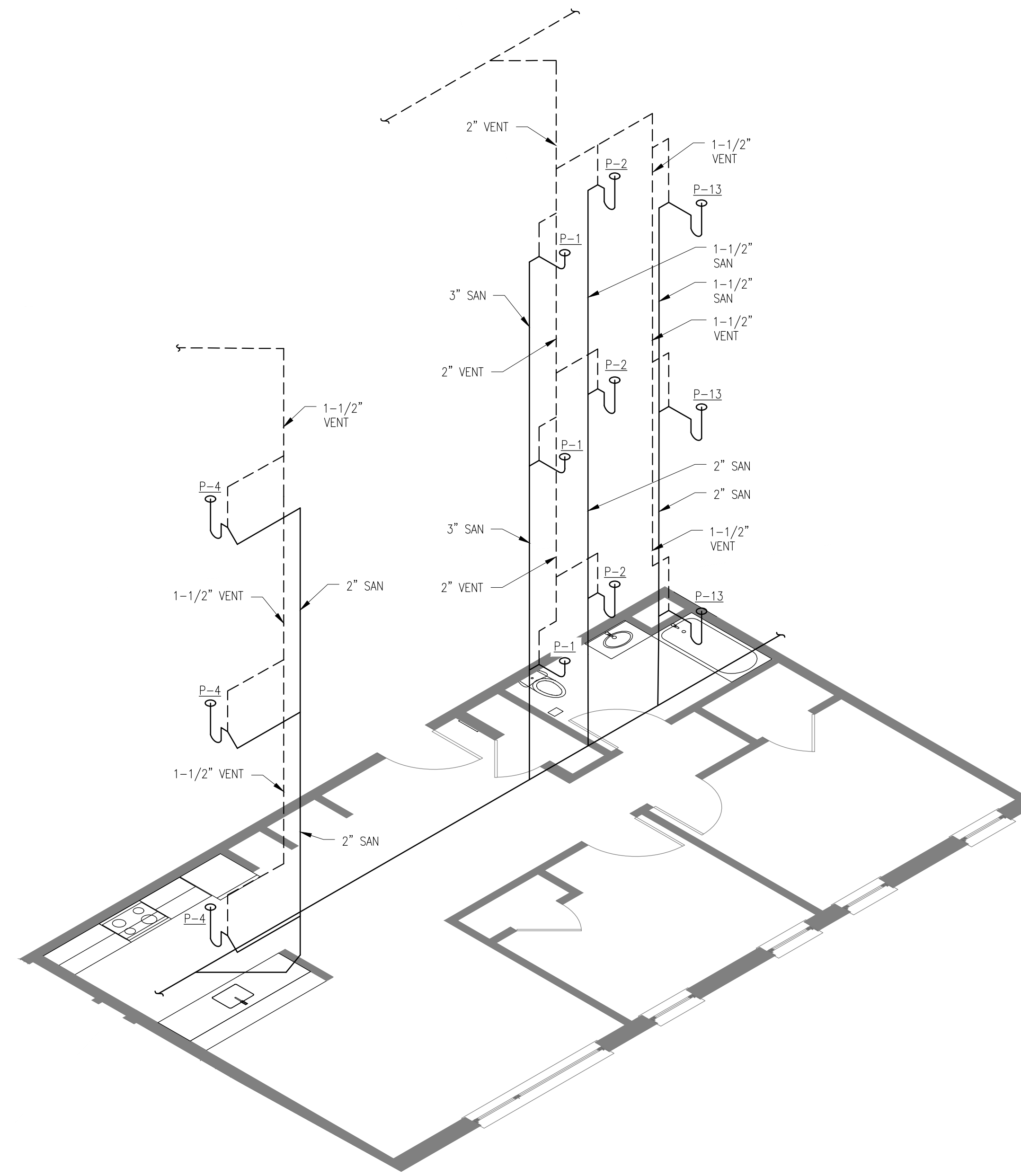

TYPICAL TWO BEDROOM APARTMENT  
RISER DIAGRAM

SCALE: N.T.S.

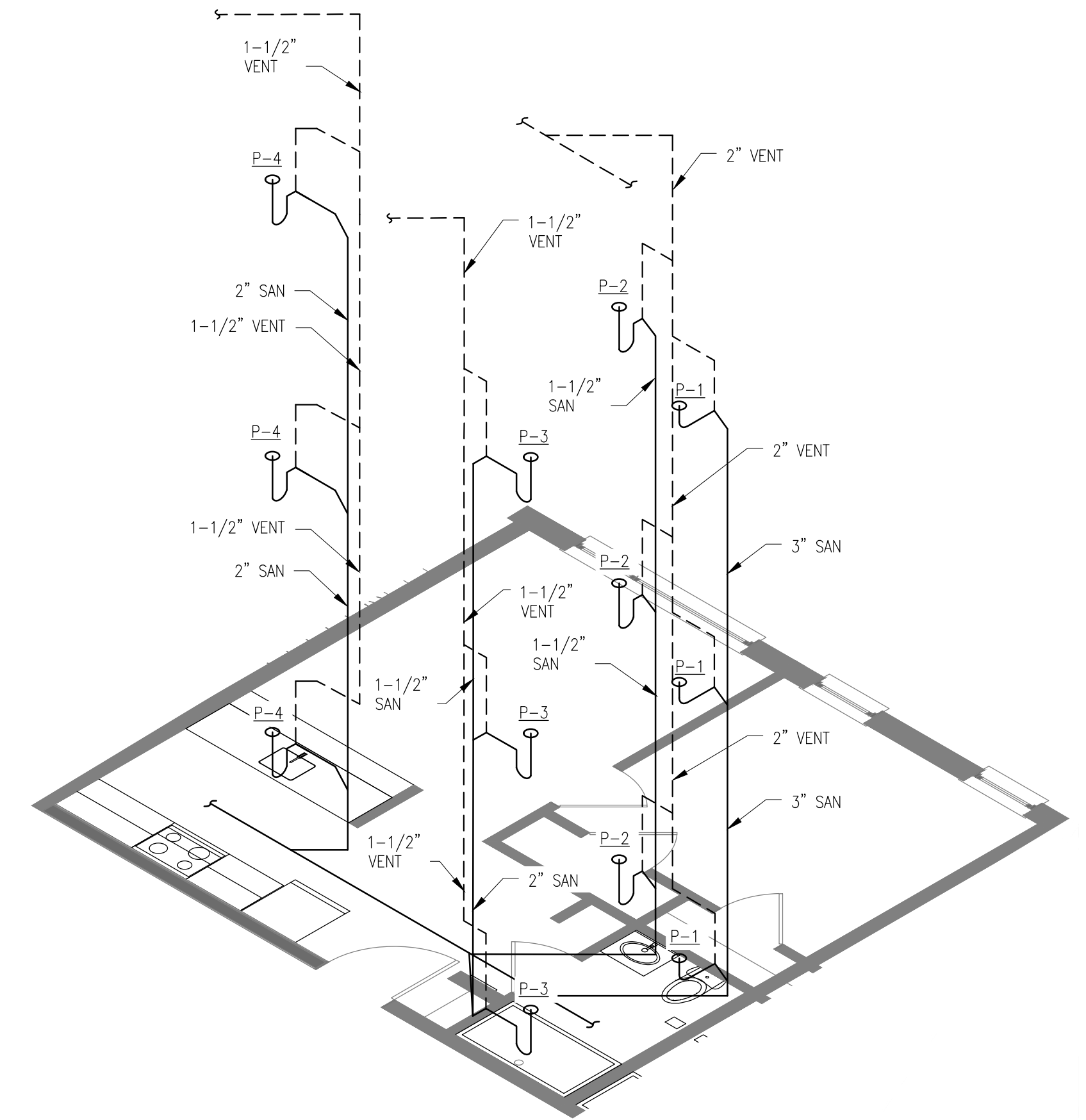

TYPICAL ONE BEDROOM APARTMENT  
RISER DIAGRAM

SCALE: N.T.S.



424 FORE ST.  
PORTLAND, ME 04101  
P: 207.842.2888



14 BAXTER BLVD  
PORTLAND, ME 04101  
P: 207.773.4753



307 CUMBERLAND AVE  
PORTLAND, ME 04101  
P: 207.553.7777



217 COMMERCIAL STREET, STE 200  
PORTLAND, MAINE 04101  
207.772.1552 V. F. 207.772.0712



75 YORK ST.  
PORTLAND, ME 04101  
P: 207.879.1838



400 COMMERCIAL ST.  
SUITE 404  
PORTLAND, ME 04101  
P: 207.772.2891



190 US ROUTE ONE  
PMB 346 FALMOUTH, ME  
04105  
P: 207.847.3445

# PRICING DOCUMENTS

Project:  
BAYSIDE ANCHOR  
PHDC & Avesta  
81 East Oxford Street  
Portland, ME

Drawing: PLUMBING - WASTE, DRAIN, & VENTING TYPICAL RISER DIAGRAMS

Scale: N.T.S.

Drawn by: AEW

Date: 9/1/15

Revised:

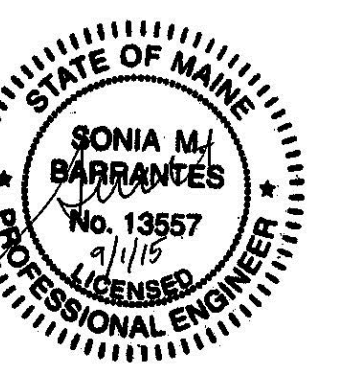

PL200