

1 AHU-119 MOUNTING DETAIL - ALTERNATE
SCALE: 1/2" = 1'-0"

2 ERV-1 & 2 MOUNTING DETAIL - ALTERNATE
SCALE: 1/2" = 1'-0"

3 ERV-3 & 4 MOUNTING DETAIL
SCALE: 1/2" = 1'-0"

4 UPPER FLOOR ERV MOUNTING DETAIL
SCALE: 1/2" = 1'-0"

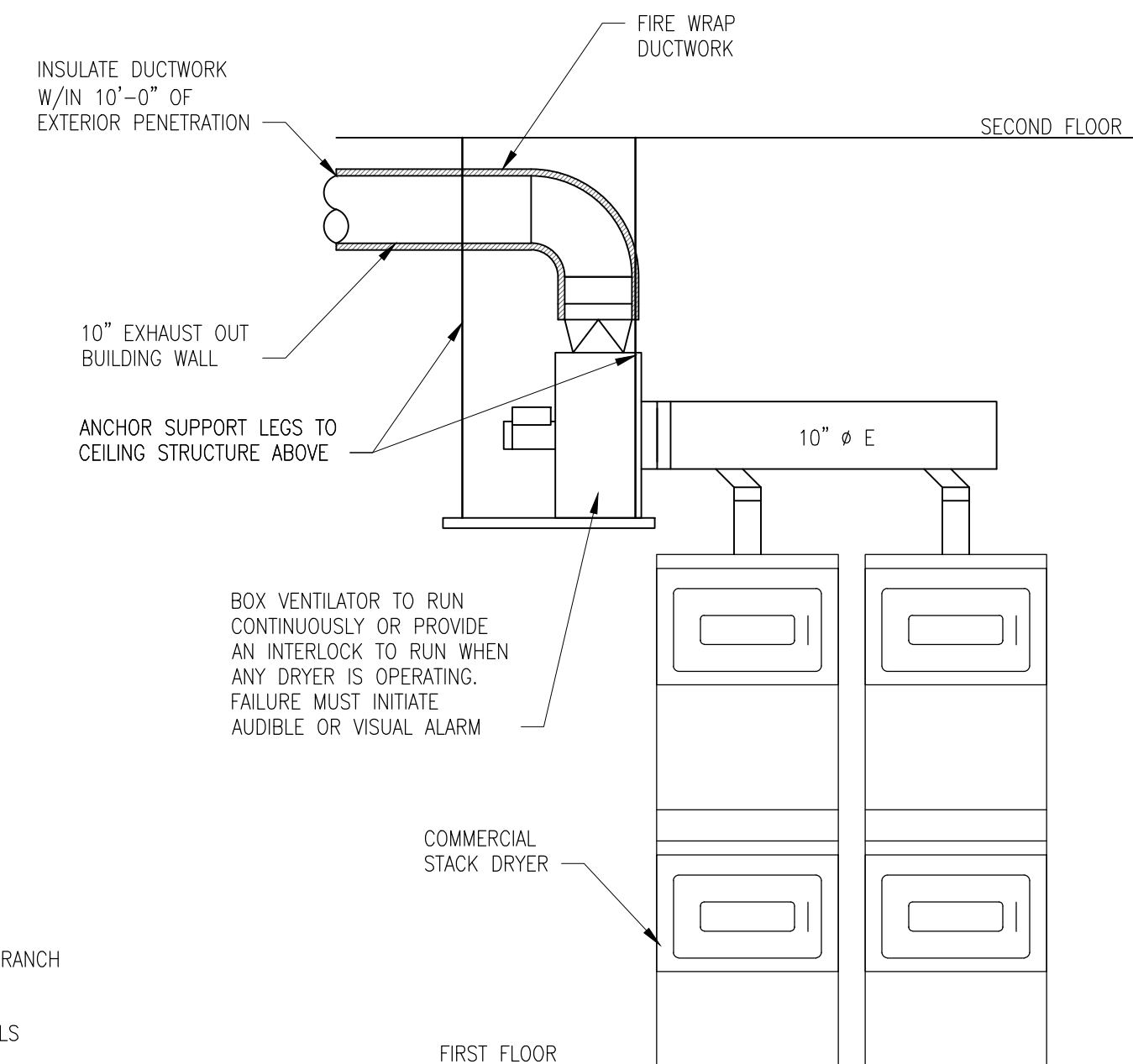
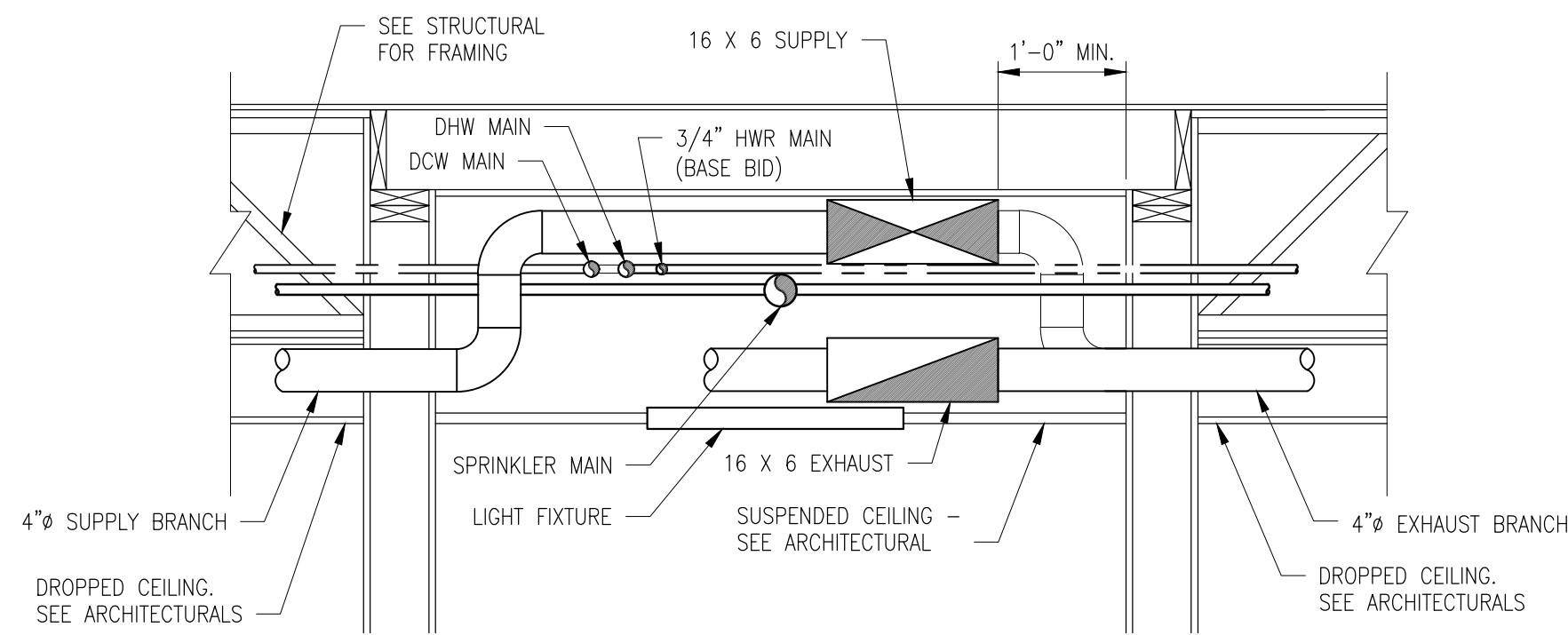
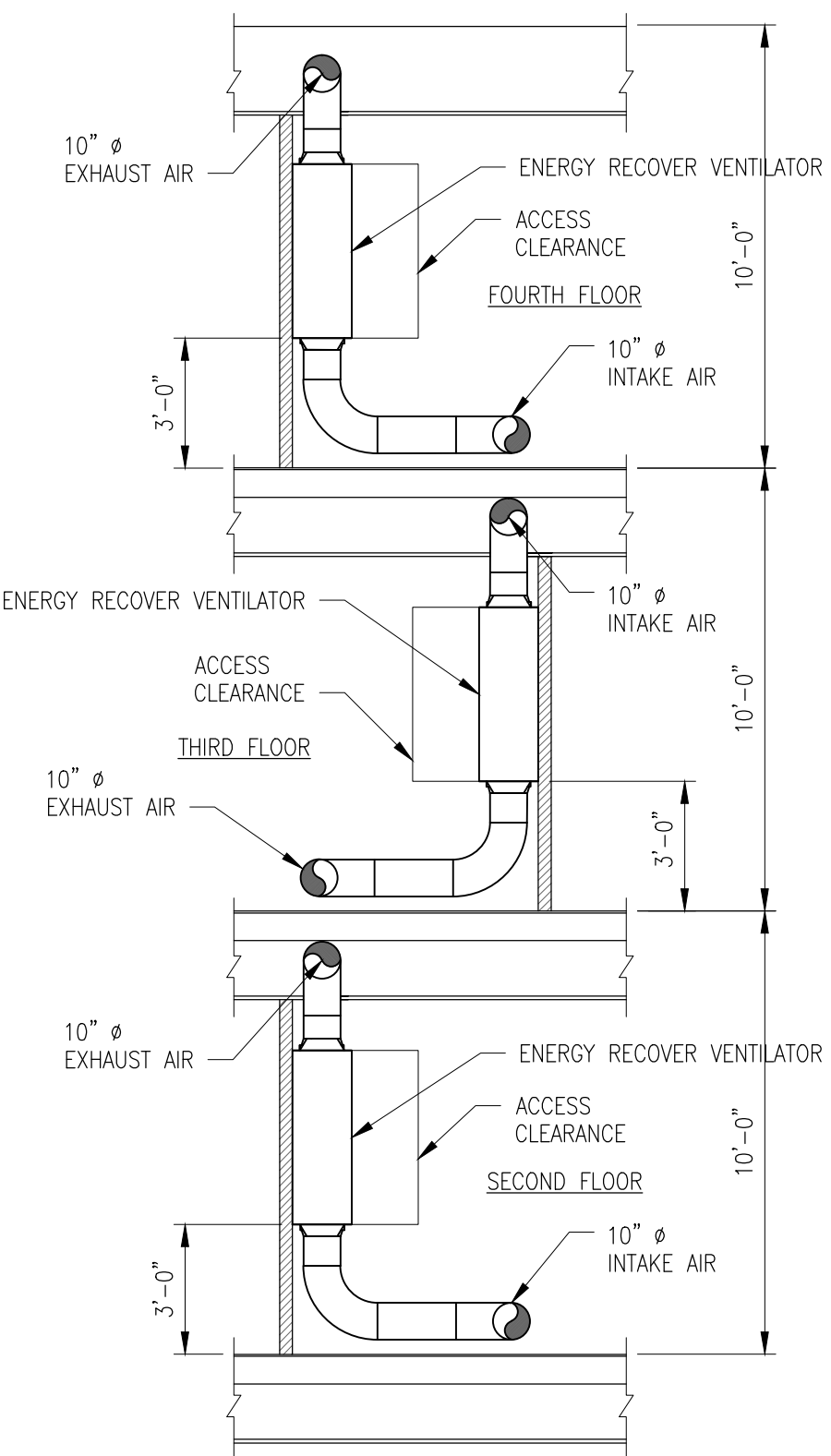

5 SECTION AT UPPER FLOOR ERVS
SCALE: 1/4" = 1'-0"

6 SERVICE DETAIL AT CORRIDOR CEILINGS
SCALE: 3/4" = 1'-0"

7 DRYER EXHAUST SYSTEM ELEVATION
SCALE: 1/2" = 1'-0"

NOTE:
1. DETAIL REFLECTS SECOND AND FOURTH FLOOR CONDITIONS. DUCTWORK IS REVERSED ON THIRD FLOOR.

NOTES:
1. INSTALLATION OF EXHAUST & MAKEUP AIR SHALL CONFORM TO IMC.
2. DUCTS REQUIRE 6" CLEARANCE TO COMBUSTIBLES PER IMC.
3. ALL WALL OR CEILING PENETRATIONS SHALL BE FIRE CAULKED.