

REV.	DATE	STATUS
0	4-8-13	STATE FIRE MARSHAL SUBMISSION
1	4-25-13	ISSUED FOR PERMIT

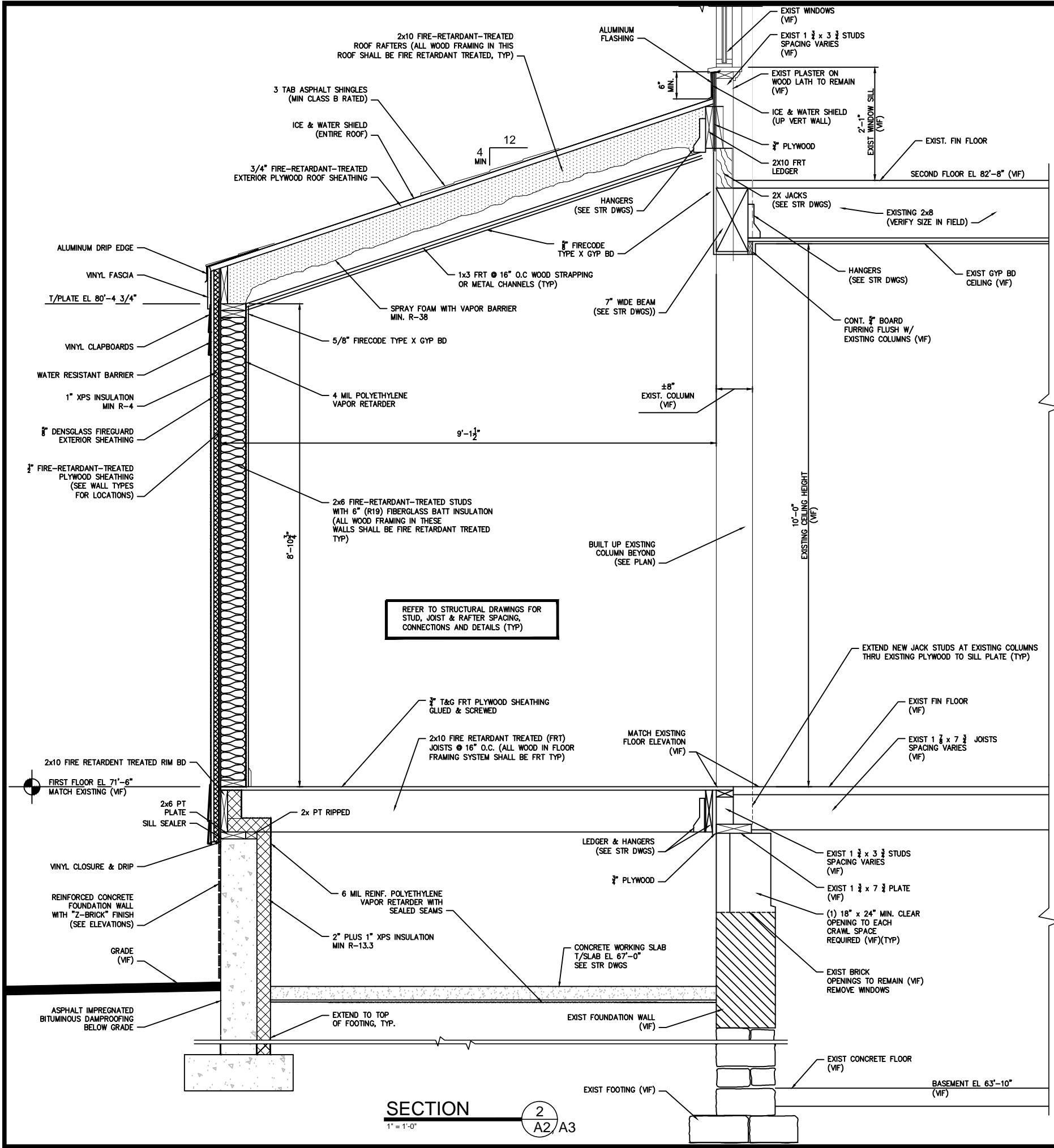

JOHN H. LEASURE ARCHITECT, INC.
6 Q STREET
SOUTH PORTLAND, MAINE 04106

A8



SECTION 2
1" = 1'-0"
A2, A3

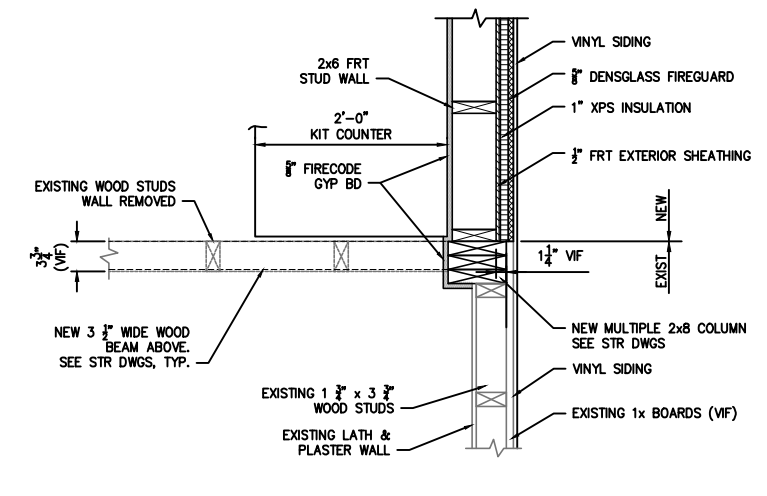

PLAN DETAIL B
1" = 1'-0"
A1, A2

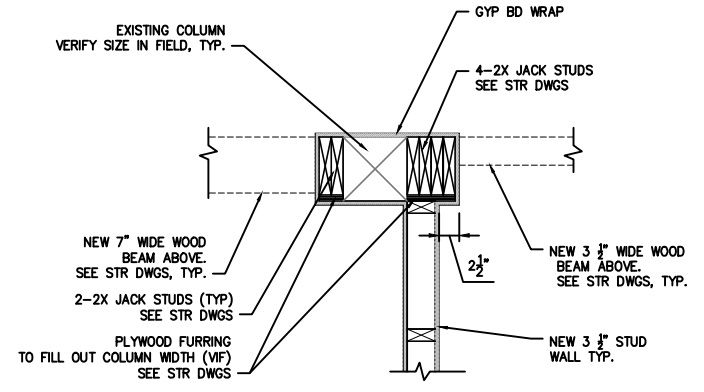

PLAN DETAIL C
1" = 1'-0"
A2

ETZ CHAIM SYNAGOGUE
267 CONGRESS STREET
PORTLAND, MAINE

SECTIONS AND DETAILS