

SUBMITTAL DATA: MSZ-FH12NA & MUZ-FH12NA
12,000 BTU/H WALL-MOUNTED HEAT PUMP SYSTEM

Job Name:

System Reference:

Date:

GENERAL FEATURES

- Highly energy-efficient system that features 100% heating capacity at 5°F, 82% at -4°F, and 62% at -13°F
- Updated sleek, compact indoor unit design
- Includes Standard, Platinum Deodorizing, and Anti-allergy Enzyme filters for a complete air purifying system
- “Powerful Mode” function permits system to temporarily run at a lower/higher temperature with an increased fan speed, which quickly brings the room to the optimum comfort level
- Integrated i-see Sensor automatically adjusts the unit’s operation according to temperature differences detected between the floor and the intake air, ensuring optimum comfort and energy usage
- Hand-held Wireless Remote Controller
- Base Pan Heater is available as an option
- Limited warranty: five years parts and seven years compressors

ACCESSORIES
Outdoor Unit

- Base Pan Heater (MAC-640BH-U)
- Drain Socket (MAC-860DS)

Indoor Unit

- Condensate Pump (BlueDiamond X87-711/721; 115/230V)
- Condensate Pump (Sauermann SI30-115/230; 115/230V)
- Replacement Platinum Deodorizing Filter (MAC-3000FT-E)
- Replacement Anti-allergy Enzyme Filter (MAC-2330FT-E)

Controller Options

- Wireless Wall-mounted Remote Controller Kit (MHK1)*
- Portable Central Controller (MCCH1)*
- Outdoor Air Sensor (MOS1)*
- Wired Wall-mounted Controller (PAR-31MAA requires MAC-333IF)*
- Simple MA Remote Controller (PAC-YT53CRAU requires MAC-333IF)*

*See Submittal for information on each option

- System Control Interface (MAC-333IF)
- Remote Temperature Sensor (M21-JKO-307)
- Lockdown Bracket for Hand-held Controller (RCMKP1CB)



DIMENSIONS: MSZ-FH12NA & MUZ-FH12NA

MSZ-FH12NA

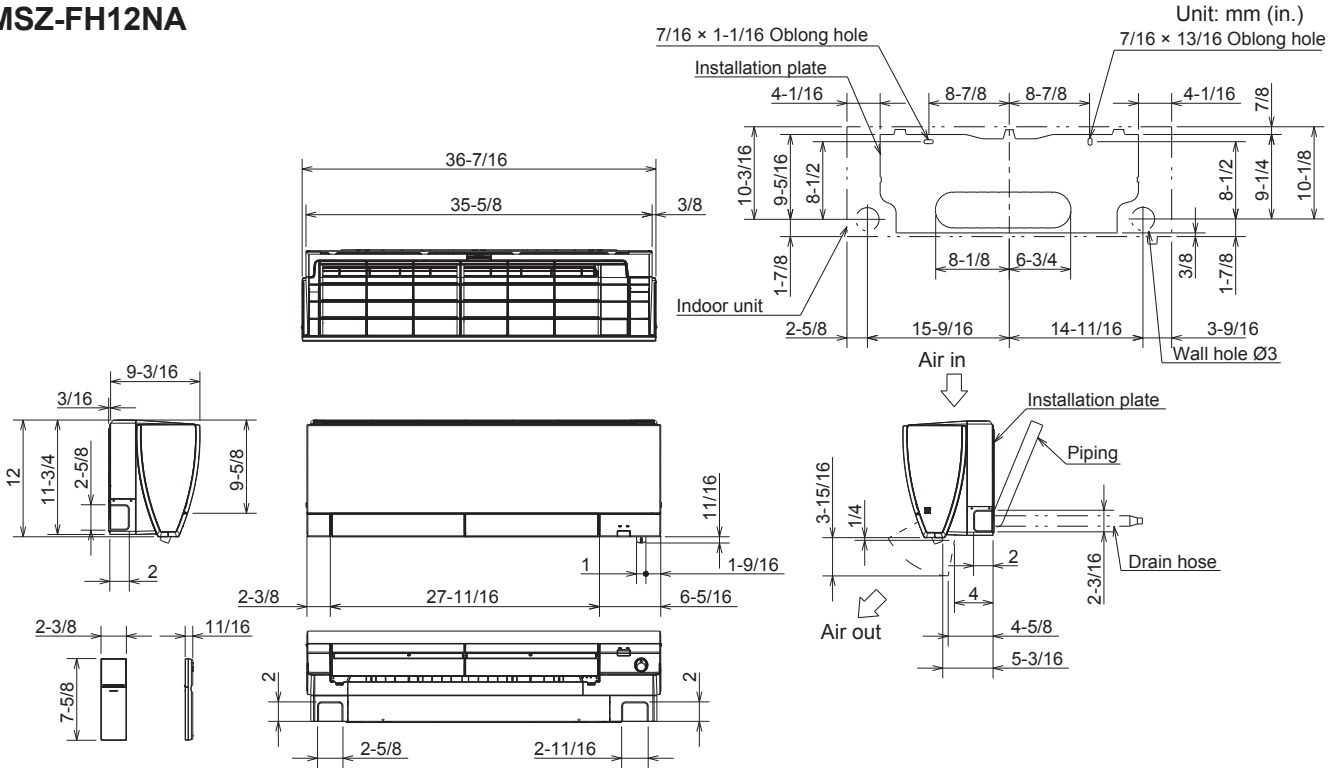

MUZ-FH12NA

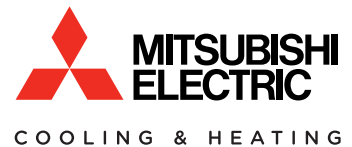
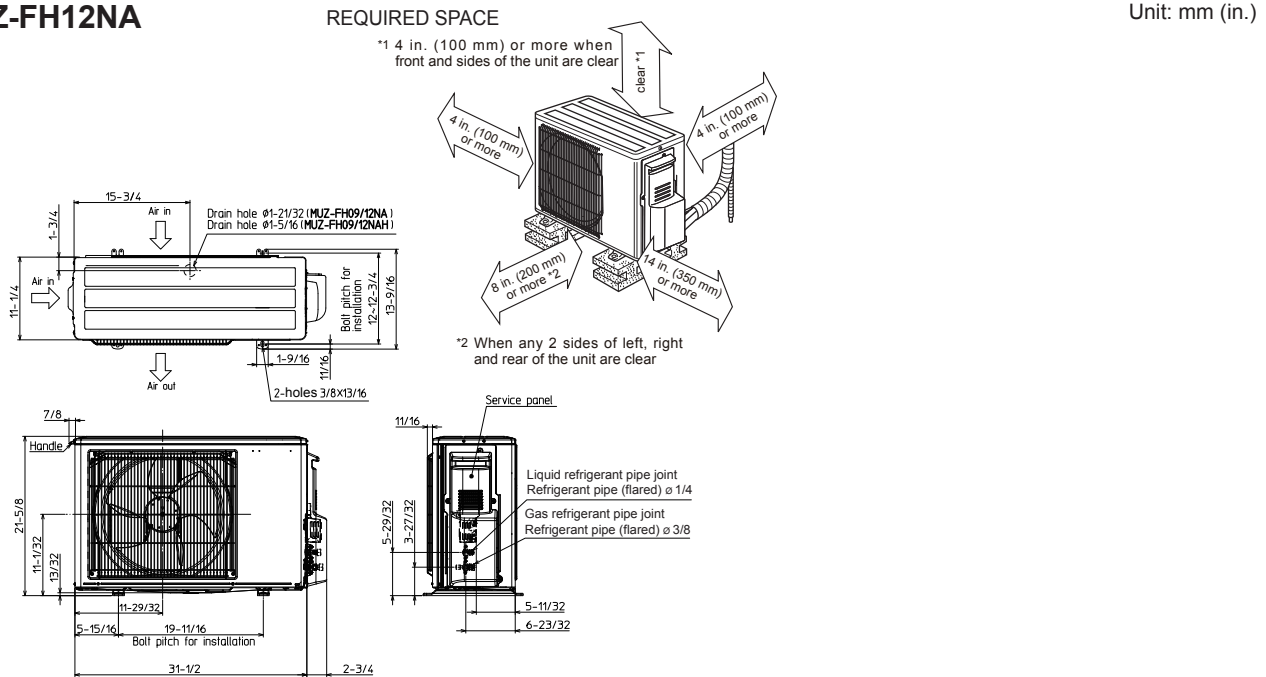

1340 Satellite Boulevard
 Suwanee, GA 30024
 Tele: 678-376-2900 • Fax: 800-889-9904
 Toll Free: 800-433-4822
 www.mehvac.com