

City of Portland, Maine - Building or Use Permit Application
 389 Congress Street, 04101 Tel: (207) 874-8703, Fax: (207) 874-8716

PERMIT ISSUED

Permit No: 01-085	Issue Date: Jul 24 2001	CBL: 021 E018001
----------------------	----------------------------	---------------------

Location of Construction: 273 Congress St	Owner Name: East End Studios Llc	Owner Address: 273 Congress St 04101	Phone: 207-775-5004
Business Name: n/a	Contractor Name: Maine Bay Canvas	Contractor Address: 53 Industrial Way Portland	Phone: 2078788888
Lessee/Buyer's Name: n/a	Phone: n/a	Permit Type: Awnings	Zone: B2b

Past Use: Commercial / Studio	Proposed Use: Same: Erect a 39' X 3' Awning.	Permit Fee: \$42.00	Cost of Work: \$2,200.00	CEO District: 1
---	--	-------------------------------	------------------------------------	---------------------------

FIRE DEPT: <input type="checkbox"/> Approved <input type="checkbox"/> Denied	INSPECTION: Use Group: 1 Type:
---	---

Signature: *[Signature]*

Proposed Project Description:
Erect a 39' X 3' Awning.

PEDESTRIAN ACTIVITIES DISTRICT (P.A.D.)

Action: Approved Approved w/Conditions Denied

Signature: _____ **Date:** _____

Permit Taken By: cjh	Date Applied For: 07/12/2001	Zoning Approval
--------------------------------	--	------------------------

1. This permit application does not preclude the Applicant(s) from meeting applicable State and Federal Rules. 2. Building permits do not include plumbing, septic or electrical work. 3. Building permits are void if work is not started within six (6) months of the date of issuance. False information may invalidate a building permit and stop all work..	Special Zone or Reviews <input type="checkbox"/> Shoreland <input type="checkbox"/> Wetland <input type="checkbox"/> Flood Zone <input type="checkbox"/> Subdivision <input type="checkbox"/> Site Plan Maj <input type="checkbox"/> Minor <input type="checkbox"/> MM <input type="checkbox"/> Date: <i>7/23/01</i>	Zoning Appeal <input type="checkbox"/> Variance <input type="checkbox"/> Miscellaneous <input type="checkbox"/> Conditional Use <input type="checkbox"/> Interpretation <input type="checkbox"/> Approved <input type="checkbox"/> Denied Date: _____	Historic Preservation <input checked="" type="checkbox"/> Not in District or Landmark <input type="checkbox"/> Does Not Require Review <input type="checkbox"/> Requires Review <input type="checkbox"/> Approved <input type="checkbox"/> Approved w/Conditions <input type="checkbox"/> Denied Date: <i>[Signature]</i>
--	--	---	---

PERMIT ISSUED WITH REQUIREMENTS

CERTIFICATION

I hereby certify that I am the owner of record of the named property, or that the proposed work is authorized by the owner of record and that I have been authorized by the owner to make this application as his authorized agent and I agree to conform to all applicable laws of this jurisdiction. In addition, if a permit for work described in the application is issued, I certify that the code official's authorized representative shall have the authority to enter all areas covered by such permit at any reasonable hour to enforce the provision of the code(s) applicable to such permit.

SIGNATURE OF APPLICANT	ADDRESS	DATE	PHONE
RESPONSIBLE PERSON IN CHARGE OF WORK, TITLE		DATE	PHONE

SIGNAGE PRE-APPLICATION

PLEASE ANSWER ALL QUESTIONS

ADDRESS: 273 CONGRESS ST. PORTLAND ZONE: B-2

OWNER: SHERWOOD HAMILL

APPLICANT: " "

ASSESSOR NO. _____

SINGLE TENANT LOT? YES ___ NO ___

MULTI TENANT LOT? YES ___ NO ___

FREESTANDING SIGN? YES ___ NO ___ DIMENSIONS _____

(ex. pole sign. . .)

MORE THAN ONE SIGN? YES ___ NO ___ DIMENSIONS _____

BLDG. WALL SIGN? YES ___ NO ___ DIMENSIONS _____

(attached to bldg)

MORE THAN ONE SIGN? YES ___ NO ___ DIMENSIONS _____

LIST ALL EXISTING SIGNAGE AND THEIR DIMENSIONS: _____

LOT FRONTAGE (FEET): _____

BLDG FRONTAGE (FEET): _____

AWNING YES NO ___ IS AWNING BACKLIT? YES ___ NO

HEIGHT OF AWNING: 9'

IS THERE ANY COMMUNICATION, MESSAGE, TRADEMARK OR SYMBOL ON IT? NO

*** TENANT BLDG. FRONTAGE (IN FEET) 45' x 1.5 = 67.5

*** REQUIRED INFORMATION

Handwritten notes: $39' \times .833' = 32.487'$ and a signature.

AREA FOR COMPUTATION

A SITE SKETCH AND BUILDING SKETCH SHOWING EXACTLY WHERE EXISTING AND NEW SIGNAGE IS LOCATED MUST BE PROVIDED. SKETCHES AND/OR PICTURES OF PROPOSED ARE ALSO REQUIRED.

SIGNATURE OF APPLICANT: S. Hamill DATE: 7-11-01

THIS IS NOT A PERMIT/CONSTRUCTION CANNOT COMMENCE UNTIL THE PERMIT IS ISSUED

**Sign Permit Pre-Application
Attached Single Family Dwellings/Two-Family Dwelling
Multi-Family or Commercial Structures and Additions Thereto**

In the interest of processing your application in the quickest possible manner, please complete the Information below for a Building or Use Permit.

NOTEIf you or the property owner owes real estate or personal property taxes or user charges on ANY PROPERTY within the City, payment arrangements must be made before permits of any kind are accepted.**

Location/Address of Construction (include Portion of Building): 273 CONGRESS ST. PORTLAND, ME

Total Square Footage of Proposed Structure	Square Footage of Lot
--	-----------------------

Tax Assessor's Chart, Block & Lot Number Chart# 21 Block# E Lot# 18	Owner: SHERWOOD HAMILL	Telephone#: 775-5004 * <i>call when rec'd</i>
---	----------------------------------	---

Owner's Address: 2 ATLANTIC ST. PORTLAND	Lessee/Buyer's Name (If Applicable)	Total Sq. Ft. of Sign 2200	Fee \$ 42.⁰⁰
--	-------------------------------------	--------------------------------------	-----------------------------------

Proposed Project Description:(Please be as specific as possible) AWNING

Contractor's Name, Address & Telephone MAINE BAY CANVAS	Rec'd By
---	----------

Current Use: RETAIL	Proposed Use: RETAIL
----------------------------	-----------------------------

Signature of applicant: <i>S. Hamill</i>	Date: 7-12-01
--	----------------------

Signage Permit Fee: \$30.00 plus .20 per square foot of signage

7/13 CH

BUILDING PERMIT REPORT

DATE: 16 July 2001 ADDRESS: 273 Congress ST. CBL: 021-E-018

REASON FOR PERMIT: To erect a 3'x39' awning

BUILDING OWNER: East End Studios LLC

PERMIT APPLICANT: _____ /CONTRACTOR Maine Bay Carves.

USE GROUP: _____ CONSTRUCTION TYPE: _____ CONSTRUCTION COST: \$2200. PERMIT FEES: \$42.00

The City's Adopted Building Code (The BOCA National Building Code/1999 with City Amendments)
The City's Adopted Mechanical Code (The BOCA National Mechanical Code/1993)

CONDITION(S) OF APPROVAL

This permit is being issued with the understanding that the following conditions shall be met: *1

- X 1. This permit does not excuse the applicant from meeting applicable State and Federal rules and laws.
- 2. Before concrete for foundation is placed, approvals from the Development Review Coordinator and Inspection Services must be obtained. (A 24 hour notice is required prior to inspection) **"ALL LOT LINES SHALL BE CLEARLY MARKED BEFORE CALLING."**
- 3. Foundation drain shall be placed around the perimeter of a foundation that consists of gravel or crushed stone containing not more than 10 percent material that passes through a No. 4 sieve. The drain shall extend a minimum of 12 inches beyond the outside edge of the footing. The thickness shall be such that the bottom of the drain is not higher than the bottom of the base under the floor, and that the top of the drain is not less than 6 inches above the top of the footing. The top of the drain shall be covered with an approved filter membrane material. Where a drain tile or perforated pipe is used, the invert of the pipe or tile shall not be higher than the floor elevation. The top of joints or top of perforations shall be protected with an approved filter membrane material. The pipe or tile shall be placed on not less than 2" of gravel or crushed stone, and shall be covered with not less than 6" of the same material. Section 1813.5.2
- 4. Foundations anchors shall be a minimum of 1/2" in diameter, 7" into the foundation wall, minimum of 12" from corners of foundation and a maximum 6' O.C. between bolts. Section 2305.17
- 5. Waterproofing and dampproofing shall be done in accordance with Section 1813.0 of the building code.
- 6. Precaution must be taken to protect concrete and masonry. Concrete Sections 1908.9-19.8.10/ Masonry Sections 2111.3-2111.4.
- 7. It is strongly recommended that a registered land surveyor check all foundation forms before concrete is placed. This is done to verify that the proper setbacks are maintained.
- 8. Private garages located beneath habitable rooms in occupancies in Use Group R-1, R-2, R-3 or I-1 shall be separated from adjacent interior spaces by fire partitions and floor/ceiling assembly which are constructed with not less than 1-hour fire resisting rating. Private garages attached side-by-side to rooms in the above occupancies shall be completely separated from the interior spaces and the attic area by means of 1/2 inch gypsum board or the equivalent applied to the garage side. (Chapter 4, Section 407.0 of the BOCA/1999)
- 9. All chimneys and vents shall be installed and maintained as per Chapter 12 of the City's Mechanical Code. (The BOCA National Mechanical Code/1993). Chapter 12 & NFPA 211
- 10. Sound transmission control in residential building shall be done in accordance with Chapter 12, Section 1214.0 of the City's Building Code.
- 11. Guardrails & Handrails: A guardrail system is a system of building components located near the open sides of elevated walking surfaces for the purpose of minimizing the possibility of an accidental fall from the walking surface to the lower level. Minimum height all Use Groups 42". In occupancies in Use Group A, B,H-4, I-1, I-2, M, R, public garages and open parking structures, open guards shall have balusters or be of solid material such that a sphere with a diameter of 4" cannot pass through any opening. Guards shall not have an ornamental pattern that would provide a ladder effect. Handrails shall be a minimum of 34" but not more than 38". Exception: Handrails that form part of a guard shall have a height not less than 36 inches (914 mm) and not more than 42 inches (1067 mm). Handrail grip size shall have a circular cross section with an outside diameter of at least 1 1/4" and not greater than 2". (Sections 1021 & 1022.0). Handrails shall be on both sides of stairway. (Section 1014.7) **R-3 (ONE & TWO FAMILY DWELLINGS) GUARD HEIGHT IS 36" MINIMUM.**
- 12. Headroom in habitable space is a minimum of 7'6". (Section 1204.0)
- 13. Stair construction in Use Group R-3 & R-4 is a minimum of 10" tread and 7 1/2" maximum rise. All other Use Group minimum 11" tread, 7" maximum rise. (Section 1014.0)
- 14. The minimum headroom in all parts of a stairway shall not be less than 80 inches. (6'8") 1014.4
- 15. The Minimum required width of a corridor shall be determined by the most restrictive of the criteria under section 1011.3 but not less than 36".
- 16. Every sleeping room below the fourth story in buildings of Use Groups R and I-1 shall have at least one operable window or exterior door approved for emergency egress or rescue. The units must be operable from the inside without the use of special knowledge or separate tools. Where windows are provided as means of egress or rescue they shall have a sill height not more than 44 inches (1118mm) above the floor. All egress or rescue windows from sleeping rooms shall have a minimum net clear opening height dimension of 24 inches (610mm). The minimum net clear opening width dimension shall be 20 inches (508)mm, and a minimum net clear opening of 5.7 sq. ft. (Section 1010.4)
- 17. Each apartment shall have access to two (2) separate, remote and approved means of egress. A single exit is acceptable when it exits directly from the apartment to the building exterior with no communications to other apartment units. (Section 1010.1)
- 18. All vertical openings shall be enclosed with construction having a fire rating of at least one (1) hour, including fire doors with self closure's. (Over 3 stories in height requirements for fire rating is two (2) hours. (Section 710.0)
- 19. The boiler shall be protected by enclosing with (1) hour fire rated construction including fire doors and ceiling, or by providing automatic extinguishment. (Table 302.1.1)

7/12

20. All single and multiple station smoke detectors shall be of an approved type and shall be installed in accordance with the provisions of the City's Building Code Chapter 9, Section 920.3.2 (BOCA National Building Code/1999), and NFPA 101 Chapter 18 & 19. (Smoke detectors shall be installed and maintained at the following locations):
 - In the immediate vicinity of bedrooms
 - In all bedrooms
 - In each story within a dwelling unit, including basements
21. A portable fire extinguisher shall be located as per NFPA #10. They shall bear the label of an approved agency and be of an approved type. (Section 921.0)
22. The Fire Alarm System shall be installed and maintained to NFPA #72 Standard.
23. The Sprinkler System shall be installed and maintained to NFPA #13 Standard.
24. All exit signs, lights and means of egress lighting shall be done in accordance with Chapter 10 Section & Subsections 1023.0 & 1024.0 of the City's Building Code. (The BOCA National Building Code/1999)
25. Section 25 - 135 of the Municipal Code for the City of Portland states, "No person or utility shall be granted a permit to excavate or open any street or sidewalk from the time of November 15 of each year to April 15 of the following year".
26. The builder of a facility to which Section 4594-C of the Maine State Human Rights Act Title 5 MRSA refers, shall obtain a certification from a design professional that the plans commencing construction of the facility, the builder shall submit the certification the Division of Inspection Services.
27. Ventilation and access shall meet the requirements of Chapter 12 Sections 1210.0 and 1211.0 of the City's Building Code. (Crawl spaces & attics).
28. All electrical, plumbing and HVAC permits must be obtained by Master Licensed holders of their trade. No closing in of walls until all electrical (min. 72 hours notice) and plumbing inspections have been done.
29. All requirements must be met before a final Certificate of Occupancy is issued.
30. All building elements shall meet the fastening schedule as per Table 2305.2 of the City's Building Code (The BOCA National Building Code/1996).
31. Ventilation of spaces within a building shall be done in accordance with the City's Mechanical code (The BOCA National Mechanical Code/1993). (Chapter M-16)
32. Please read and implement the attached Land Use Zoning report requirements.
33. Boring, cutting and notching shall be done in accordance with Sections 2305.3, 2305.3.1, 2305.4.4 and 2305.5.1 of the City's Building Code.
34. Bridging shall comply with Section 2305.16.
35. Glass and glazing shall meet the requirements of Chapter 24 of the building code. (Safety Glazing Section 2406.0)
36. All flashing shall comply with Section 1406.3.10.
37. All signage shall be done in accordance with Section 3102.0 signs of the City's Building Code, (The BOCA National Building Code/1999).

* 38. All drawings shall comply with section 3105.0. (see attached)

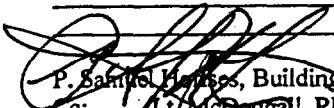
 P. Samuel Harris, Building Inspector
 Cc: Lt. McDougall, PFD
 Marge Schumuckal, Zoning Administrator
 Michael Nugent, Inspection Service Manager

PSH 10/1/00

****This permit is herewith issued, on the basis of plans submitted and conditions placed on these plans, any deviations shall require a separate approval**

*****THIS PERMIT HAS BEEN ISSUED WITH THE UNDERSTANDING THAT ALL THE CONDITIONS OF THE APPROVAL SHALL BE COMPLETED. THEREFORE, BEFORE THE WORK IS COMPLETED A REVISED PLAN OR STATEMENT FROM THE PERMIT HOLDER SHALL BE SUBMITTED TO THIS OFFICE SHOWING OR EXPLAINING THAT THE CONDITIONS HAVE BEEN MET. IF THIS REQUIREMENT IS NOT RECEIVED YOUR CERTIFICATE OF OCCUPANCY SHALL BE WITHHELD. (You Shall Call for Inspections)**

******ALL PLANS THAT REQUIRE A PROFESSIONAL DESIGNER'S SEAL, (AS PER SECTION 114.0 OF THE BUILDING CODE) SHALL ALSO BE PRESENTED TO THIS DIVISION ON AUTO CAD LT. 2000, DXF FORMAT OR EQUIVALENT.**

*******CERTIFICATE OF OCCUPANCY FEE \$50.00**

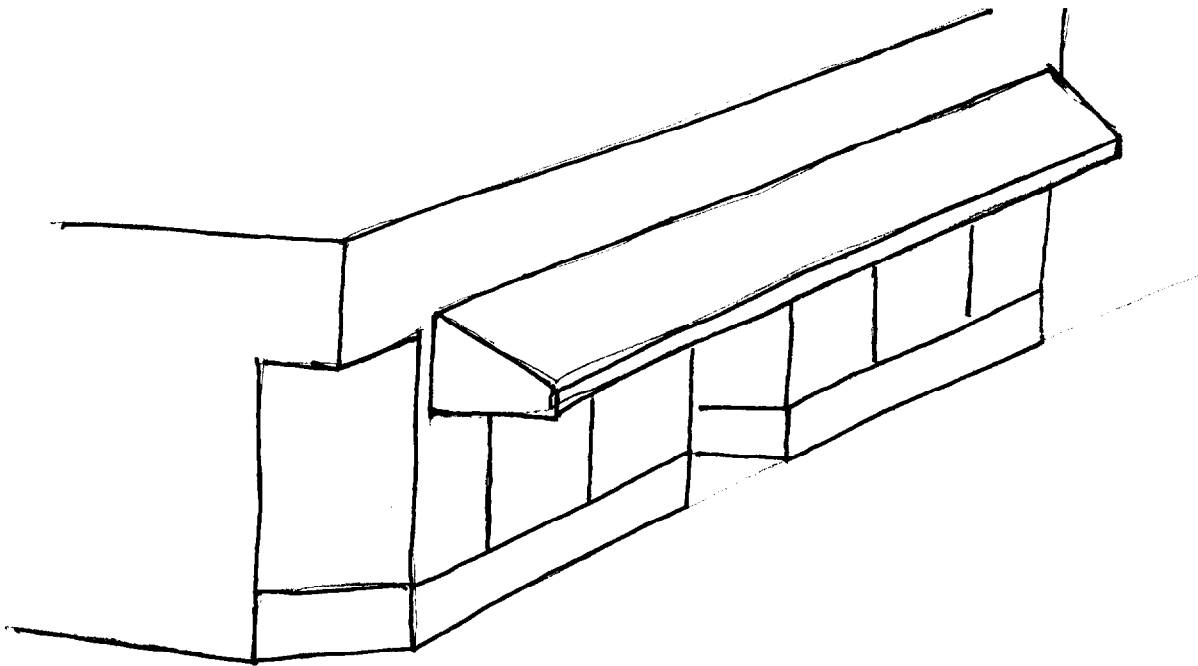

AWNING 273 CONGRESS ST. 7-13-01

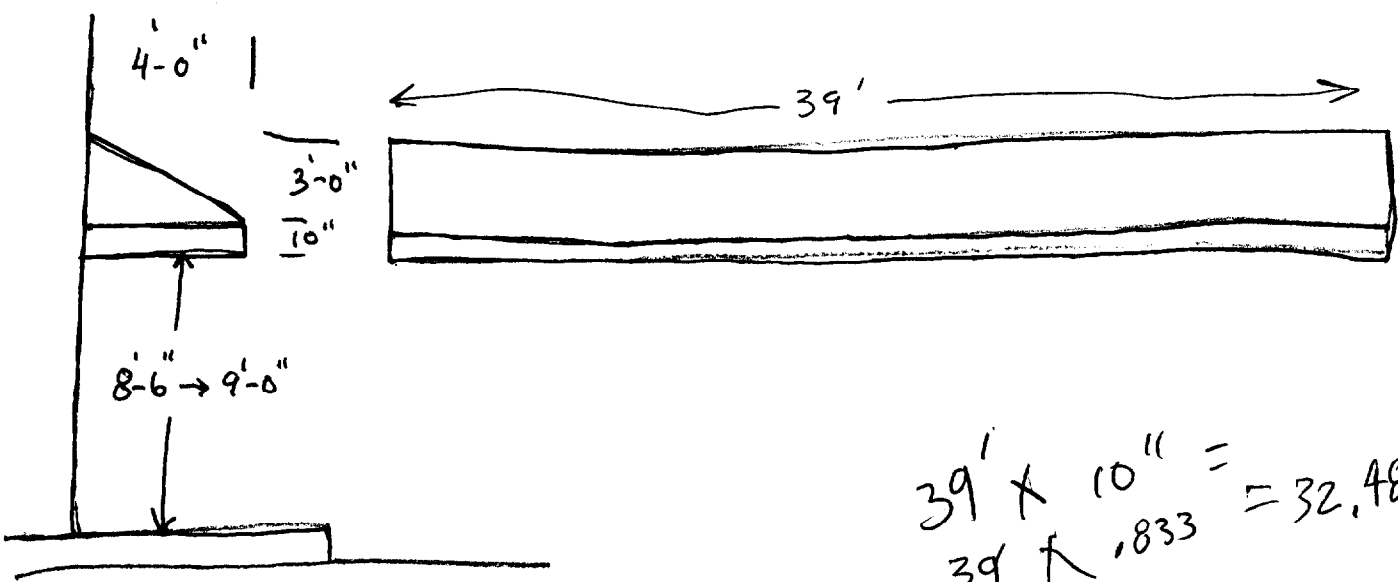

$$39' \times 10'' = 32.487$$
$$39 \times .833 = 32.487$$

Certificate of Flame Resistance



REGISTERED
APPLICATION
CONCERN No.

FA-36801

ISSUED BY

Glen Raven Mills, Inc.
1831 N. Park Avenue
Glen Raven, NC 27217

(Phone) 910/227-6211 (Fax) 910/229-4039

Date treated or
manufactured

This is to certify that the materials described on the reverse side hereof have been flame-retardant treated (or are inherently nonflammable).

FOR EAST END STUDIOS ADDRESS 273 CONGRESS ST.
CITY PORTLAND STATE ME

Certification is hereby made that: (Check "a" or "b")

(a) The articles described on the reverse side of this Certificate have been treated with a flame-retardant chemical approved and registered by the State Fire Marshal and that the application of said chemical was done in conformance with the laws of the State of California and the Rules and Regulations of the State Fire Marshal.

Name of chemical used _____ Chem. Reg. No. _____

Method of application _____

(b) The articles described on the reverse side hereof are made from a flame-resistant fabric or material registered and approved by the State Fire Marshal for such use.

Trade name of flame-resistant fabric or material used FR Sunbrella® Reg. No. FA-36801

The Flame Retardant Process Used will not **Be Removed By Washing**
(will or will not)

GLEN RAVEN MILLS, INC.

Glen Raven Mills, Inc.

Name of Applicator or Production Superintendent

By

[Signature]
Title