



**SILENT
KNIGHT**

by Honeywell

SK-Heat, SK-Heat-HT and SK-Heat-ROR

Addressable Thermal Heat and Rate-of-Rise Detectors

The SK-Heat, SK-Heat-HT, and SK-Heat-ROR are plug in thermal detectors, with integral communication, that provide features that surpass conventional detectors. These thermal detectors are for use with Silent Knight IntelliKnight series Fire Alarm Control Panels (FACPs).

IntelliKnight heat detectors are an essential component in virtually any IntelliKnight installation. The IntelliKnight panel recognizes each detector by its specific address, so precious seconds are not wasted in determining location of an alarm.

Description

SK-Heat, SK-Heat-HT and SK-Heat-ROR are intelligent sensors that utilize a state-of-the-art thermistor sensing circuit for fast response. Sensitivity is continuously monitored and reported to the FACP. Point ID capability allows each detector's address to be set with rotary address switches, providing exact detector locations for selective maintenance when chamber contamination reaches unacceptable levels.

SK-Heat is a fixed temperature sensor that uses a thermistor sensing circuit to produce 135°F (57°C) fixed temperature alarm.

SK-Heat-HT is a variable high temperature detector that provides high temperature detection at 135°F - 190°F. (57°C - 88°C)

SK-Heat-ROR is a rate-of-rise temperature sensor with 135°F (57°C) fixed temperature alarm.

Features

- Reliable analog communications for trouble-free operation
- Age resistant polymer housing
- Innovative thermistor sensing circuit
- Superior EMI resistance for reliability
- Variety of mounting options to meet any application
- Dual LED indicators for 360° visibility

- Detector transmits signal to indicate maintenance is required
- Plug-in mounting provides ease of installation
- Optional remote LED annunciator (System Sensor® PN RA100Z)
- Tamper-proof feature available on mounting bases
- Rotary address switches for fast installation
- UL Listed

Specifications

Physical

Height: 2.0" (51 mm)
Diameter: 6.1" (155 mm) installed in B210LP base
Shipping Weight: 4.8 oz (137 g)

Electrical

Operating Voltage:
15 to 32 Volts DC Peak
Standby Current:
300µA @ 24 VDC
LED Current: 6.5 mA@ 24 VDC

Environmental

Operating Temperature

SK-Heat & SK-Heat-ROR:
-4° - 100°F (-20°C - 38°C)

SK-Heat-HT: -4° - 150°F
(-20°C - 66°C)

Humidity: 10% - 93%
noncondensing

Thermal Ratings

SK-Heat: Fixed temperature alarm
135°F (57°C)

SK-Heat-HT: High temperature heat sensor 135°F - 190°F (57°C - 88°C)



SK-Heat (base included)

SK-Heat-ROR: Rate-of-rise detection 15°F/min (8.3°C/min)

Compatibility

The SK-Heat, SK-Heat-HT and SK-Heat-ROR are compatible with the following detector bases:

B210LP	6" base (included)
B501	2 wire base
B224BI	Isolator base
B224RB	Relay base
B200SR	Sounder base

The SK-Heat-HT and SK-Heat-ROR are compatible with the following IntelliKnight FACP's:

5820XL
5820XL-EVS
5808
5700

The SK-Heat is compatible with the following IntelliKnight FACP's:

5820XL
5820XL-EVS
5808
5700
5600 (Rev 2.0 or higher)

Model SK-Heat, SK-Heat-HT, SK-Heat ROR Addressable Thermal and Rate-of-Rise Thermal Detectors

Engineering Specifications

The contractor shall furnish and install where indicated on the plans, Intelligent Thermal Sensor Silent Knight Model SK-Heat, SK-Heat-HT or SK-Heat-ROR. The base included shall be B210LP.

The Heat detector shall have a flashing status LED for visual supervision. When the detector is activated, the flashing LED will latch on steady at full brilliance. The detector may be reset by actuating the control panel reset switch.

The vandal-resistant, security locking feature shall be used in those areas as indicated on the drawing. The locking feature shall be field removable when not required. Voltage and RF/transient suppression techniques shall be employed to minimize false alarm potential.

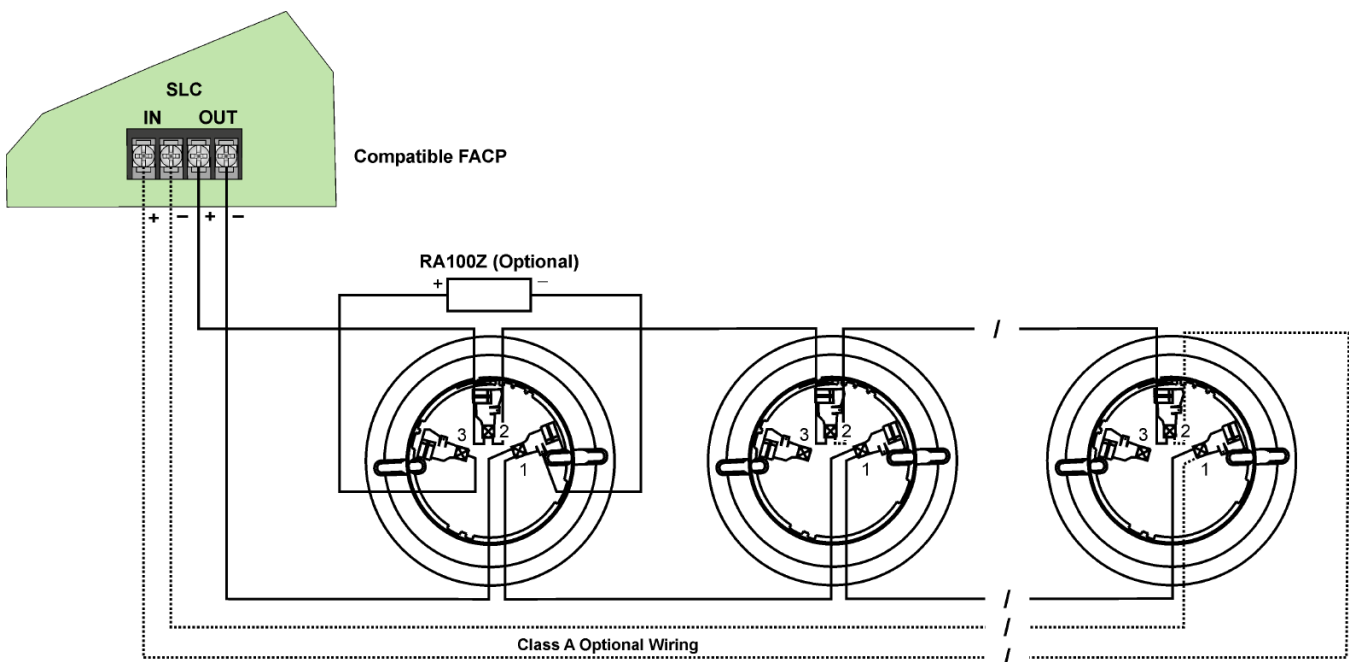

Wiring SK-Series Detector Mounting Bases

Accessories

RA100Z - Remote LED Annunciator.

RMK400 - Recessed Mounting Kit. Provides low profile for use with B501.

XR2B - Detector Removal Tool. A removal and re- placement tool for SK plug-in detectors. Includes the T55-127-000.

M02-04-01 - Replacement Test Magnet.

M02-09-00 - Test Magnet with Telescoping Handle.

XP-4 - Extension Pole for XR2B. Extends from 5 – 15 ft.

T55-127-000 - Detector Removal Head.

BCK-200B - Black Detector Kit. For SK-series detectors.

* Unless otherwise noted, specifications apply to all SK thermal detectors.



**SILENT
KNIGHT**

by Honeywell

This document is not intended to be used for installation purposes. We try to keep our product information up-to-date and accurate. We cannot cover all specific applications or anticipate all requirements. All specifications are subject to change without notice. For more information, contact Silent Knight 12 Clintonville Road Northford, CT 06472-1610 Phone: (800) 328-0103, Fax: (203) 484-7118. For Technical Support, Please call 800-446-6444.

www.silentknight.com