

IN	2x4's @ 24" o.c.	7N	2x6's @ 24" o.c.
2N	2x4's @ 24" o.c. + 1-2x4's @ 48" o.c.	8N	2x6's @ 24" o.c. + 1-2x6 @ 48" o.c.
3N	2x4's @ 12" o.c.	9N	2x6's @ 16" o.c.
4N	2x4's @ 12" o.c. + 1-2x4 @ 24" o.c.	10N	2x6's @ 12" o.c.
5N	2-2x4's @ 12" o.c.	11N	2x6's @ 12" o.c. + 1-2x6 @ 24" o.c.
6N	2x4's @ 16" o.c.		

NOTE:
 1. ALL STUDS TO BE SPF NO.1/NO.2 OR BETTER.
 2. ALL NON BEARING PARTITIONS TO BE 2x4's @ 24" o.c. U.N.O.
 3. ALL EXTERIOR WALLS ARE BEARING WALL 9N U.N.O. ON PLAN.
 4. ALL INTERIOR BEARING WALLS ARE 3N UNLESS NOTED ON PLAN.

ROOMS:	LIVE LOAD	TOP CHORD DEAD LOAD	BOTTOM CHORD DEAD LOAD	TOTAL
	40 psf	35 psf	5 psf	80 psf
CORRIDORS:	40 psf	25 psf	10 psf	75 psf
ROOF:	35 psf + allow for drift	15 psf	5 psf	55 psf
PRIVATE ROOF DECK:	40 psf + allow for drift	20 psf	5 psf	65 psf
LOFTS:	30 psf	15 psf	5 psf	50 psf

NOTE:
 TRUSS MFG. TO COORDINATE FLOOR TRUSS FINISHING/MECHANICAL UNITS. MECHANICAL UNIT TO BE CENTERED BETWEEN 2-FLOOR/ROOF TRUSSES.

NOTE:
 ALL NET WALLS TO BE 2x6. WALL PANELIZER TO COORD. ALL NET WALL LOCATIONS WITH ARCHITECT.

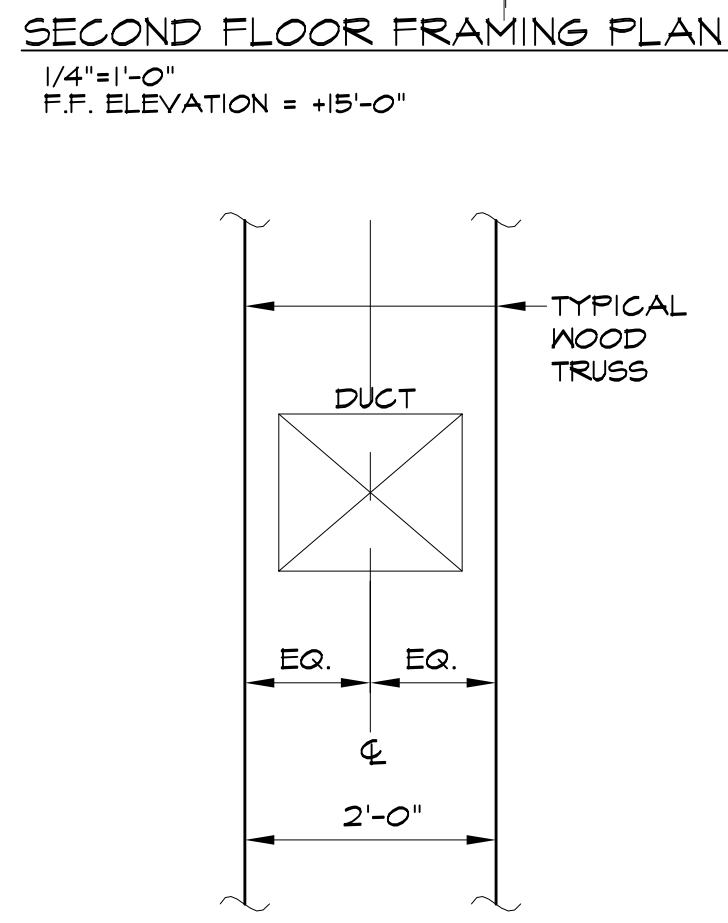

TYPICAL TRUSS LAYOUT @ MECHANICAL UNITS

- FLOOR FRAMING NOTES:**
- FOR TYPICAL DETAILS AND GENERAL NOTES SEE DRAWINGS S2.01 TO S2.03.
 - FOR PLATE HEIGHT, SEE ARCHITECTURAL DRAWINGS.
 - GENERAL CONTRACTOR NOTE: REFER TO ROOF AND FLOOR PLANS FOR LOCATIONS OF POSTS AND JACK STUDS. POSTS AND JACK STUDS SHALL EXTEND DOWN CONTINUOUSLY TO THE FOUNDATION WALL UNLESS INTERRUPTED BY A BEAM OR JACK STUDS. AT ALL JACK STUD AND POST LOCATIONS PROVIDE MATCHING BLOCKING STUDS BELOW FIRST FLOOR SHEATHING DOWN TO FOUNDATION WALL OR LVL BEAMS.
 - FRAMING SUPPLIER SHALL SUBMIT WOOD TRUSS AND LVL HANGER INFORMATION FOR APPROVAL.
 - X-6" LVL INDICATES THE NUMBER OF 1 3/4" x 5 1/2" LVL'S. X-8" LVL INDICATES THE NUMBER OF 1 3/4" x 7 1/2" LVL'S. X-10" LVL INDICATES THE NUMBER OF 1 3/4" x 9 1/2" LVL'S. X-12" LVL INDICATES THE NUMBER OF 1 3/4" x 11 7/8" LVL'S. X-14" LVL INDICATES THE NUMBER OF 1 3/4" x 14" LVL'S. X-16" LVL INDICATES THE NUMBER OF 1 3/4" x 16" LVL'S.
 - "6T" INDICATES GIRDER TRUSS.
 - "R=" INDICATES HANGER LOAD.
 - "KKS" INDICATES THE NUMBER OF FULL HEIGHT KING STUDS.
 - "XJS" INDICATES THE NUMBER OF JACK STUDS.
 - "XXXPSL" INDICATES PARALLAM POST SEE PLAN.
 - "* INDICATES TOP CHORD BEARING TRUSSES.
 - INDICATES FLOOR FRAMING WITH HANGERS OR TOP CHORD BEARING FLUSH FRAMING.
 - INDICATES TRUSSES/JOISTS CONTINUOUS OVER WALLS/HEADERS.
 - INDICATES POINT LOAD ON WOOD TRUSS OR GIRDER TRUSS.
 - ALL HEADERS IN 6" WALLS SHALL BE 2-2x6 UNLESS NOTED OTHERWISE.
 - ALL HEADERS IN 4" WALLS SHALL BE 2-2x10 UNLESS NOTED OTHERWISE.
 - AT 6" WALLS PROVIDE 2 JACK STUDS AT END OF EACH OPENING AND UNDER CONCENTRATED LOAD UNLESS NOTED OTHERWISE. AT 4" WALLS PROVIDE 3 JACK STUDS AT EACH END OF THE OPENING AND UNDER CONCENTRATED LOAD, UNLESS NOTED OTHERWISE.
 - INDICATES 2x... BEARING WALLS BELOW, SEE BEARING WALL SCHEDULE FOR SIZE & SPACING OF WALL STUDS.
 - AT ALL INTERIOR AND EXTERIOR LOAD BEARING WALLS OVER 8'-0" IN HEIGHT, PROVIDE ONE ROW OF WOOD BLOCKING AT MID-HEIGHT OF STUDS.
 - "SWX", "SHEAR WALL" OR INDICATES SHEAR WALL.
 - FOR SHEAR WALL ELEVATIONS AND DETAILS, SEE DRAWING S3 SERIES DWGS.
 - SHEAR WALL ANCHORS SHALL BE PROVIDED AT THE ENDS OF EACH SHEAR WALL. POSITIVE ANCHORAGE SHALL BE CONTINUOUS THROUGH ALL FLOOR LEVELS AND MUST TERMINATE AT FOUNDATIONS. FOR ANCHOR REQUIREMENTS, SEE SHEAR WALL ELEVATION.
 - FOR PIPES HUNG BELOW CORRIDORS, ATTACH PIPE HANGERS AT MID-HEIGHT OF JOISTS.
 - SEE LOAD SCHEDULE FOR FLOOR JOISTS DESIGN LOADS.
 - TRUSS SUPPLIER TO COORDINATE LOCATION AND SIZE OF MECHANICAL CHASES WITH MEP DRAWINGS.
 - PROVIDE POST CAPS AT ALL POST COLUMNS TO SECURE POSTS TO GIRDER TRUSSES OR LVL'S.
 - WHERE TRUSS FALLS DIRECTLY BELOW WATER CLOSET, MOVE TRUSS 6" AND ADD AN ADDITIONAL TRUSS TYP.
 - IN SWN A INDICATES BEARING/SHEAR WALL TYPE. SEE SCHEDULE ON DWG S3 SERIES DWGS. HOLDDOWN SHEAR WALL BEARING WALL.
 - 3-2x12*P.T. INDICATES SOUTHERN PINE GRADE #1 PRESSURE TREATED.
 - INDICATES SEISMIC MOMENT CONNECTION.
 - INDICATES GRAVITY MOMENT CONNECTION.
 - INDICATES SPLICE PLATE CONNECTION W/SHEAR (ASD). FOR DETAILS SEE DRAWING S2.03.

TYPICAL FLOOR CONSTRUCTION
 2x8" STURD-I-FLOOR (24/0) OSB PLACED PERPENDICULAR TO SUPPORTING MEMBERS GLUED & NAILED w/ 8d RING SHANK NAILS AT 10" O.C. TO SUPPORTING MEMBERS AND AT 6" O.C. AT EDGES. EACH STURD-I-FLOOR PANEL SHALL HAVE A 1/8" GAP ALL AROUND.

STATE OF MAINE
 RIMANTAS VEITAS
 No. 5472
 LICENSED PROFESSIONAL ENGINEER

Prepared For: **BATEMAN PARTNERS, LLC.**
 470 FORE STREET
 PORTLAND, ME 04101

Consultant: **VEITAS VEITAS engineers**
 680 Green Street, Suite 101
 Portland, Massachusetts 02104
 TEL: (781) 862-2803 FAX: (781) 862-2805

Architect: **ARCHETYPE architects**
 48 Union Wharf Portland, Maine 04101
 (207) 772-6022 Fax (207) 772-4056

Project: **185 FORE STREET**
 185 Fore Street, Portland Maine

Revisions:
 1 05-22-2015 BID SET
 2 09-22-2015 REVISIONS
 3 11-06-2015 ADDENDUM #3

Date: **16 JUNE, 2014**

Scale:

SECOND FLOOR FRAMING PLAN

S1.02