

**8 | TYPICAL FRENCH BALCONY RAILING ELEVATION**  
1/2" = 1'-0"

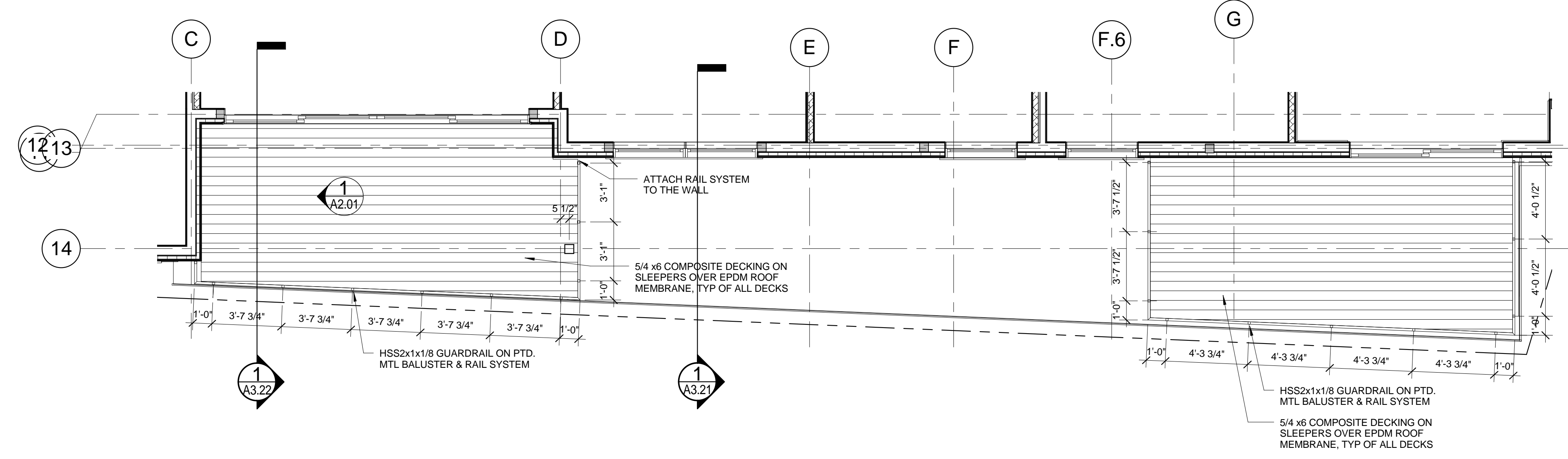

**5 | DECKS AT SECOND FLOOR**  
1/4" = 1'-0"

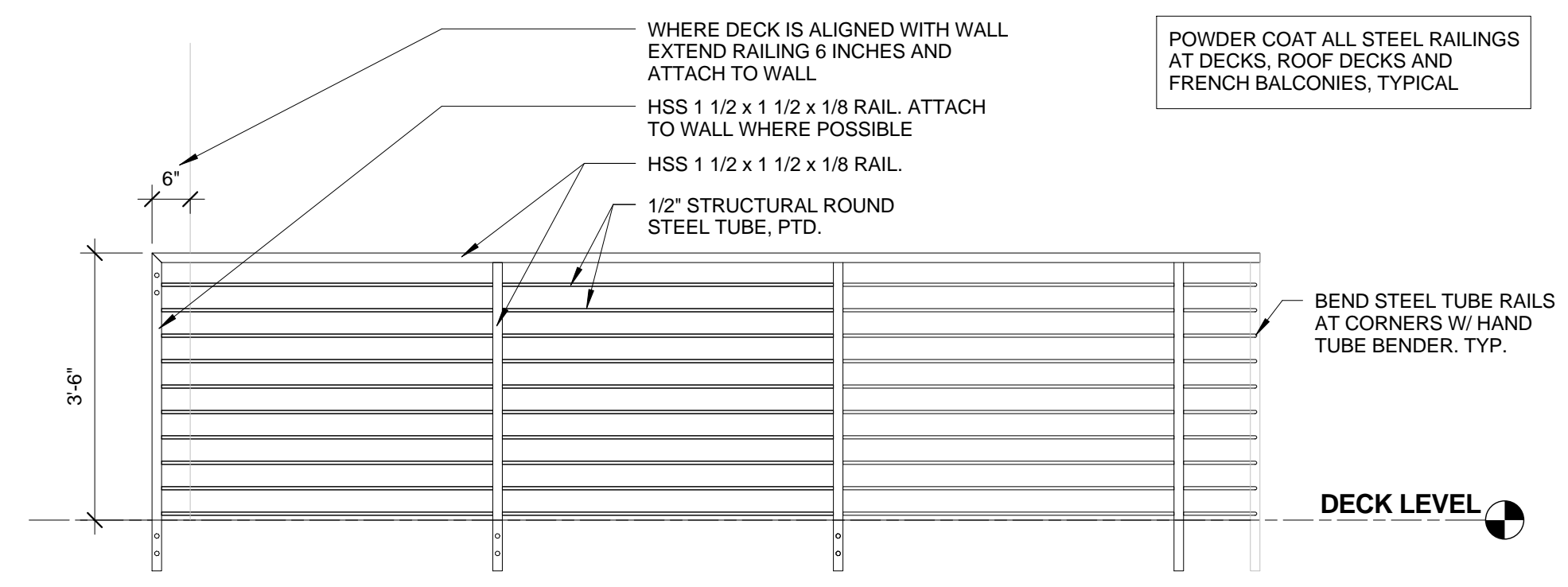

**7 | TYPICAL DECK RAIL ELEVATION**  
1/2" = 1'-0"

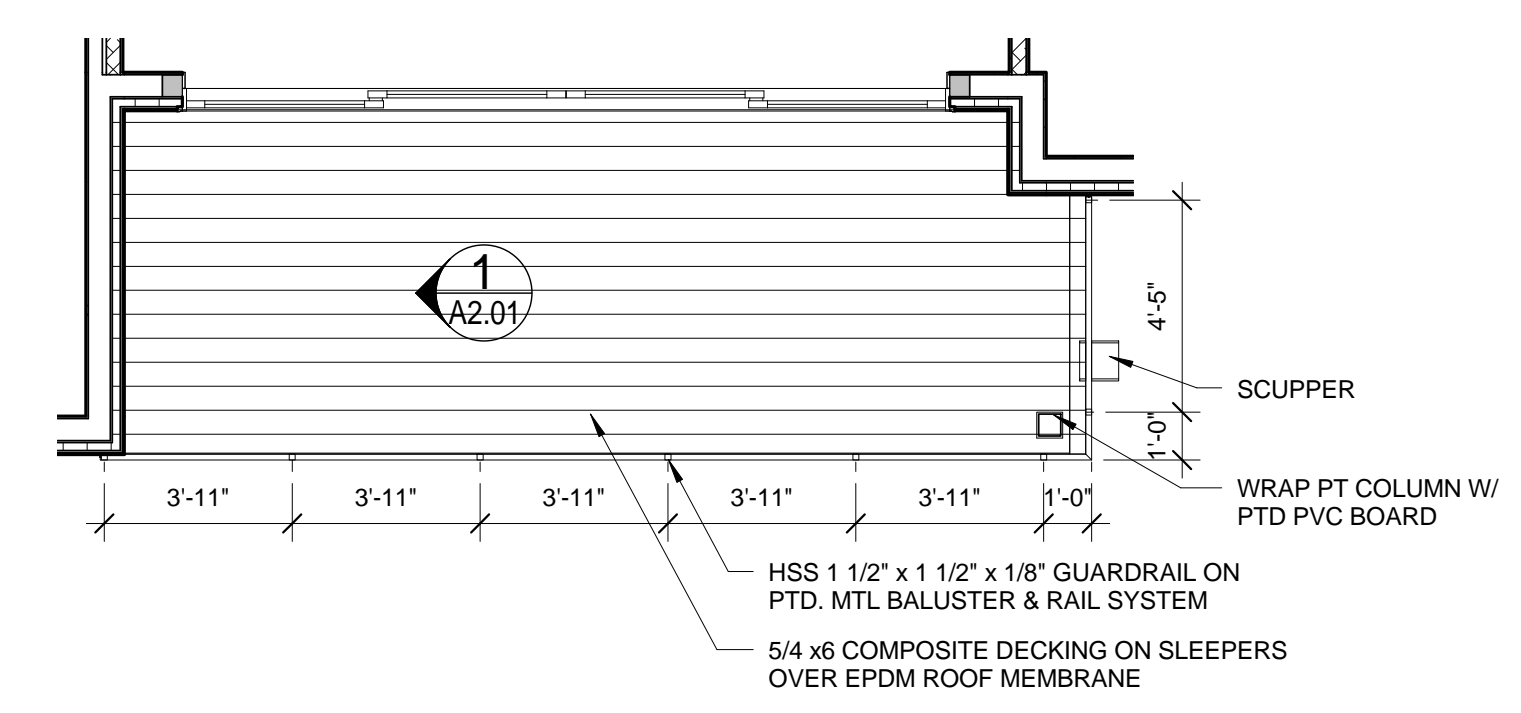

**4 | DECK AT UNIT 302**  
1/4" = 1'-0"

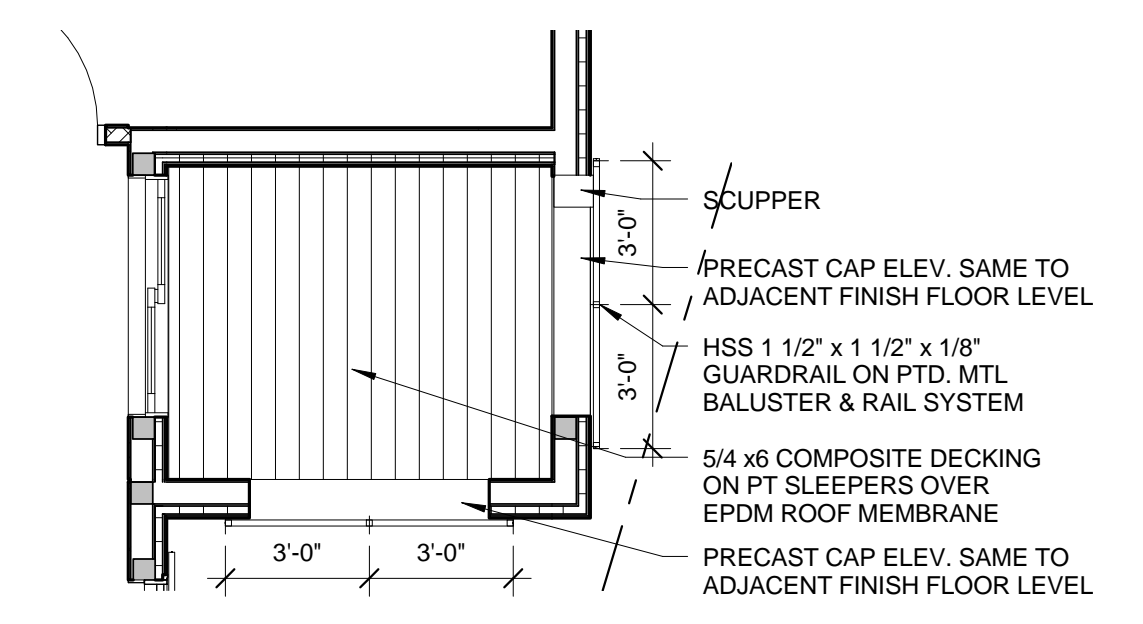

**2. | UNIT 301 DECK**  
1/4" = 1'-0"

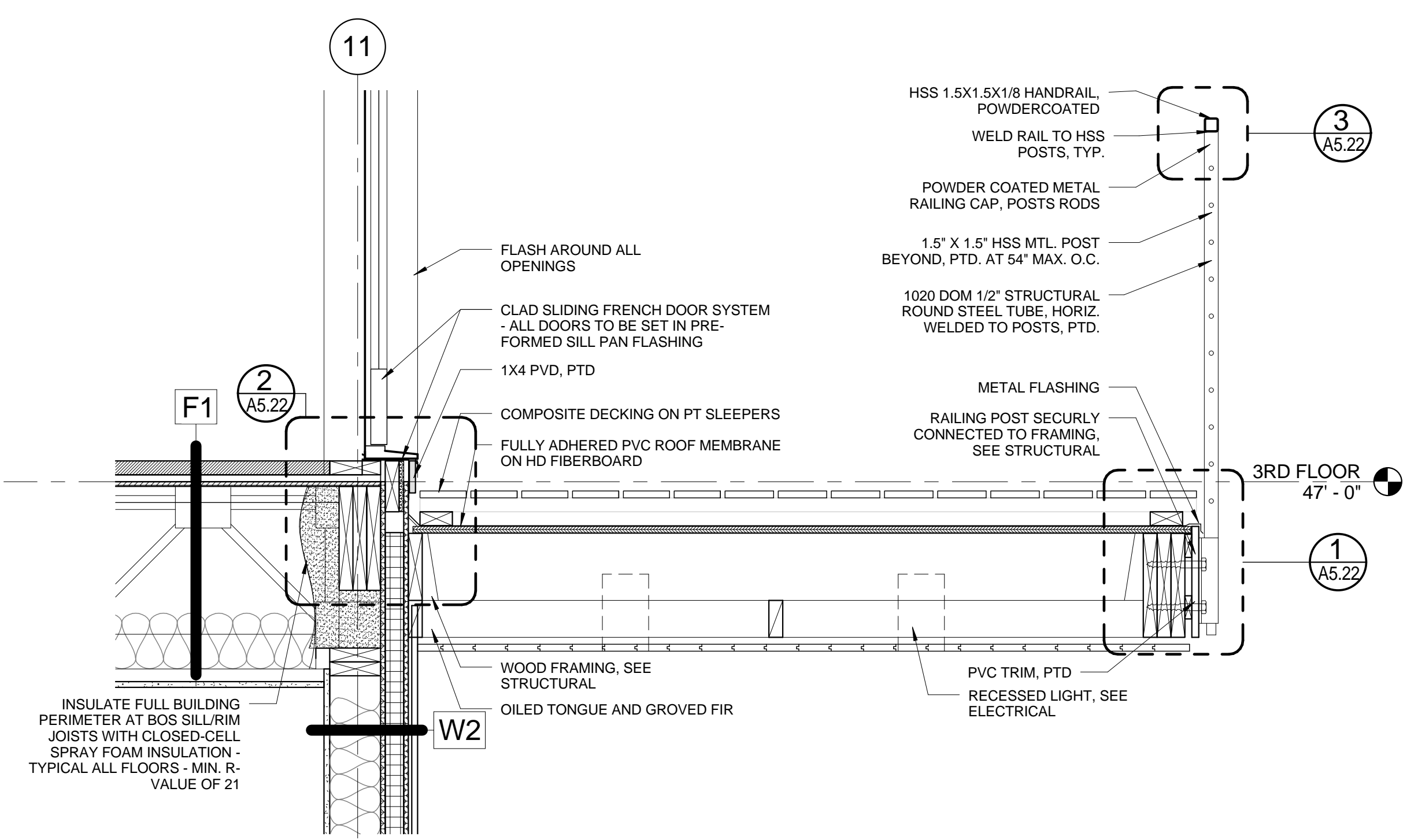

**6 | TYP. DETAIL AT BALCONIES**  
1" = 1'-0"

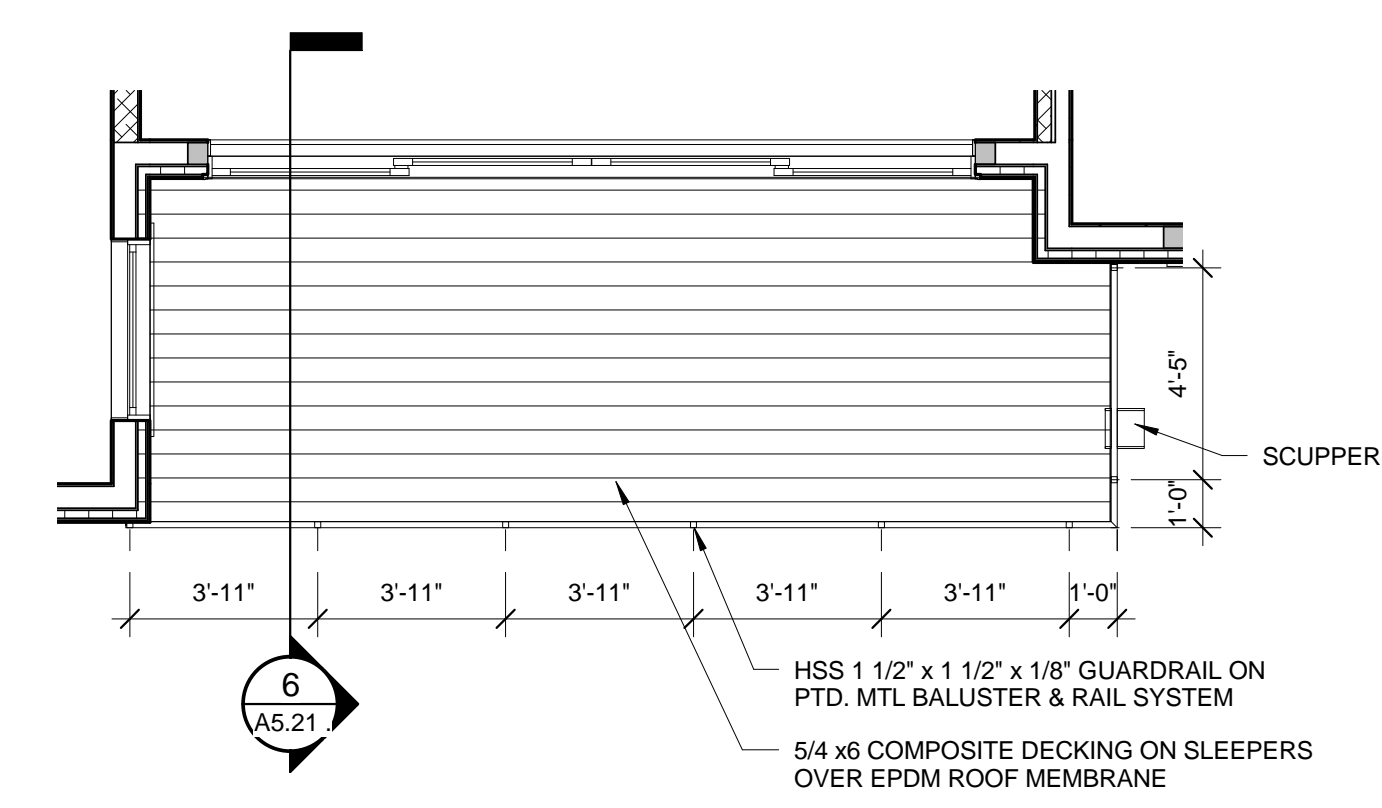

**3 | DECK AT UNIT 402**  
1/4" = 1'-0"

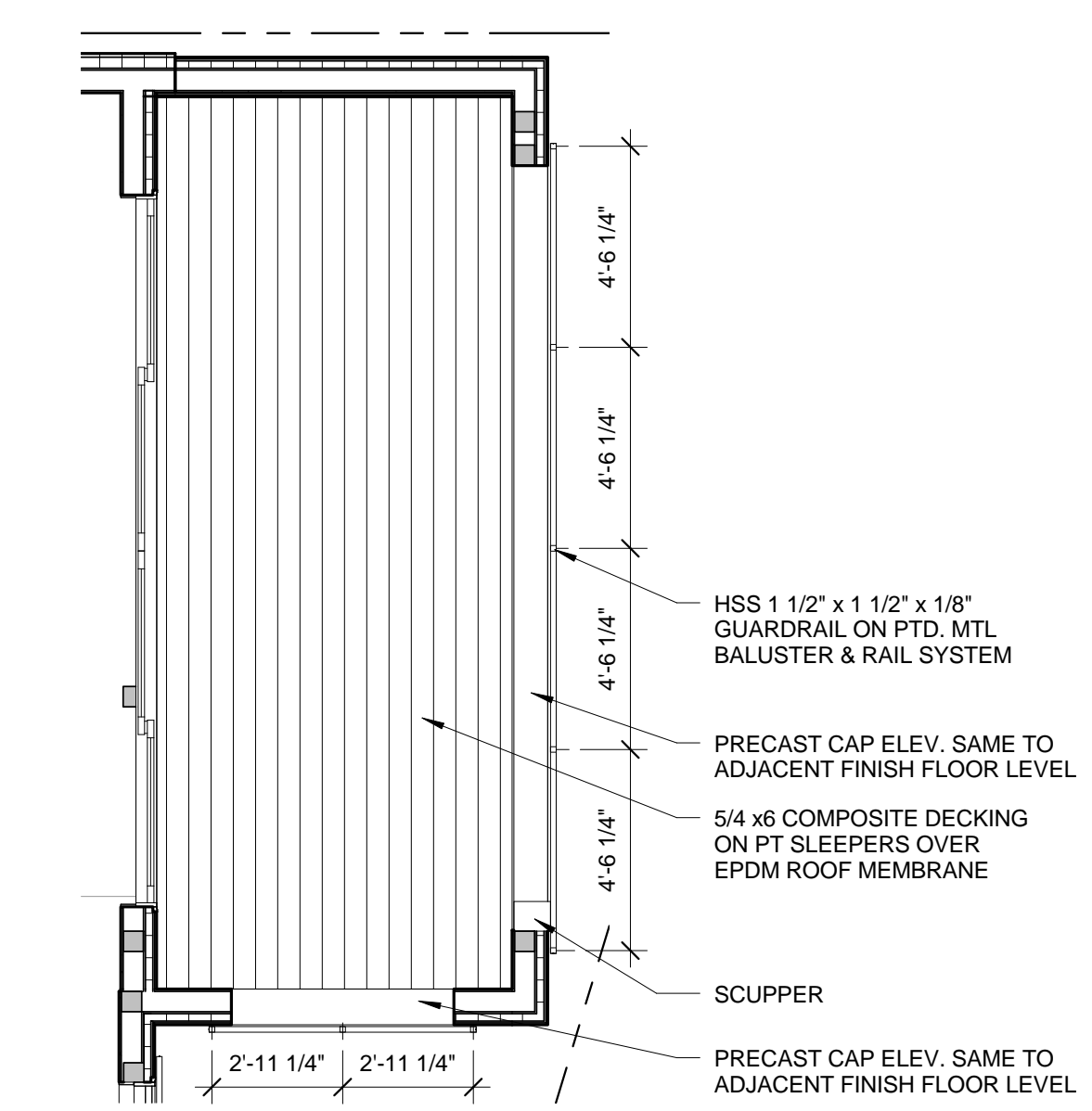

**1. | DECK AT UNIT 401**  
1/4" = 1'-0"