

General Notes
 1. B.J. means "Between Joists".

General Mechanical Notes

1. Kitchen Hood exhaust ductwork shall be constructed of 16 gauge black iron with welded construction per NFPA96. Provide bolted and gasketed cleanout doors as required. Exhaust ductwork shall be wrapped with two (2) layers of 1/2" thick Fibergarap Elite or Unifrax ceramic insulation, suitable for zero clearance to combustibles.
2. Gas water heater venting shall be Centritherm, or equal polypropylene.
3. Provide combination fire / smoke dampers (FD / SD) at all locations where the ducts penetrate the shaft wall enclosure for ducts that penetrate two (2) or more floors (except grease ducts). For ducts that only penetrate one (1) floor, fire dampers are required.
4. Concealed supply ductwork shall be insulated with 2" thick fiberglass ductwrap w/ FSK.
5. Domestic hot and cold water piping shall be insulated with 1" thick fiberglass pipe insulation.
6. Coordinate exposed ductwork with the lighting plan.

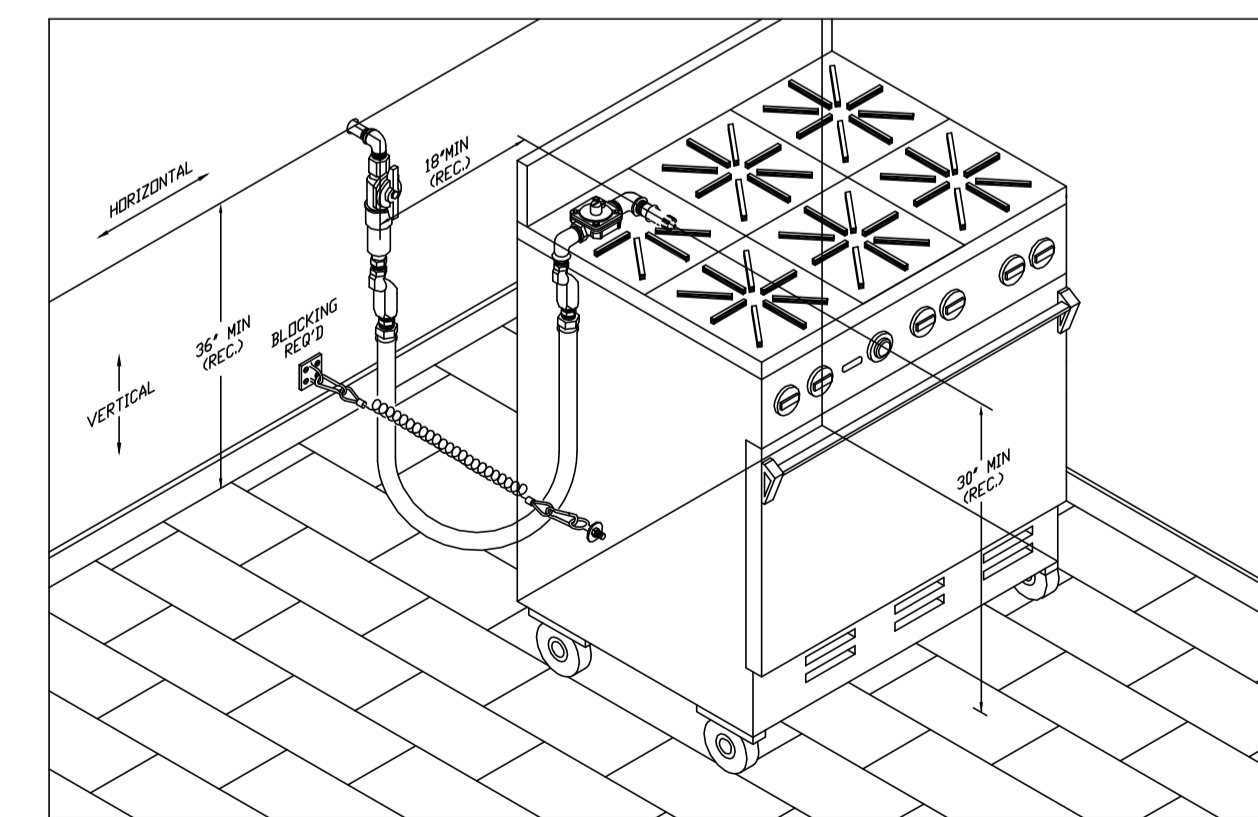

Gas Hose Connection Detail @ Kitchen Appliances
 SCALE None

Prepared For:	Archetype Union Wharf Portland, ME 04101
Consultant:	
Architect:	
Project:	16 MIDDLE STREET OFFICE BUILDING MIDDLE STREET PORTLAND, MAINE
Revisions:	
Date:	13 APR 2017
Scale:	1/8" = 1'-0" U.N.O.
BenKay Restaurant HVAC 1st FLOOR PLAN	
M1.02	