

1 TILSON 3RD FLOOR FIT UP PLAN
1/8" = 1'-0"

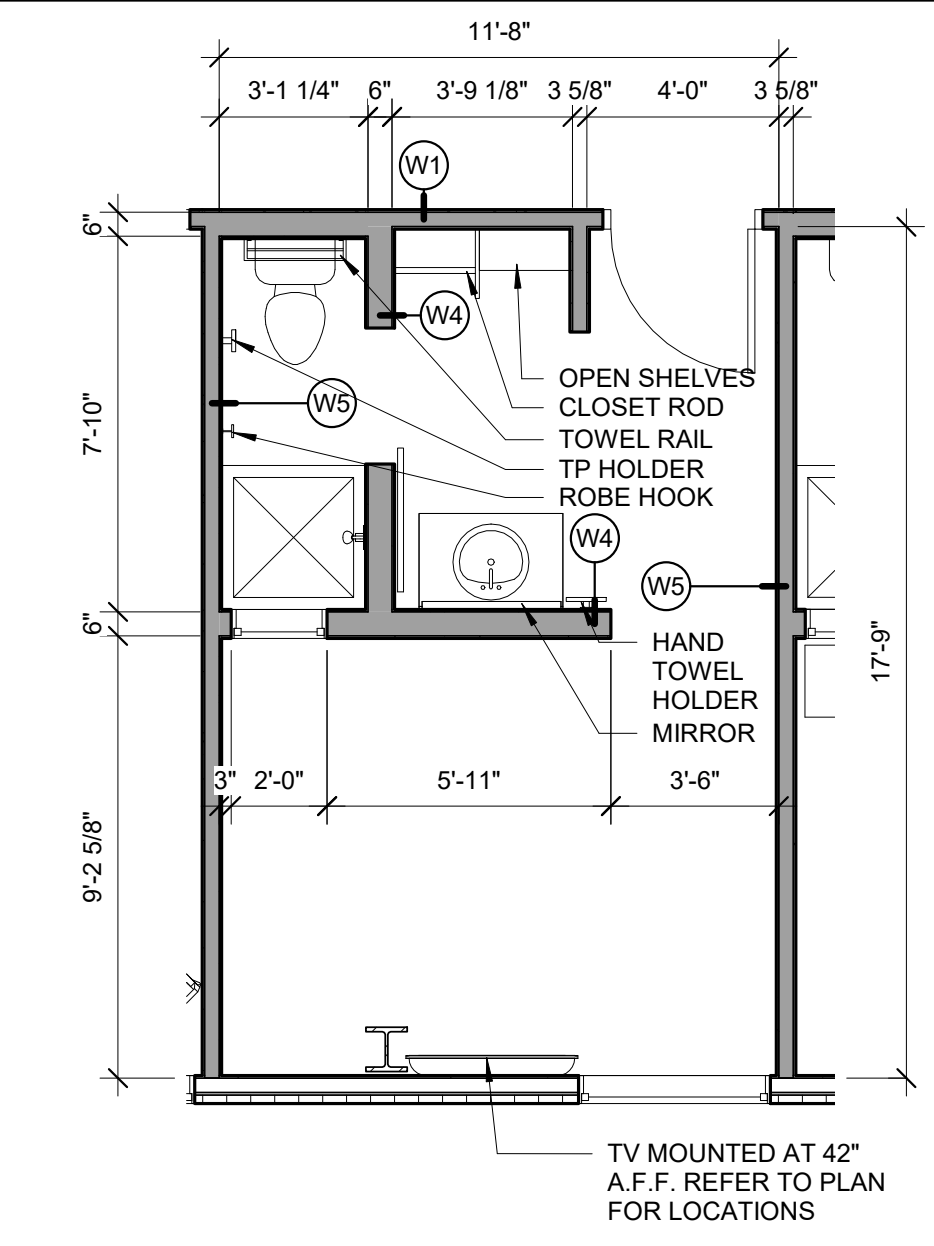

2 TYPICAL GUEST ROOM ENLARGED PLAN
1/4" = 1'-0"

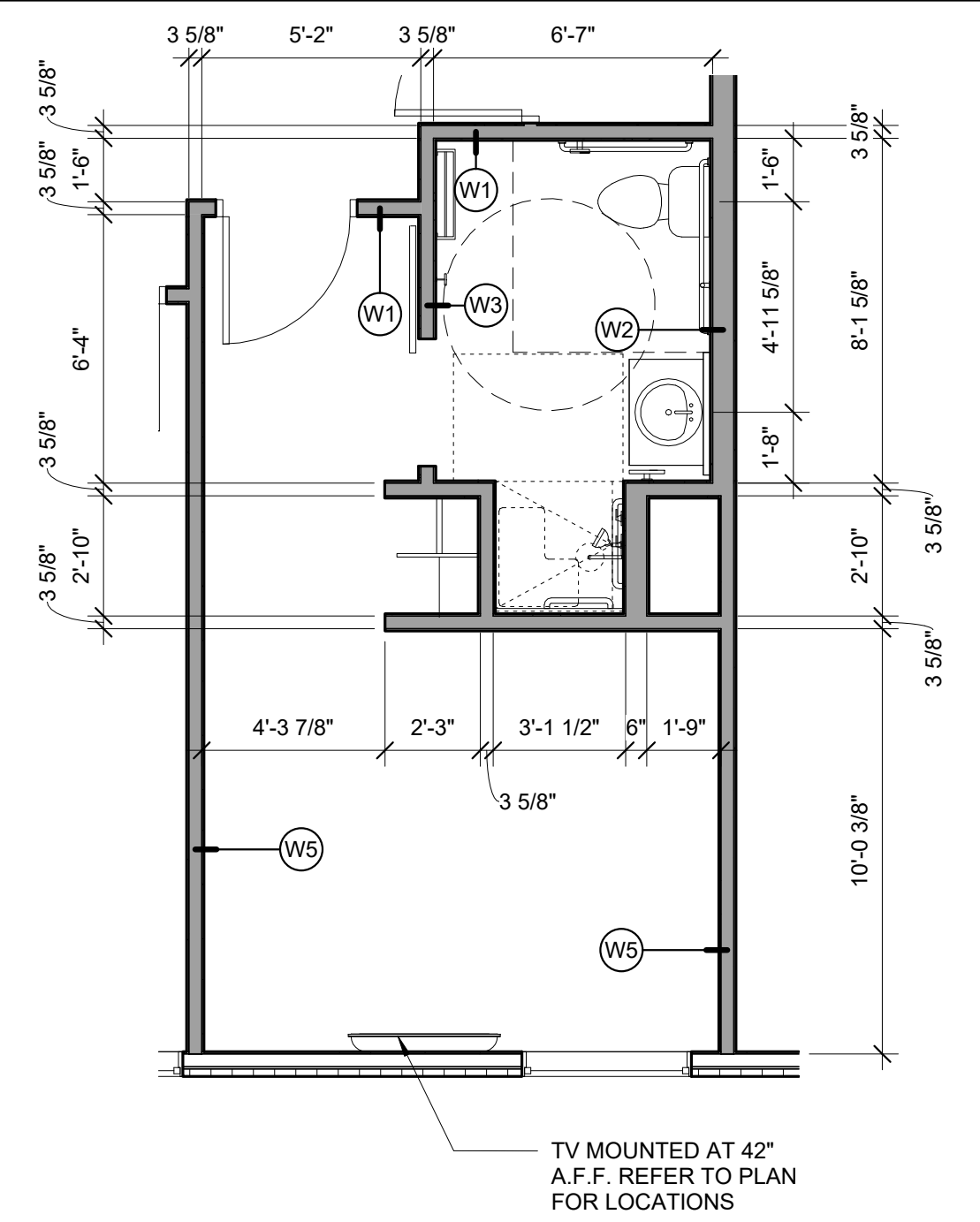

3 TILSON ADA GUEST ROOM ENLARGED PLAN
1/4" = 1'-0"

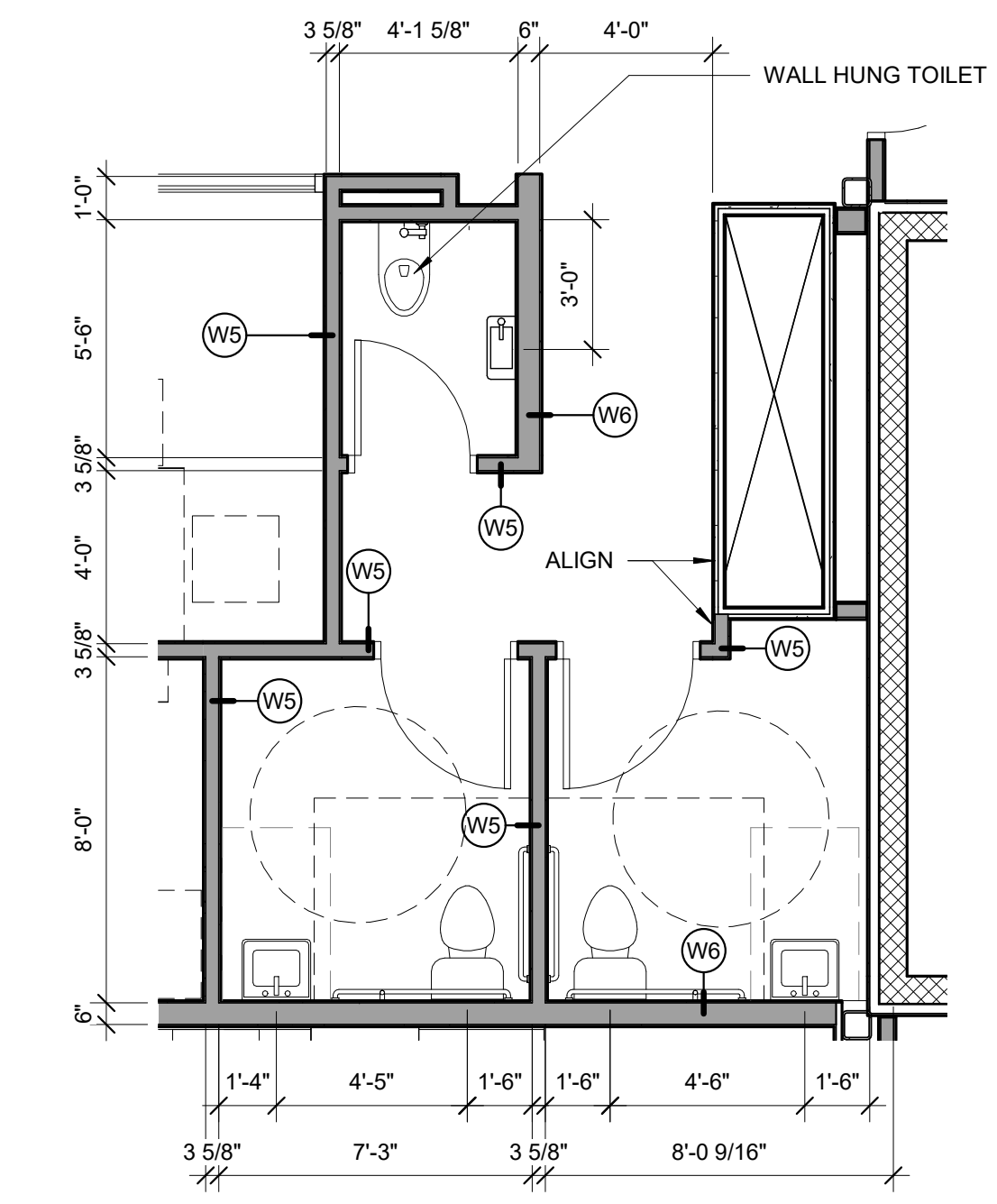

4 TILSON RESTROOM ENLARGED PLAN
1/4" = 1'-0"

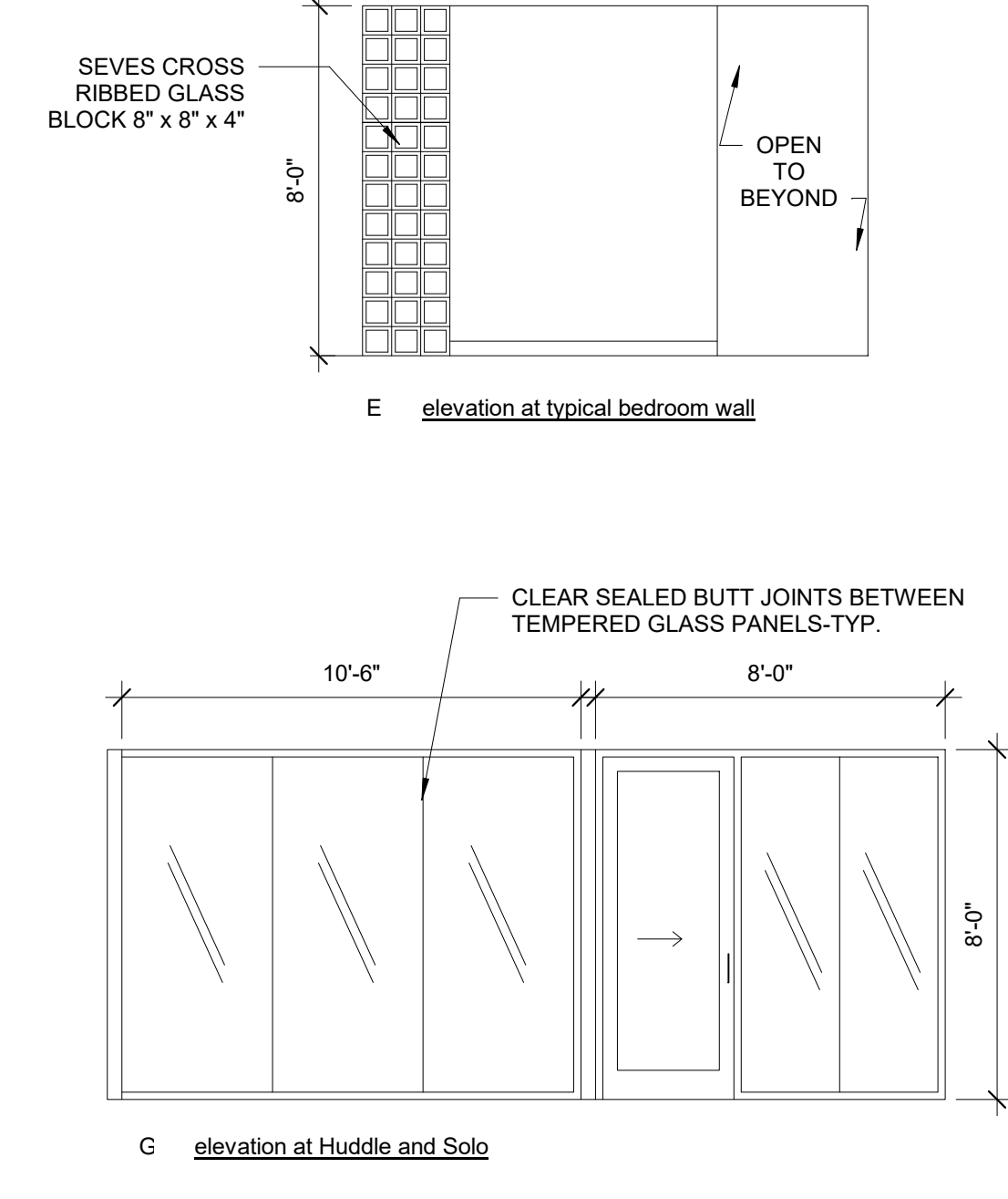
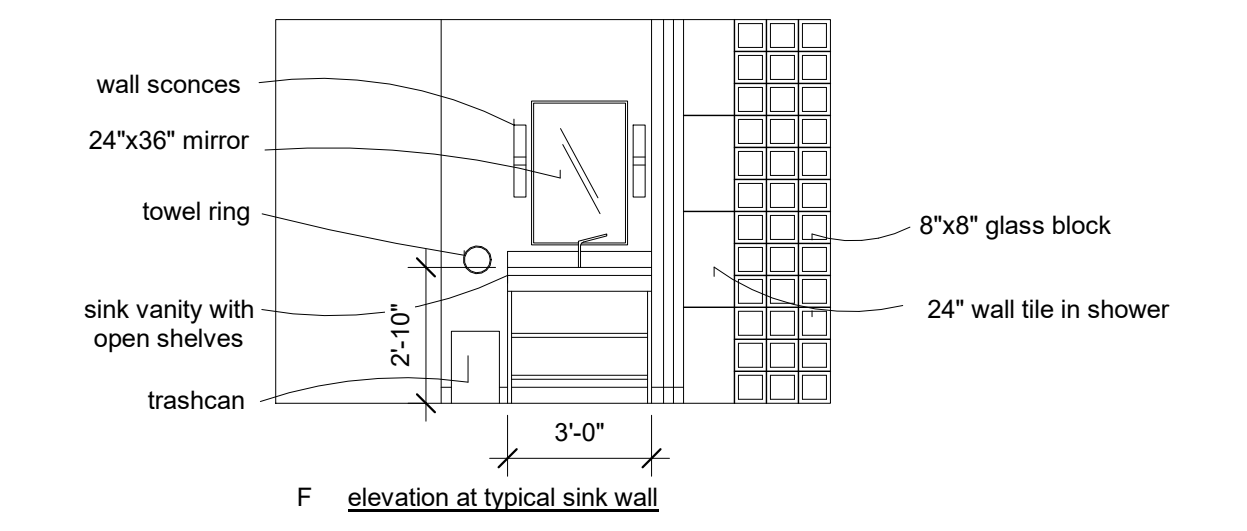
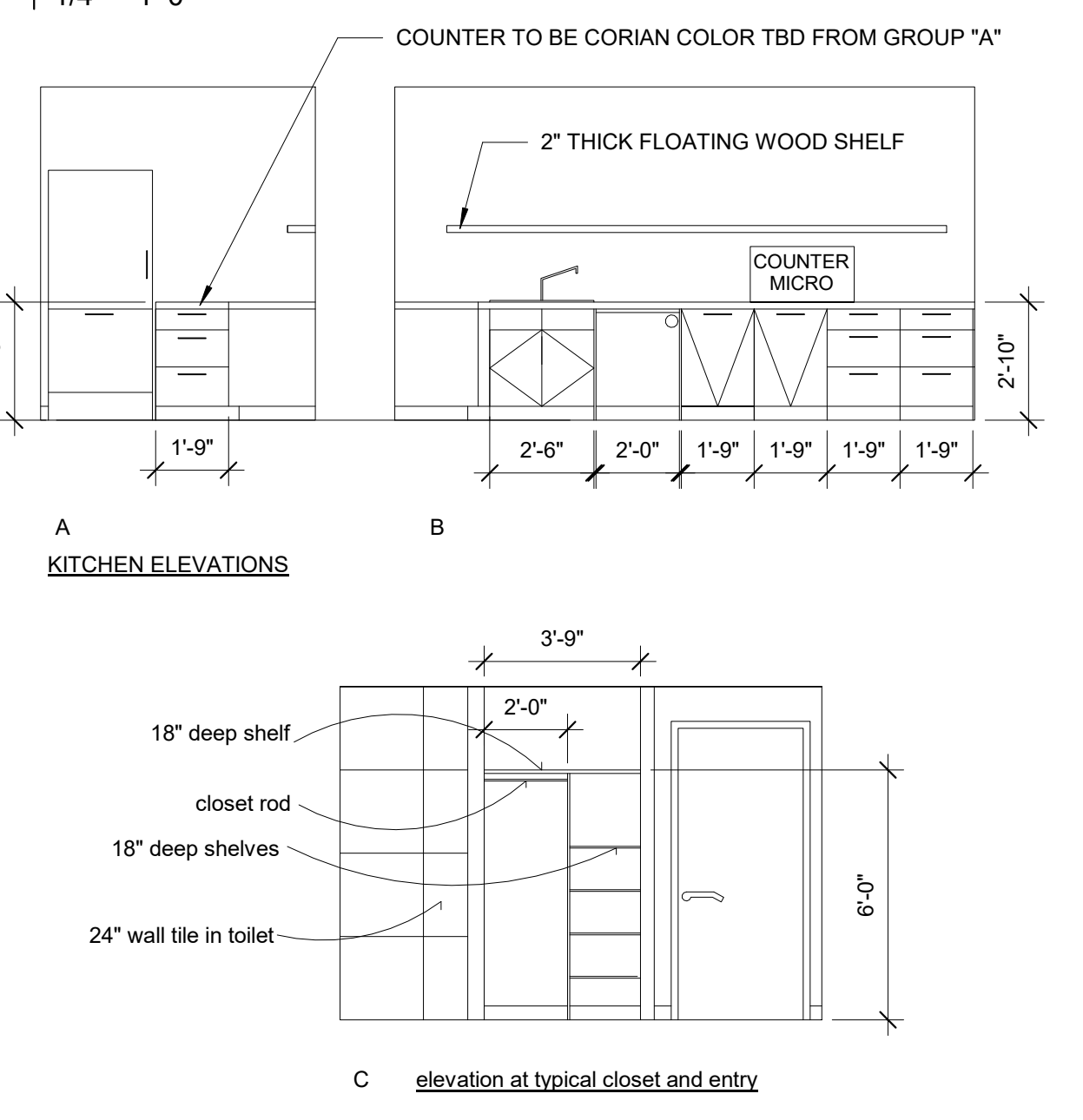

6 3rd floor elevations
1/4" = 1'-0"

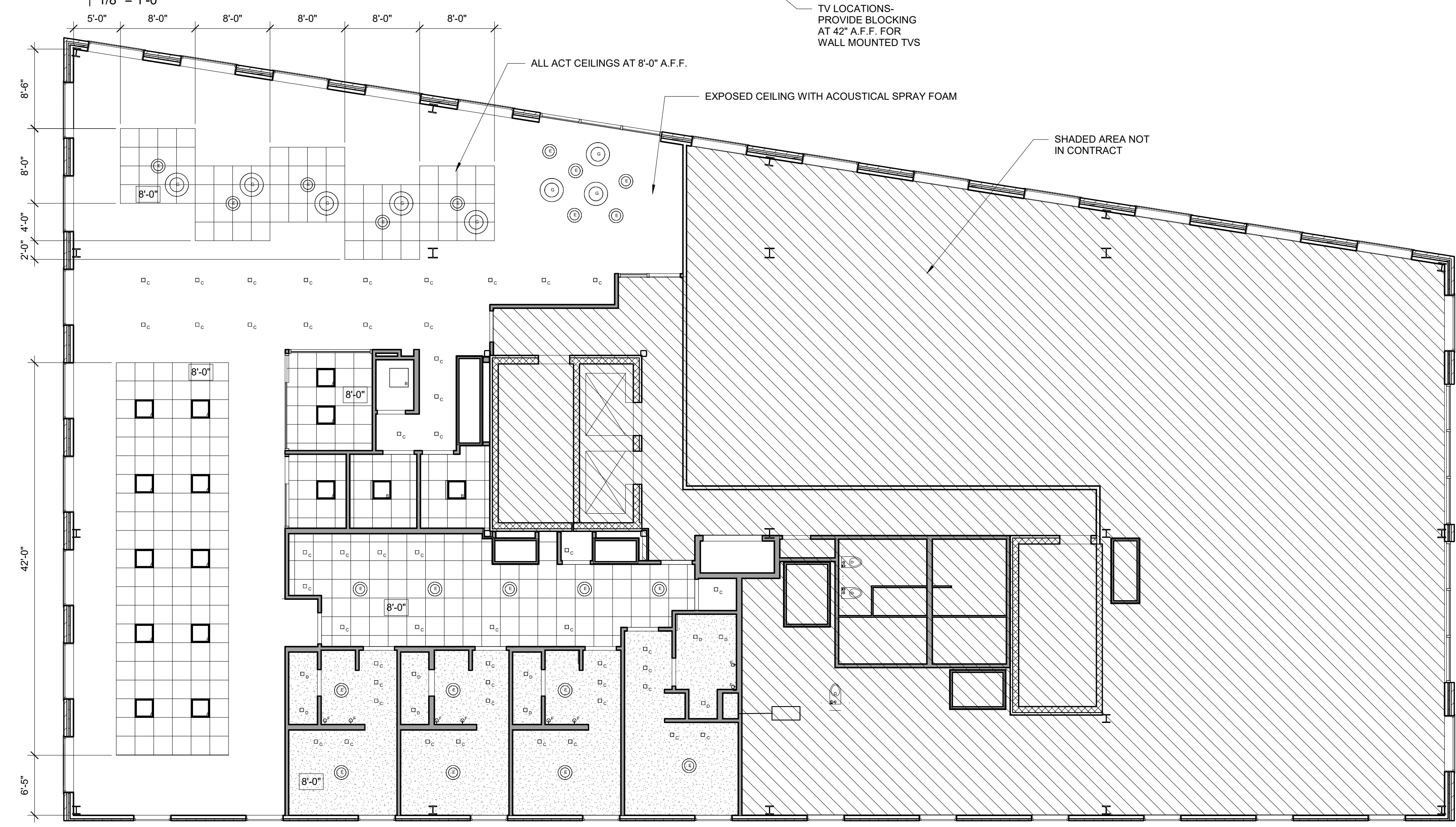

5 3RD FLOOR RCP
1/8" = 1'-0"

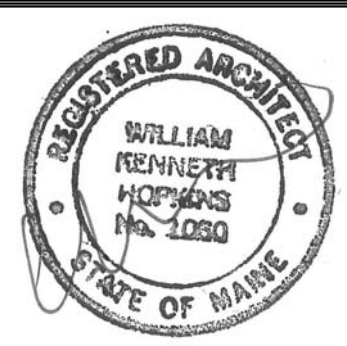

Prepared For:
**16 Middle Street
Associates, LLC**

Consultant:
**ARCHETYPE
architects**
48 Union Wharf Portland, Maine 04101
(207) 772-6022 ARCHETYPE@ARCHETYPEPA.COM

Project:
**16 Middle Street
Condominium**
16 Middle Street
Portland, Maine

Revisions:
Date: **MAR. 1, 2017**
Scale: **As indicated**
**TILSON 3RD FLOOR FIT
UP**

A1.13