

- ROOF FRAMING NOTES:**
- FOR TYPICAL DETAILS AND GENERAL NOTES SEE DWG. S2.01.
  - "C..." INDICATES COLUMN MARK. FOR COLUMN AND BASE PLATE SIZES SEE COLUMN SCHEDULE ON DRAWING S3.01.
  - "EOD" INDICATES EDGE OF DECK DIMENSION FROM COLUMN GRIDLINE OR CL. OF BEAM IF NO GRIDLINE IS INDICATED.
  - "BRACE X" INDICATES A BRACED FRAME. SEE DRAWING S3.02 FOR BRACE ELEVATIONS AND DETAILS.
  - "TOS EL." INDICATES TOP OF STEEL ELEVATION. (TOP OF JOIST 0'-2 1/2" ABOVE TOS ELEVATION UNO).
  - "TOJ EL." INDICATES TOP OF JOIST ELEVATION.
  - "BOS EL." INDICATES BOTTOM OF STEEL ELEVATION.
  - INDICATES SPAN OF METAL DECK.
  - "JH" INDICATES BEAM ELEVATION AT JOIST HEIGHT. (TOP OF STEEL BEAM = TOP OF JOIST ELEVATION).
  - — — INDICATES UPLIFT (HORIZONTAL) BRIDGING AT FIRST PANEL POINT OF BOTTOM CHORD OF JOISTS.
  - — — INDICATES HORIZONTAL BRIDGING OF TOP AND BOTTOM CHORD OF JOISTS.
  - >>> <<< INDICATES (WELDED) CROSS BRIDGING OF JOISTS.
  - xxx INDICATES CONCENTRATED LOAD IN KIPS ON JOIST.
  - PROVIDE FUDDLE WELDS AND SIDELAP FASTENERS PER ROOF DIAPHRAGM KEY PLAN.
  - PROVIDE TIE JOIST DETAIL AT ALL JOISTS THAT FRAME INTO COLUMNS OR ARE DESIGNATED "TJ".
  - ALL MECHANICAL AND ELECTRICAL CONDUITS, PIPING, AND HUNG SOFFITS SHALL BE SUSPENDED FROM STEEL BEAMS, JOIST GIRDERS OR JOISTS. THESE ITEMS SHALL NOT BE HUNG FROM THE METAL DECK. THIS SUPPLEMENTARY FRAMING SHALL BE SUPPLIED BY THE RESPECTIVE TRADES.
  - LOCATIONS AND DIMENSIONS SHOWN FOR RTUS AND OPENINGS ARE FROM FACE TO FACE OF ANGLES OR FACE OF ANGLES TO CENTER OF JOIST. THE SIZE AND LOCATION OF ROOF OPENING FRAMES SHALL BE VERIFIED AND COORDINATED BY THE GENERAL CONTRACTOR AND THE MECHANICAL CONTRACTOR. SHALL VERIFY ALL ROOF OPENINGS BEFORE SUBMITTING SHOP DRAWINGS. REFER TO "ROOF OPENING AND ROOF TOP UNIT SUPPORT" ON DRAWING SXX FOR FRAMING INFORMATION.
  - ... INDICATES DRAG FORCE IN TOP CHORD OF JOIST GIRDER OR WIDE FLANGE BEAM.
  - JOISTS SHALL BE DESIGNED FOR WIND UPLIFT AS INDICATED ON ROOF UPLIFT KEY PLAN.

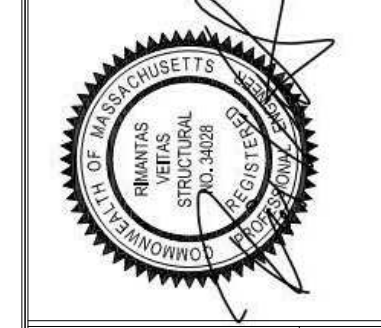

Prepared For:  
**BATEMAN PARTNERS, LLC**  
 P.O. BOX 7486  
 Portland, ME 04112

Consulting Engineer:  
**VEITAS ENGINEERS**  
 68 Granite Street, Suite 101  
 Business: Manchester, 02194  
 Tel: (603) 866-2800 Fax: (603) 866-2805

Architect:  
**ARCHETYPE architects**  
 48 Union Wharf Portland, Maine 04101  
 (207) 772-6022 Fax (207) 772-4056

Project:  
**16 MIDDLE STREET**  
 MIDDLE STREET  
 PORTLAND, MAINE

Revisions:  
 01/15/16 ISSUED FOR FDN. PERMIT  
 06/03/16 ISSUED FOR BUILDING PERMIT

Date: **01/15/16**  
 Scale:  
**ROOF FRAMING PLAN**

**S1.06**

1 ROOF FRAMING PLAN  
 1/8" = 1'-0"

ROOF CONSTRUCTION:  
 1 1/2" PAINTED ROOF DECK. FOR DECK GAUGE AND ATTACHMENT SEE ROOF DIAPHRAGM KEY PLAN ON DWG. S1.06

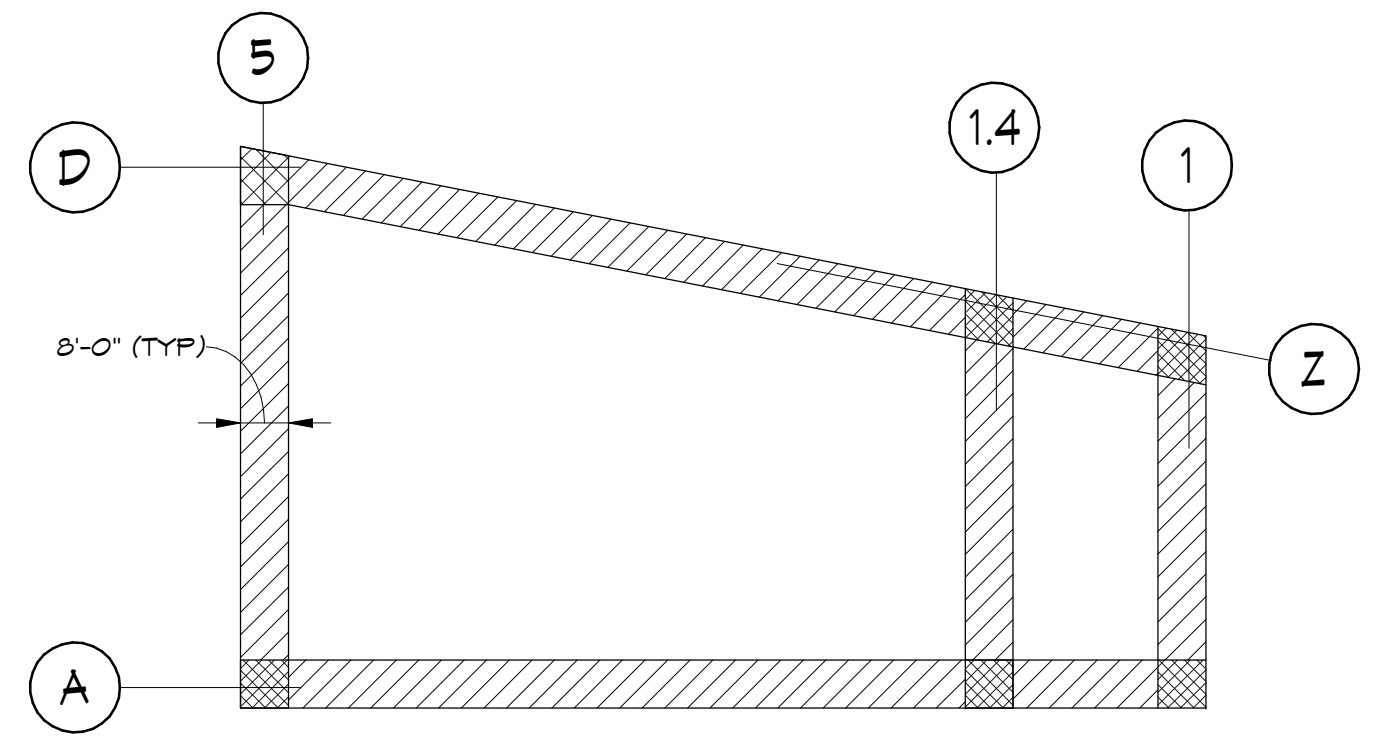

- NOTES:**
- INDICATES 16 PSF NET UPLIFT.
  - INDICATES 31 PSF NET UPLIFT.
  - INDICATES 40 PSF NET UPLIFT.

**ROOF UPLIFT KEY PLAN**

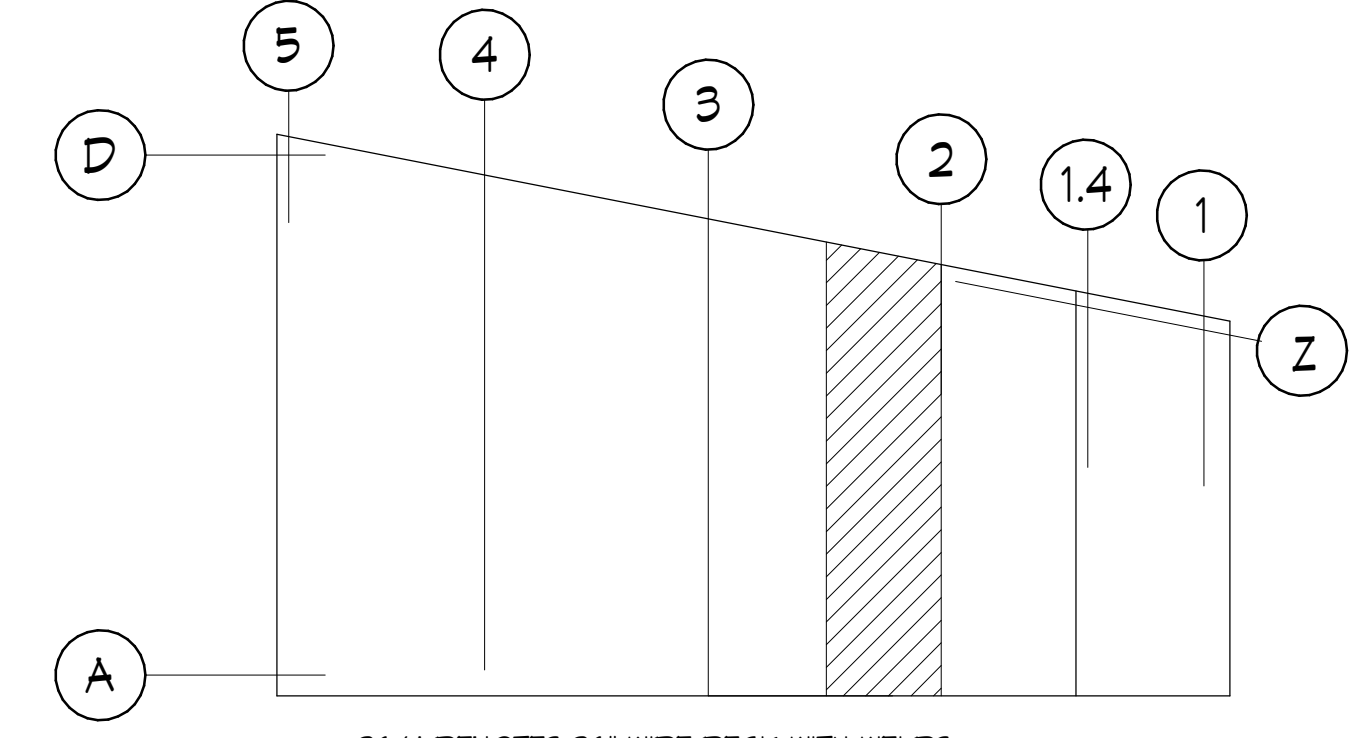

36/4 DENOTES 36" WIDE DECK WITH WELDS AT EVERY OTHER FLUTE SUPPORT.

- NOTES:**
- USE 36/4 PATTERN  
 FRAME FASTENING: 5/8" WELDS  
 SIDE FASTENING: 2 STITCHES #10 SCREWS (BULDEX)  
 1 1/2" - 20 GA. DECK
  - USE 36/4 PATTERN  
 FRAME FASTENING: 5/8" WELDS  
 SIDE FASTENING: 1 STITCH #10 SCREWS (BULDEX)  
 1 1/2" - 20 GA. DECK

**ROOF DIAPHRAGM KEY PLAN**