



## REPORT OF MASONRY BLOCK COMPRESSIVE STRENGTH (ASTM C140)

**CLIENT:** Intercontinental Developers Inc.  
Attn: Mr. Richard Libardoni  
1270 Soldiers Road  
Boston, MA 02135-1003

**PROJECT:** Ocean Gateway Garage  
Portland, ME

**DATE:** January 24, 2008

**REPORT #:** 07-117-044

**Field Representative:** Cast by Genest Concrete  
**Date Cast:** 9/19/07  
**Date Received:** 1/23/08  
**Type:** Hollow Core Block  
**Net Strength:** 3000 psi  
**Standard:** ASTM C140

| Specimen # | Date Tested | Age (days) | Strength (psi) | Average Strength (psi) |
|------------|-------------|------------|----------------|------------------------|
| 1          | 1/24/08     | 121        | 3170           | 2960                   |
| 2          | 1/24/08     | 121        | 3090           |                        |
| *3         | 1/24/08     | 121        | 2610           |                        |

**Remarks:** \* Specimen #3 was a block for control joints.  
All specimens were Ground Faced Masonry Units taken from onsite stock on 1/23/08.



# Standard Test Methods for Sampling and Testing Concrete Masonry Units and Related Units<sup>1</sup>

This standard is issued under the fixed designation C 140; the number immediately following the designation indicates the year of original adoption or, in the case of revision, the year of last revision. A number in parentheses indicates the year of last reapproval. A superscript epsilon ( $\epsilon$ ) indicates an editorial change since the last revision or reapproval.

## 1. Scope\*

1.1 These test methods provide various testing procedures commonly used for evaluating characteristics of concrete masonry units and related concrete units. Methods are provided for sampling, measurement of dimensions, compressive strength, absorption, unit weight (density), moisture content, flexural load, and ballast weight. Not all methods are applicable to all unit types, however.

1.2 Specific testing and reporting procedures are included in annexes to these test methods for the following specific unit types:

- Annex A1—Concrete masonry units (Specifications C 90, C 129)
- Annex A2—Concrete brick (Specifications C 55, C 1634)
- Annex A3—Segmental retaining wall units (Specification C 1372)
- Annex A4—Concrete interlocking paving units (Specification C 936)
- Annex A5—Concrete grid paving units (Specification C 1319)
- Annex A6—Concrete roof pavers (Specification C 1491)

1.3 The test procedures included in these test methods are also applicable to other types of units not referenced in these test methods, but specific testing and reporting requirements for those units are not included.

1.4 These test methods include the following sections:

|   |                         |
|---|-------------------------|
| Scope   | Section 1               |
| Referenced Documents  | 2                       |
| Terminology   | 3                       |
| Significance and Use  | 4                       |
| Sampling  | 5                       |
| Measurement of Dimensions   | 6                       |
| Compressive Strength  | 7                       |
| Absorption  | 8                       |
| Calculations  | 9                       |
| Report  | 10                      |
| Keywords  | 11                      |
| Annexes—Test Procedures   |                         |
| Concrete Masonry Units  | Annex A1                |
| Concrete Brick  | Annex A2                |
| Segmental Retaining Wall Units  | Annex A3                |
| Concrete Interlocking Paving Units  | Annex A4                |
| Concrete Grid Paving Units  | Annex A5                |
| Concrete Roof Pavers  | Annex A6                |
| Determining Plate Thickness Requirements for Compression Testing Worksheet and Test Report for Concrete Masonry Units | Annex A7<br>Appendix X1 |

NOTE 1—The testing laboratory performing these test methods should be evaluated in accordance with Practice C 1093.

1.5 The values stated in inch-pound units are to be regarded as the standard. The values given in parentheses are for information only.

1.6 *This standard does not purport to address all of the safety concerns, if any, associated with its use. It is the responsibility of the user of this standard to establish appropriate safety and health practices and determine the applicability of regulatory limitations prior to use.*

## 2. Referenced Documents

- 2.1 *ASTM Standards:*<sup>2</sup>
- C 55 Specification for Concrete Building Brick
  - C 90 Specification for Loadbearing Concrete Masonry Units
  - C 129 Specification for Nonloadbearing Concrete Masonry Units
  - C 143/C 143M Test Method for Slump of Hydraulic-Cement Concrete
  - C 936 Specification for Solid Concrete Interlocking Paving Units
  - C 1093 Practice for Accreditation of Testing Agencies for Masonry
  - C 1209 Terminology of Concrete Masonry Units and Related Units
  - C 1232 Terminology of Masonry
  - C 1319 Specification for Concrete Grid Paving Units
  - C 1372 Specification for Dry-Cast Segmental Retaining Wall Units
  - C 1491 Specification for Concrete Roof Pavers
  - C 1552 Practice for Capping Concrete Masonry Units, Related Units and Masonry Prisms for Compression Testing
  - C 1634 Specification for Concrete Facing Brick
  - E 4 Practices for Force Verification of Testing Machines
  - E 6 Terminology Relating to Methods of Mechanical Testing

<sup>1</sup> These test methods are under the jurisdiction of ASTM Committee C15 on Manufactured Masonry Units and are the direct responsibility of Subcommittee C15.03 on Concrete Masonry Units and Related Units.

Current edition approved Dec. 15, 2007. Published January 2008. Originally approved in 1938. Last previous edition approved in 2007 as C 140 – 07.

<sup>2</sup> For referenced ASTM standards, visit the ASTM website, [www.astm.org](http://www.astm.org), or contact ASTM Customer Service at [service@astm.org](mailto:service@astm.org). For *Annual Book of ASTM Standards* volume information, refer to the standard's Document Summary page on the ASTM website.

\*A Summary of Changes section appears at the end of this standard.

### 3. Terminology

3.1 Terminology defined in Terminologies C 1209, C 1232, and E 6 shall apply for these test methods.

### 4. Significance and Use

4.1 These test methods provide general testing requirements for application to a broad range of concrete products. Those general testing requirements are included in the body of this standard.

NOTE 2—Consult manufacturer, supplier, product specifications, or other resources for more specific measurement or testing guidelines for those products not addressed with the annex of this standard.

4.2 These test methods provide specific testing requirements in two distinct sections, the requirements applicable to all units covered by these test methods and those applicable to the specific unit types. The requirements applicable to all units are included in the body of these test methods and those applicable to the specific unit types are included within the annexes.

### 5. Sampling

#### 5.1 Selection of Test Specimens:

5.1.1 For purposes of testing, full-sized units shall be selected by the purchaser or authorized representative. The selected specimens shall be of similar configuration and dimensions. Specimens shall be representative of the whole lot of units from which they are selected.

5.1.2 The term “lot” refers to any number of concrete masonry units of any configuration or dimension manufactured by the producer using the same materials, concrete mix design, manufacturing process, and curing method.

5.2 *Number of Specimens*—Unless specified otherwise in the applicable annex, for the compressive strength, absorption, unit weight (density), and moisture content determinations, six units shall be selected from each lot of 10 000 units or fraction thereof and 12 units from each lot of more than 10 000 and less than 100 000 units. For lots of more than 100 000 units, six units shall be selected from each 50 000 units or fraction thereof contained in the lot. Additional specimens shall be taken if directed by the purchaser.

5.3 *Identification*—Mark each specimen so that it may be identified at any time. Markings shall cover not more than 5 % of the surface area of the specimen.

5.4 *Received Weight*—Weigh each specimen immediately after sampling and marking, and record as  $W_r$  (received weight). Record time and place  $W_r$  was measured.

NOTE 3—Received weights often have direct relationships with other unit properties and are therefore a useful method of evaluating results or for sorting purposes. The weight of a concrete masonry unit and related unit changes with time and exposure conditions, primarily as a result of the moisture within the unit. Therefore, to understand the context of a received weight value, it is also important to understand the point in time and the frame of reference when that weight was determined. “Time and place” should not refer to when and where the unit was sampled but when and where the received weights were determined. In addition to date and time references, it is also important to know if those weights were determined after units reached equilibrium with lab environment, or before units were shipped, or after delivery to the job site, and so forth.

### 6. Measurement of Dimensions

#### 6.1 Apparatus:

6.1.1 *Steel Scale*—shall have divisions not greater than  $\frac{1}{16}$  in. (2.5 mm).

6.1.2 *Calipers*—shall have divisions not greater than  $\frac{1}{100}$  in. (0.25 mm).

6.2 *Specimens*—Three full-size units shall be selected for measurement of dimensions.

6.3 *Measurements*—Measure specimens in accordance with the applicable annex of this standard. For those products not covered by the annexes of this standard, measure overall dimensions (width, height, length) in at least two locations on opposite sides of the specimen. Document location of each measurement on a sketch or photograph of the specimen.

NOTE 4—Specimens used for measurement of dimensions may be used in other tests.

### 7. Compressive Strength

#### 7.1 Test Apparatus:

7.1.1 The testing machine shall have an accuracy of  $\pm 1.0$  % over the anticipated load range. The upper platen shall be a spherically seated, hardened metal block firmly attached at the center of the upper head of the machine. The center of the sphere shall lie at the center of the surface held in its spherical seat but shall be free to turn in any direction, and its perimeter shall have at least  $\frac{1}{4}$  in. (6.3 mm) clearance from the head to accommodate specimens whose bearing surfaces are not parallel. The diameter of the upper platen (determined in accordance with Annex A7) shall be at least 6 in. (150 mm). A hardened metal bearing plate may be used beneath the specimen to minimize wear of the lower platen of the machine.

7.1.2 When the bearing area of the upper platen or lower platen is not sufficient to cover the area of the specimen, a single steel plate with a thickness equal to at least the distance from the edge of the platen to the most distant corner of the specimen shall be placed between the platen and the capped specimen. The length and width of the steel plate shall be at least  $\frac{1}{4}$  in. (6 mm) greater than the length and width of the units.

7.1.3 The surfaces of the platen or plate intended for contact with the specimen shall have a hardness not less than HRC 60 (BHN 620). The surfaces of the platen and plate shall not depart from plane surfaces by more than 0.001 in. (0.03 mm) in any 6 in. (150 mm) dimension.

NOTE 5—Research has shown that thickness of bearing plates has a significant effect on the tested compressive strength of masonry units when the bearing area of the platen is not sufficient to cover the area of the specimen. Plate bending results in nonuniform stress distributions that can influence the failure mechanisms of the tested specimens. The magnitude of this effect is controlled by the stiffness of the plate, the size of the specimen tested, and the strength of the specimen. Tested compressive strengths will typically increase with increased plate thickness and with reduced distance to the furthest corner of the specimen. Some testing laboratories have limitations that limit the practicality of eliminating plate bending entirely. Therefore the plate thickness requirements in 7.1 are intended to provide an adequate level of accuracy in the compression test results so as to conform to the limits of practicality of the testing laboratory.

NOTE 6—Annex A7 includes guidance on determining the required plate thickness based on the configuration of the test specimen and the test machine.

7.1.4 The testing machine shall be verified in accordance with Practices E 4 at a frequency defined by Practice C 1093.

**7.2 Test Specimens:**

7.2.1 Unless specified otherwise in the applicable annex, test three specimens in compression.

7.2.2 When possible and unless specified otherwise in the applicable annex, specimens shall be full-sized units. When the units cannot be tested full-size due to specimen configuration or testing machine requirements, reduce the specimen size in accordance with Annex A1.

7.2.3 After delivery to the laboratory, store compression specimens (unstacked and separated by not less than 0.5 in. (13 mm) on all sides) continuously in air at a temperature of  $75 \pm 15^\circ\text{F}$  ( $24 \pm 8^\circ\text{C}$ ) and a relative humidity of less than 80 % for not less than 48 h. Alternatively, if compression results are required sooner, store units unstacked in the same environment described above with a current of air from an electric fan passing over them for a period of not less than 4 h. Continue passing air over the specimens until two successive weighings at intervals of 2 h show an increment of loss not greater than 0.2 % of the previously determined weight of the specimen and until no moisture or dampness is visible on any surface of the unit. Specimens shall not be subjected to oven-drying.

NOTE 7—In this test method, net area (other than certain solid units, see 9.4) is determined from specimens other than those subjected to compression testing. The compressive strength method is based on the assumption that units used for determining net volume (absorption specimens) have the same net volume as units used for compression testing. Sampled split face units, which have irregular surfaces, should be divided at the time they are sampled from the lot, such that the absorption test specimens have a net volume that is visually representative and a weight that is representative of the compression test specimens.

7.2.4 Where saw-cutting of test specimens is allowed or required by the standard or applicable annex, sawing shall be performed in an accurate, competent manner, subjecting the specimen to as little saw vibration as possible. Use a diamond saw blade of proper hardness. If the specimen is wetted during sawing, allow the specimen to dry to equilibrium with laboratory air conditions before testing, using the procedures outlined in 7.2.3.

7.2.5 If compression test specimens have been saw-cut from full-sized units and the net area of the compression test specimens can not be determined by 9.4.1, saw-cut an additional three units to the dimensions and configuration of the three compression test specimens. The average net area for the saw-cut compression specimens shall be taken as the average net area of the additional three saw-cut units calculated as required in 9.4. Calculated net volumes of saw-cut specimens shall not be used in calculating equivalent thickness.

7.3 *Capping*—Cap test specimens in accordance with Practice C 1552.

**7.4 Compression Testing Procedure:**

7.4.1 *Position of Specimens*—Test specimens with the centroid of their bearing surfaces aligned vertically with the center of thrust of the spherically seated steel bearing block of the testing machine (Note 8). Except for special units intended for

use with their cores in a horizontal direction, test all hollow concrete masonry units with their cores in a vertical direction. Test masonry units that are 100 % solid and special hollow units intended for use with their hollow cores in a horizontal direction in the same direction as in service.

NOTE 8—For those masonry units that are symmetrical about an axis, the location of that axis can be determined geometrically by dividing the dimension perpendicular to that axis (but in the same plane) by two. For those masonry units that are nonsymmetrical about an axis, the location of that axis can be determined by balancing the masonry unit on a knife edge or a metal rod placed parallel to that axis. If a metal rod is used, the rod shall be straight, cylindrical (able to roll freely on a flat surface), have a diameter of not less than  $\frac{1}{4}$  in. (6.4 mm) and not more than  $\frac{3}{4}$  in. (19.1 mm), and its length shall be sufficient to extend past each end of the specimen when placed upon it. The metal rod shall be placed on a smooth, flat, level surface. Once determined, the centroidal axis shall be marked on the end of the unit using a pencil or marker having a marking width of not greater than 0.05 in. (1.3 mm). A tamping rod used for consolidation of concrete and grout for slump tests performed in accordance with Test Method C 143/C 143M is often used as a balancing rod.

7.4.2 *Moisture Condition of Specimens*—At the time the specimens are tested, they shall be free of visible moisture or dampness.

7.4.3 *Speed of Testing*—Apply the load (up to one half of the expected maximum load) at any convenient rate, after which adjust the controls of the machine as required to give a uniform rate of travel of the moving head such that the remaining load is applied in not less than 1 nor more than 2 min.

7.4.4 *Maximum Load*—Record the maximum compressive load in pounds (newtons) as  $P_{max}$ .

## 8. Absorption

8.1 *Apparatus*—The balance used shall be sensitive to within 0.5 % of the weight of the smallest specimen tested.

**8.2 Test Specimens:**

8.2.1 Unless specified otherwise in the applicable annex, test three specimens in absorption.

8.2.2 Unless specified otherwise in the applicable annex, tests shall be performed on full-sized units or specimens saw-cut from full-sized units. Calculated values for absorption and density of reduced-size absorption specimens shall be considered as representative of the whole unit.

**8.3 Procedure:**

8.3.1 *Saturation*—Immerse the test specimens in water at a temperature of 60 to 80°F (15.6 to 26.7°C) for 24 h. Weigh the specimens while suspended by a metal wire and completely submerged in water and record  $W_i$  (immersed weight). Remove from the water and allow to drain for 1 min  $\pm$  5 s by placing them on a  $\frac{3}{8}$ -in. (9.5-mm) or coarser wire mesh, removing visible surface water with a damp cloth; weigh and record as  $W_s$  (saturated weight).

8.3.2 *Drying*—Subsequent to saturation, dry all specimens in a ventilated oven at 212 to 239°F (100 to 115°C) for not less than 24 h and until two successive weighings at intervals of 2 h show an increment of loss not greater than 0.2 % of the last previously determined weight of the specimen. Record weight of dried specimens as  $W_d$  (oven-dry weight).

## 9. Calculations

9.1 *Absorption*—Calculate absorption as follows:

$$\text{Absorption, lb/ft}^3 = [(W_s - W_d)/(W_s - W_i)] \times 62.4 \quad (1)$$

$$\text{Absorption, kg/m}^3 = [(W_s - W_d)/(W_s - W_i)] \times 1000$$

$$\text{Absorption, \%} = [(W_s - W_d)/W_d] \times 100$$

where:

$W_s$  = saturated weight of specimen, lb (kg),

$W_i$  = immersed weight of specimen, lb (kg), and

$W_d$  = oven-dry weight of specimen, lb (kg).

9.2 *Moisture Content*—Calculate the moisture content of the unit at the time it is sampled (when  $W_r$  is measured) as follows:

$$\text{Moisture Content, \% of total absorption} = [(W_r - W_d)/(W_s - W_d)] \times 100 \quad (2)$$

where:

$W_r$  = received weight of unit, lb (kg),

$W_d$  = oven-dry weight of unit, lb (kg), and

$W_s$  = saturated weight of unit, lb (kg).

NOTE 9—When determining the moisture content of a unit or set of units, the value determined is a measure of the water content of a unit based upon the received weight of the unit  $W_r$ . Thus, the moisture content calculation above is only applicable to the unit moisture content at the time the received weight,  $W_r$ , is obtained.

9.3 *Density*—Calculate oven-dry density as follows:

$$\text{Density (D), lb/ft}^3 = [W_d/(W_s - W_i)] \times 62.4 \quad (3)$$

$$\text{Density (D), kg/m}^3 = [W_d/(W_s - W_i)] \times 1000$$

where:

$W_d$  = oven-dry weight of specimen, lb (kg),

$W_s$  = saturated weight of specimen, lb (kg), and

$W_i$  = immersed weight of specimen, lb (kg).

9.4 *Average Net Area*—Calculate average net area as follows:

$$\text{Net Volume (V}_n\text{), ft}^3 = W_d D = (W_s - W_i)/62.4 \quad (4)$$

$$\text{Net Volume (V}_n\text{), mm}^3 = W_d D = (W_s - W_i) \times 10^6$$

$$\text{Average Net Area (A}_n\text{), in.}^2 = (V_n \times 1728)/H$$

$$\text{Average Net Area (A}_n\text{), mm}^2 = V_n/H$$

where:

$V_n$  = net volume of specimen, ft<sup>3</sup> (mm<sup>3</sup>),

$W_d$  = oven-dry weight of specimen, lb (kg),

$D$  = oven-dry density of specimen, lb/ft<sup>3</sup> (kg/m<sup>3</sup>),

$W_s$  = saturated weight of specimen, lb (kg),

$W_i$  = immersed weight of specimen, lb (kg),

$A_n$  = average net area of specimen, in.<sup>2</sup> (mm<sup>2</sup>), and

$H$  = average height of specimen, in. (mm).

9.4.1 Except for irregularly shaped specimens, such as those with split surfaces, calculate the net area of coupons and those specimens whose net cross-sectional area in every plane parallel to the bearing surface is the gross cross-sectional area measured in the same plane, as follows:

$$\text{Net Area (A}_n\text{), in.}^2 \text{ (mm}^2\text{)} = L \times W \quad (5)$$

where:

$A_n$  = net area of the coupon or specimen, in.<sup>2</sup> (mm<sup>2</sup>),

$L$  = average length of the coupon or specimen, in. (mm), and

$W$  = average width of the coupon or specimen, in. (mm).

9.5 *Gross Area*—Calculate gross area as follows:

$$\text{Gross Area (A}_g\text{), in.}^2 \text{ (mm}^2\text{)} = L \times W \quad (6)$$

where:

$A_g$  = gross area of the specimen, in.<sup>2</sup> (mm<sup>2</sup>),

$L$  = average length of the specimen, in. (mm), and

$W$  = average width of the specimen, in. (mm).

9.5.1 The gross cross-sectional area of a specimen is the total area of a section perpendicular to the direction of the load, including areas within cells and reentrant spaces, unless these spaces are to be occupied in the masonry by portions of adjacent masonry.

9.6 *Compressive Strength*:

9.6.1 *Net Area Compressive Strength*—Calculate the net area compressive strength of the specimen as follows:

$$\text{Net Area Compressive Strength, psi (MPa)} = P_{max}/A_n \quad (7)$$

where:

$P_{max}$  = maximum compressive load, lb (N), and

$A_n$  = average net area of specimen, in.<sup>2</sup> (mm<sup>2</sup>).

9.6.2 *Gross Area Compressive Strength*—Calculate the gross area compressive strength of the specimen as follows:

$$\text{Gross Area Compressive Strength, psi (MPa)} = P_{max}/A_g \quad (8)$$

where:

$P_{max}$  = maximum compressive load, lb (N), and

$A_g$  = gross area of specimen, in.<sup>2</sup> (mm<sup>2</sup>).

## 10. Report

10.1 A complete report shall include the following general information:

10.1.1 Name and address of the testing laboratory,

10.1.2 Identification of the report and the date of issue,

10.1.3 Name and address of the client or the identification of the project,

10.1.4 Description and identification of the test sample,

10.1.5 Date of receipt of the test sample,

10.1.6 Date(s) of test performance,

10.1.7 Identification of the standard test method used and a notation of any known deviation from the test method,

10.1.8 Name of the person(s) accepting technical responsibility for the test report,

10.1.9 Age of test specimens, if known,

10.1.10 Identification of subcontractor test results, and

10.1.11 A photograph, sketch, or description of the configuration of the unit.

10.2 A complete report shall also include the results of all tests and other reporting requirements from the applicable annex.

## 11. Keywords

11.1 absorption; compressive strength; concrete masonry units; density; equivalent thickness; equivalent web thickness; face shell; moisture content; roof paver; webs; web thickness

## ANNEXES

### (Mandatory Information)

#### A1. TEST PROCEDURES FOR CONCRETE MASONRY UNITS

##### A1.1 Scope

A1.1.1 This annex includes testing requirements that are particular for concrete masonry units that are manufactured for compliance with the following unit specifications: C 90, C 129.

##### A1.2 Measurement

A1.2.1 For each unit, measure with a steel scale or caliper and record the width ( $W$ ) across the top and bottom bearing surfaces at mid-length, height ( $H$ ) at mid-length of each face, and length ( $L$ ) at mid-height of each face to the nearest division of the scale.

A1.2.2 For each unit, measure with a caliper the face shell thicknesses ( $t_{fs}$ ) and web thicknesses ( $t_w$ ) at the thinnest point of each such element  $\frac{1}{2}$  in. (12.7 mm) down from the top surface of the unit as manufactured (typically the bottom surface of the unit as laid) and record to the nearest division of the caliper. Where the thinnest point of opposite face shells differ in thickness by less than  $\frac{1}{8}$  in. (3.2 mm), average their measurements to determine the minimum face shell thickness for that unit. Average the measurements of all of the webs in each unit to determine the minimum web thickness for that unit. Exclude webs having a thickness less than 0.75 in. (19.1 mm) when determining minimum web thickness. Disregard grooves, scores, and similar details in the measurements.

##### A1.3 Compressive Strength Testing

A1.3.1 *Test Specimens*—Specimens shall be full-sized units except as modified in A1.3.1.1 through A1.3.1.3.

A1.3.1.1 Unsupported projections having a length greater than the thickness of the projection shall be removed by saw-cutting. For units with recessed webs, the face shell projecting above the web shall be removed by saw-cutting to provide a full bearing surface over the net cross section of the unit. Where the resulting unit height would be reduced by more than one-third of the original unit height, the unit shall be coupon tested in accordance with A1.3.1.3.

A1.3.1.2 When compression testing full-sized units that are too large for the test machine's bearing block and platens or are beyond the load capacity of the test machine, saw-cut the units to properly size them to conform to the capabilities of the testing machine. The resulting specimen shall have no face shell projections or irregular webs and shall be fully enclosed in a four-sided cell or cells. The compressive strength of the segment shall be considered to be the compressive strength of the whole unit.

A1.3.1.3 When compression testing units of unusual size and shape (see Note A1.1), the specimens shall be saw-cut to remove any face shell projections. The resulting specimen shall be a cell or cells containing four sides that will ensure a 100 % bearing surface. Where saw-cutting will not result in an enclosed four-sided unit, the specimen shall be a coupon cut

from a face shell of each unit. The coupon size shall have a height to thickness ratio of 2 to 1 before capping and a length to thickness ratio of 4 to 1. The thickness of the coupon shall be as large as possible based on the configuration of the unit and the capacities of the testing machine and shall not be less than 1.25 in. (30 mm). The coupon shall be cut from the unit such that the coupon height dimension is in the same direction as the unit's height dimension. The compressive strength of the coupon shall be the net area compressive strength of the whole unit.

NOTE A1.1—Examples of units having unusual size or shape include, but are not limited to, bond beam units, open end units, and pilaster units.

A1.3.2 *Testing*—Cap and test specimens in accordance with 7.3 and 7.4.

##### A1.4 Absorption Testing

A1.4.1 *Test Specimens*—Specimens shall be in accordance with 8.2 except as modified in A1.4.1.1.

A1.4.1.1 Tests shall be performed on full-size units when test results are to be used to determine moisture content in accordance with 9.2 or equivalent thickness in accordance with A1.5.3.

A1.4.2 *Testing*—Perform absorption tests in accordance with 8.3.

##### A1.5 Calculations

A1.5.1 Calculate absorption, moisture content, density, average net area, and net area compressive strength in accordance with Section 9.

A1.5.2 *Equivalent Web Thickness*—Equivalent web thickness of each unit (in inches per linear foot of specimen) is equal to the sum of the measured thicknesses of all webs whose individual thickness is equal to or greater than 0.75 in. (19.1 mm) in the unit multiplied by 12 and divided by the length of the unit.

NOTE A1.2—Equivalent web thickness does not apply to the portion of the unit to be filled with grout. The length of that portion should be deducted from the overall length of the unit.

A1.5.3 *Equivalent Thickness*—Equivalent thickness for concrete masonry is defined as the average thickness of solid material in the unit and is calculated as follows:

$$T_e, \text{ in.} = [V_n / (L \times H)] \times 1728 \quad (\text{A1.1})$$

$$T_e, \text{ mm} = [V_n / (L \times H)]$$

where:

- $T_e$  = equivalent thickness, in. (mm),
- $V_n$  = average net volume of full-size units, ft<sup>3</sup> (mm<sup>3</sup>) (see 9.4),
- $L$  = average length of full-size units, in. (mm) (see A1.2.1), and

$H$  = average height of full-size units, in. (mm) (see A1.2.1).

A1.5.3.1 Equivalent thickness shall only be calculated and reported for full-size concrete masonry units.

### A1.6 Report

A1.6.1 Test reports shall include all of the information in Section 10 and the following:

A1.6.2 The net area compressive strength to the nearest 10 psi (0.1 MPa) separately for each specimen and as the average for three specimens as determined by 9.6.1.

A1.6.3 The absorption results to the nearest 0.1 pcf (1 kg/m<sup>3</sup>) and density results to the nearest 0.1 pcf (1 kg/m<sup>3</sup>) separately for each unit and as the average for the three units as determined by 9.1 and 9.3. If absorption tests are performed on specimens other than full-size units, report the reason for testing reduced-size units and the size and configuration of the specimens tested.

A1.6.4 The average width, height, and length to the nearest 0.1 in. (2.5 mm) of each specimen as determined by A1.2.1.

A1.6.5 The minimum face shell thickness to the nearest 0.01 in. (0.25 mm) as an average of the minimum face shell thicknesses recorded for each of three specimens as determined by A1.2.2.

A1.6.6 The minimum web thickness to the nearest 0.1 in. (2.5 mm) as an average of the minimum web thicknesses recorded for each of three specimens as determined by A1.2.2.

A1.6.7 The equivalent web thickness to the nearest 0.1 in. (2.5 mm) as an average for three specimens as determined by A1.5.2.

A1.6.8 The equivalent thickness to the nearest 0.1 in. (2.5 mm) as an average for three specimens as determined by A1.5.3, when required.

A1.6.9 The moisture content as an average for three specimens as determined by 9.2, when required.

A1.6.10 The time at which moisture content is determined (when  $W_r$  is measured).

## A2. TEST PROCEDURES FOR CONCRETE BRICK

### A2.1 Scope

A2.1.1 This annex includes testing requirements that are particular for concrete brick that are manufactured for compliance with the following unit specifications: C 55, C 1634.

### A2.2 Measurement of Dimension

A2.2.1 For each unit, measure with a steel scale or caliper and record the width ( $W$ ) across the top and bottom bearing surfaces at mid-length, height ( $H$ ) at mid-length of each face, and length ( $L$ ) at mid-height of each face.

A2.2.2 For brick containing cores, measure with a caliper  $\frac{1}{2}$  in. down from the top surface of the unit and record the minimum distance from the any edge of each brick to the nearest edge of the nearest core.

### A2.3 Compressive Strength Testing

A2.3.1 *Test Specimens*—Specimens shall be full-sized units except as modified in A2.3.1.1.

A2.3.1.1 When compression testing full-sized units that are too large for the test machine's bearing block and platens or are beyond the load capacity of the test machine, saw-cut the units to properly size them to conform to the capabilities of the testing machine. The resulting specimen shall have no projections or irregular features and cores shall be fully enclosed. The compressive strength of the segment shall be considered to be the compressive strength of the whole unit.

A2.3.1.2 Tested specimens shall have an aspect ratio (height divided by its least lateral dimension,  $h/t$ ) of  $0.6 \pm 0.1$ . If full-size units are not within that dimensional ratio requirement, the units shall be saw-cut to produce a compression test specimen with that dimensional ratio prior to capping. The height of the compression specimen shall be greater than or equal to 2 in. (50.8 mm).

A2.3.2 *Testing*—Cap and test specimens in accordance with 7.3 and 7.4.

### A2.4 Absorption Testing

A2.4.1 *Test Specimens*—Specimens shall be in accordance with 8.2 except as modified in A2.4.1.1.

A2.4.1.1 Tests shall be performed on full-size units when test results are to be used to determine equivalent thickness.

A2.4.2 *Testing*—Perform absorption tests in accordance with 8.3.

### A2.5 Calculations

A2.5.1 Calculate absorption, moisture content, density, gross area, and gross area compressive strength per Section 9.

A2.5.2 *Equivalent Thickness*—Equivalent thickness is defined as the average thickness of solid material in the unit and is calculated as follows:

$$T_e, \text{ in.} = [V_n / (L \times H)] \times 1728 \quad (\text{A2.1})$$

$$T_e, \text{ mm} = [V_n / (L \times H)]$$

where:

$T_e$  = equivalent thickness, in. (mm),

$V_n$  = average net volume of full-size units, ft<sup>3</sup> (mm<sup>3</sup>) (see 9.4),

$L$  = average length of full-size units, in. (mm) (see A2.2.1), and

$H$  = average height of full-size units, in. (mm) (see A2.2.1).

A2.5.2.1 Equivalent thickness shall only be calculated and reported for full-size concrete brick.

### A2.6 Report

A2.6.1 Test reports shall include all of the information in Section 10 and the following:

A2.6.2 The gross area compressive strength to the nearest 10 psi (0.1 MPa) separately for each specimen and as the average for three specimens as determined by 9.6.2.

A2.6.3 The absorption results to the nearest 0.1 pcf (1 kg/m<sup>3</sup>) and density results to the nearest 0.1 pcf (1 kg/m<sup>3</sup>) separately for each unit and as the average for the three units as determined by 9.1 and 9.3. If absorption tests are performed on specimens other than full-size units, report the reason for testing reduced-size units and the size and configuration of the specimens tested.

A2.6.4 The average width, height, and length to the nearest 0.1 in. (2.5 mm) of each specimen as determined by A2.2.1.

A2.6.5 For cored units, the minimum distance from the edge of the brick to the nearest core to the nearest 0.1 in. (2.5 mm) as an average of three specimens as determined by A2.2.2.

A2.6.6 The equivalent thickness as an average for three specimens as determined by A2.5.2, when required.

A2.6.7 The moisture content to the nearest 0.1 % as an average for three specimens as determined by 9.2, when required.

A2.6.8 The time at which moisture content is determined (when  $W_r$  is measured).

### A3. TEST PROCEDURES FOR SEGMENTAL RETAINING WALL UNITS

#### A3.1 Scope

A3.1.1 This annex includes testing requirements that are particular for segmental retaining wall units that are manufactured for compliance with the following unit specifications: C 1372.

#### A3.2 Measurement of Dimensions

A3.2.1 For each unit, measure with a steel scale or caliper and record the width ( $W$ ) across the top and bottom bearing surfaces at mid-length, height ( $H$ ) at mid-length of each face, and length ( $L$ ) at mid-height of each face.

#### A3.3 Compressive Strength Testing

A3.3.1 *Test Specimens*—Specimens shall be a saw-cut coupon with an aspect ratio (height divided by its least lateral dimension,  $h/t$ ) of  $2.0 \pm 0.1$  before capping and length to thickness ratio ( $l/t$ ) of  $4.0 \pm 0.1$ . The coupon width shall be as close to 2 in. as possible, but in no case less than 1.5 in. (37 mm). Coupon dimensions shall not differ by more than  $1/8$  in. (3 mm) from the targeted dimension. The compressive strength of the coupon shall be considered to be the compressive strength of the whole unit. Saw-cutting shall be performed in accordance with 7.2.4 and 7.2.5.

NOTE A3.1—The compressive strength of coupons saw-cut from segmental retaining wall units can be measurably influenced by the unit configuration, location of sample, and size of sample. Therefore, for the purposes of comparing compressive strength results between indepen-

dently performed tests, suppliers should be consulted for the recommended coupon sample location and size.

A3.3.2 *Testing*—Cap and test specimens in accordance with 7.3 and 7.4.

#### A3.4 Absorption Testing

A3.4.1 perform absorption tests in accordance with 8.3.

#### A3.5 Calculations

A3.5.1 Calculate absorption, density, net area, and net area compressive strength in accordance with Section 9.

#### A3.6 Report

A3.6.1 Test reports shall include all of the information in Section 10 and the following:

A3.6.2 The net area compressive strength to the nearest 10 psi (0.1 MPa) separately for each specimen and as the average for three specimens as determined by 9.6.1.

A3.6.3 The absorption results to the nearest 0.1 pcf (1 kg/m<sup>3</sup>) and density results to the nearest 0.1 pcf (1 kg/m<sup>3</sup>) separately for each unit and as the average for the three units as determined by 9.1 and 9.3. If absorption tests are performed on specimens other than full-size units, report the reason for testing reduced-size units and the size and configuration of the specimens tested.

A3.6.4 The average width, height, and length to the nearest 0.1 in. (2.5 mm) of each specimen as determined by A3.2.1.

### A4. TEST PROCEDURES FOR CONCRETE INTERLOCKING PAVING UNITS

#### A4.1 Scope

A4.1.1 This annex includes testing requirements that are particular for concrete interlocking paving units that are manufactured for compliance with the following unit specifications: C 936.

#### A4.2 Measurement of Dimensions

A4.2.1 For each unit, measure with a steel scale or caliper and record the width ( $W$ ) across the top and bottom bearing surfaces at mid-length, thickness ( $T$ ) at mid-length of each face, and length ( $L$ ) at mid-height of each face.

A4.2.2 Disregard spacer tabs when performing length and width measurements.

A4.2.3 Disregard chamfers when performing thickness measurements.

#### A4.3 Compressive Strength Testing

A4.3.1 *Test Specimens*—Specimens shall be full-sized units except as modified in A4.3.1.1.

A4.3.1.1 When compression testing full-sized units that are too large for the test machine's bearing block and platens or are beyond the load capacity of the test machine, saw-cut the unit



in half along the shortest axis and one half shall be tested. Units with protruding, smaller ends shall have the ends saw cut and the remaining larger pieces tested. The specimen shall be symmetrical about two axes.

A4.3.2 *Testing*—Cap and test specimens in accordance with 7.3 and 7.4.

#### A4.4 Absorption Testing

A4.4.1 Perform absorption tests in accordance with 8.3.

#### A4.5 Calculations

A4.5.1 Calculate absorption, density, net area, and net area compressive strength in accordance with Section 9.

#### A4.6 Report

A4.6.1 Test reports shall include all of the information in Section 10 and the following:

A4.6.2 The net area compressive strength to the nearest 10 psi (0.1 MPa) separately for each specimen and as the average for three specimens as determined by 9.6.1.

A4.6.3 The absorption results to the nearest 0.1 % and density results to the nearest 0.1 pcf (1 kg/m<sup>3</sup>) separately for each unit and as the average for the three units as determined by 9.1 and 9.3. If absorption tests are performed on specimens other than full-size units, report the reason for testing reduced-size units and the size and configuration of the specimens tested.

A4.6.4 The average width, thickness, and length to the nearest 0.1 in. (2.5 mm) of each specimen as determined by A4.2.1.

### A5. TEST PROCEDURES FOR CONCRETE GRID PAVING UNITS

#### A5.1 Scope

A5.1.1 This annex includes testing requirements that are particular for concrete grid paving units that are manufactured for compliance with the following unit specifications: C 1319.

#### A5.2 Measurement of Dimensions

A5.2.1 For each unit, measure with a steel scale or caliper and record the width (*W*) across the top and bottom bearing surfaces at mid-length, height (*H*) at mid-length of each face, and length (*L*) at mid-height of each face.

A5.2.2 For each unit, measure the web width with a caliper at the thinnest point of each such element and along the height of the web. Disregard grooves, scores, and similar details in the measurements.

#### A5.3 Compressive Strength Testing

A5.3.1 *Test Specimens*—Specimens shall be full-sized units except as modified in A5.3.1.1.

A5.3.1.1 When compression testing full-sized units that are too large for the test machine's bearing block and platens or are beyond the load capacity of the test machine, saw-cut the units to properly size them to conform to the capabilities of the testing machine. The resulting specimen shall have no projections or irregular features and shall be fully enclosed in a four-sided cell or cells. The compressive strength of the segment shall be considered to be the compressive strength of the whole unit.

A5.3.2 *Testing*—Cap and test specimens in accordance with 7.3 and 7.4.

#### A5.4 Absorption Testing

A5.4.1 Perform absorption tests in accordance with 8.3.

#### A5.5 Calculations

A5.5.1 Calculate absorption, density, net area, and net area compressive strength in accordance with Section 9.

#### A5.6 Report

A5.6.1 Test reports shall include all of the information in Section 10 and the following:

A5.6.2 The net area compressive strength to the nearest 10 psi (0.1 MPa) separately for each specimen and as the average for three specimens as determined by 9.6.1.

A5.6.3 The absorption results to the nearest 0.1 pcf (1 kg/m<sup>3</sup>) and to the nearest 0.1 % and density results to the nearest 0.1 pcf (1 kg/m<sup>3</sup>) separately for each unit and as the average for the three units as determined by 9.1 and 9.3. If absorption tests are performed on specimens other than full-size units, report the reason for testing reduced-size units and the size and configuration of the specimens tested.

A5.6.4 The average width, height, and length to the nearest 0.1 in. (2.5 mm) of each specimen as determined by A5.2.1.

A5.6.5 The minimum and average web width to the nearest 0.01 in. (0.25 mm) of each specimen as determined by A5.2.2.

A6. TEST PROCEDURES FOR CONCRETE ROOF PAVERS

A6.1 Scope

A6.1.1 This annex includes testing requirements that are particular for concrete roof pavers that are manufactured for compliance with the following unit specifications: C 1491.

A6.2 Measurement of Dimensions

A6.2.1 For each unit, measure with a steel scale or caliper and record the width (*W*) across the top and bottom bearing surfaces at mid-length, height (*H*) at mid-length of each face, and length (*L*) at mid-height of each face.

A6.3 Compressive Strength Testing

A6.3.1 For concrete roof paver compressive strength tests, cut three test specimens from three whole paver units. Each specimen shall consist of a strip of paver with specimen height equal to specimen width. Where a unit contains supporting ribs, obtain specimens by cutting perpendicular to the direction of the ribs so as to avoid inclusion of bevelled or recessed surfaces at top or bottom edges (see Fig. A6.1).

A6.3.2 *Testing*—Cap and test specimens in accordance with 7.3 and 7.4.

A6.4 Absorption Testing

A6.4.1 Perform absorption tests in accordance with 8.3.

A6.5 Flexural Load Testing

A6.5.1 Three full-sized units shall be tested.

A6.5.2 *Capping*—Units with wearing (top) surfaces containing recesses or other irregularities shall have such recesses capped flush with the uppermost surface in accordance with Practice C 1552.

A6.5.3 *Testing*—The testing arrangement shall be as shown in Fig. A6.2. The load from the upper bearing block of the testing machine shall be applied through the centroid of the concrete roof paver by the bearing assembly illustrated. The flexural length of the paver unit is taken as the end-to-end plan

dimension of the units. Loading shall be applied at a uniform rate such that the total load is applied in not less than 1 min and not less than 3 min.

A6.6 Calculations

A6.6.1 Calculate absorption, density, net area, and net area compressive strength in accordance with Section 9.

A6.6.2 *Ballast Weight*—For concrete roof pavers, calculate ballast weight as follows:

$$W_b(\text{lb/ft}^2) = (W_d)/(A_g) \times 144 \quad (\text{A6.1})$$

$$W_b(\text{kg/m}^2) = (W_d)/(A_g) \times 10^6$$

where:

$W_b$  = ballast weight, lb/ft<sup>2</sup> (kg/m<sup>2</sup>),

$W_d$  = oven-dry weight of unit, lb (kg) (see 8.3.2), and

$A_g$  = gross area of unit, in.<sup>2</sup> (mm<sup>2</sup>) (see 9.5).

A6.7 Report

A6.7.1 Test reports shall include all of the information in Section 10 and the following:

A6.7.2 The net area compressive strength to the nearest 10 psi (0.1 MPa) separately for each specimen and as the average for three specimens as determined by 9.6.1.

A6.7.3 The absorption results to the nearest 0.1 pcf (1 kg/m<sup>3</sup>) and density results to the nearest 0.1 pcf (1 kg/m<sup>3</sup>) separately for each unit and as the average for the three units as determined by 9.1 and 9.3. If absorption tests are performed on specimens other than full-size units, report the reason for testing reduced-size units and the size and configuration of the specimens tested.

A6.7.4 The average width, height, and length to the nearest 0.1 in. (2.5 mm) of each specimen as determined by A6.2.1.

A6.7.5 The flexural load to the nearest 1 lb (5 N) required to fail a unit separately and as an average for three units.

A6.7.6 Ballast weight to the nearest 1 psf (5 kg/m<sup>2</sup>) as an average of the three specimens.

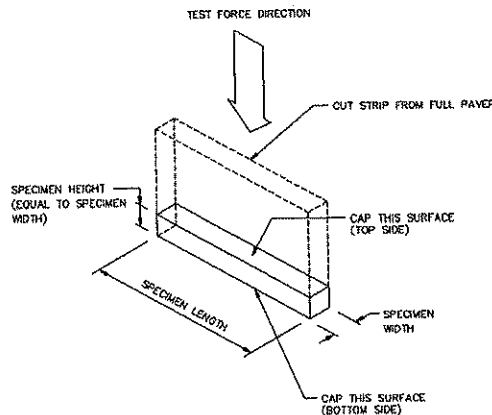

FIG. A6.1 Compressive Strength Test Setup for Concrete Roof Pavers

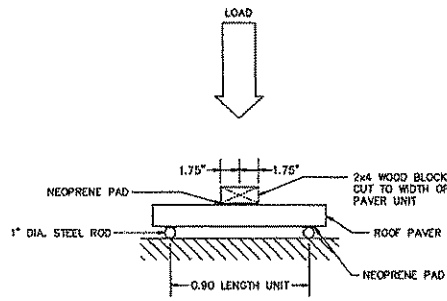

FIG. A6.2 Flexural Strength Test Setup for Concrete Roof Pavers

**A7. DETERMINING PLATE THICKNESS REQUIREMENTS FOR COMPRESSION TESTING**

**A7.1 Scope**

A7.1.1 This annex provides additional information to assist in determining the plate thickness requirements for compression testing as written in 7.1.

**A7.2 Terminology**

A7.2.1 Fig. A7.1 shows the location of the referenced test equipment as used in the compression testing of units.

**A7.3 Determining the Diameter of the Upper Platen**

A7.3.1 As shown in Fig. A7.2, the diameter of the upper platen is considered in this test method to be equal to the maximum horizontal dimension measured across the circle created by the spherical portion of the upper platen (this measured diameter may differ from the actual geometric diameter of the sphere based on its curvature). If the upper platen includes a nonspherical section that was manufactured integrally with the spherical head from a single piece of steel, the diameter of the upper platen is considered to be the diameter of the spherical seat on the upper surface of the upper platen plus the thickness of the nonspherical section ( $t_{PL}$ ). However, the diameter of the upper platen shall not be greater than the minimum horizontal dimension of the upper platen.

**A7.4 Distance from the Edge of Platen to Furthestmost Corner of Test Specimen (See Fig. A7.3)**

A7.4.1 Determine the distance from the edge of the platen to the furthestmost corner of the specimen as follows:

A7.4.2 Locate the specimen's center of mass, and mark it on top of the specimen.

A7.4.3 Determine to the nearest 1/8 in. (3 mm) the distance from the center of mass of the specimen to the furthestmost corner or edge of the test specimen. Record this distance as  $A$ .

A7.4.4 The distance from the platen to the furthestmost corner of the test specimen is obtained by the following equation:

$$d = A - \left(\frac{D_{PL}}{2}\right) \tag{A7.1}$$

where:

- $d$  = distance from the platen to the furthestmost corner of the test specimen, in. (mm),
- $A$  = distance from the center of mass of the specimen to the furthestmost corner of the test specimen, in. (mm), and
- $D_{PL}$  = calculated diameter of the upper platen, in. (mm).

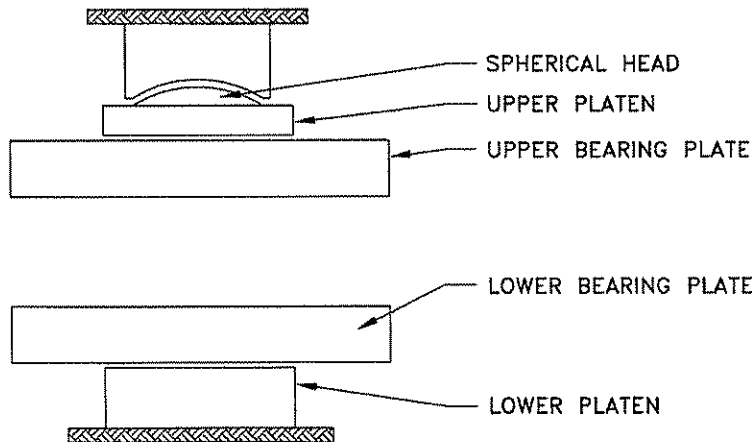
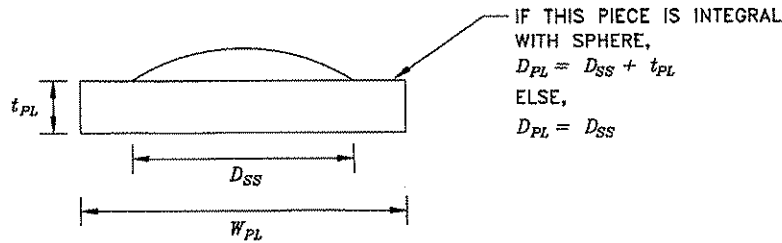

FIG. A7.1 Equipment Used for Compression Testing



where:

- $D_{SS}$  = measured diameter of spherical seat,
- $D_{PL}$  = calculated diameter of upper platen,
- $W_{PL}$  = measured minimum width of upper platen, and
- $t_{PL}$  = measured thickness of nonspherical section of upper platen.

FIG. A7.2 Diameter of the Upper Platen

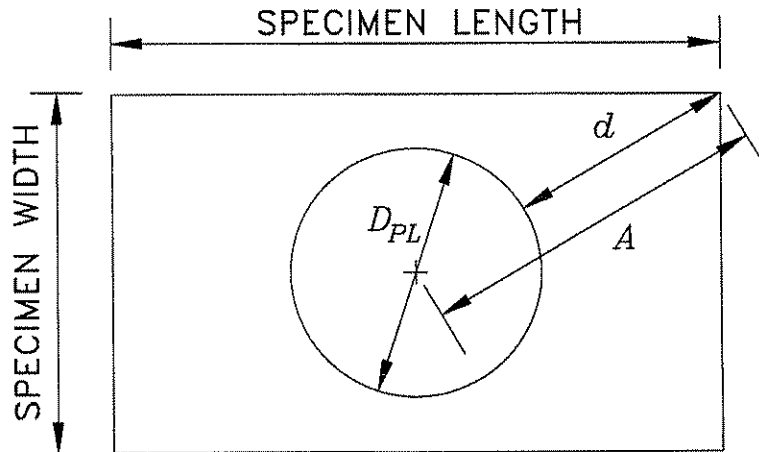

FIG. A7.3 Distance from Platen to Furthest Corner of Test Specimen

## APPENDIX

(Nonmandatory Information)

### X1. WORKSHEET AND TEST REPORT FOR CONCRETE MASONRY UNITS

X1.1 Included in this section is a sample laboratory worksheet and a test report form. These samples were developed for use in recording and reporting test information for conventional concrete masonry units to determine their compliance with Specification C 90. These forms are to be used as

guidelines only. Users of these test methods may use or modify these forms to suit their purposes and to address the requirements of the test methods as they apply to the specific specimens being tested.

|   |   |                      |       |                         |
|---|---|----------------------|-------|-------------------------|
| <b>ASTM C 140 Worksheet</b>   |   | Lab Proj. No.: _____ |       |                         |
|   |   | Date Received: _____ |       |                         |
|   |   | Report Date: _____   |       |                         |
| Client: _____   | Testing Agency: _____                         |                      |       |                         |
| Address: _____  | Address: _____                                |                      |       |                         |
| _____   | _____   |                      |       |                         |
| Job No./Description: _____  | Sampling Party: _____                         |                      |       |                         |
| Unit Designation/Description: _____   | Overall Nominal Dimensions: Width (in.) _____ |                      |       |                         |
| _____   | Height (in.) _____                            |                      |       |                         |
| _____   | Length (in.) _____                            |                      |       |                         |
| <b>Compression Units</b>  |   |                      |       |                         |
| (Determine the following information for each of the three units to be tested in compression.)                    |   |                      |       |                         |
| Specimen:   | #1  | #2                   | #3    |                         |
| Received Weight ( $W_R$ )   | _____   | _____                | _____ | lb. Date _____ By _____ |
| Max. Compressive Load ( $P_{MAX}$ )   | _____   | _____                | _____ | lb. Date _____ By _____ |
| <b>Absorption Units</b>   |   |                      |       |                         |
| (Determine the following information for each of the three units to be immersed in water for absorption testing.) |   |                      |       |                         |
| Specimen:   | #4  | #5                   | #6    |                         |
| Width (W) @ Top   | _____   | _____                | _____ | in.                     |
| @ Bottom  | _____   | _____                | _____ | in.                     |
| Height (H) @ Face 1   | _____   | _____                | _____ | in.                     |
| @ Face 2  | _____   | _____                | _____ | in.                     |
| Length (L) @ Face 1   | _____   | _____                | _____ | in. Measurements...     |
| @ Face 2  | _____   | _____                | _____ | in. Date _____ By _____ |
| Faceshell Thickness (FST)   |   |                      |       |                         |
| @ Face 1  | _____   | _____                | _____ | in.                     |
| @ Face 2  | _____   | _____                | _____ | in.                     |
| Web Thickness (WT)  |   |                      |       |                         |
| @ Web 1   | _____   | _____                | _____ | in.                     |
| @ Web 2   | _____   | _____                | _____ | in.                     |
| @ Web 3   | _____   | _____                | _____ | in.                     |
| @ Web 4   | _____   | _____                | _____ | in.                     |
| Received Weight ( $W_a$ )   | _____   | _____                | _____ | lb. Date _____ By _____ |
| Immersed Weight ( $W_i$ )   | _____   | _____                | _____ | lb.                     |
| Saturated Weight ( $W_s$ )  | _____   | _____                | _____ | lb. Date _____ By _____ |
| Final Oven-Dry Weight ( $W_o$ )   | _____   | _____                | _____ | lb. Date _____ By _____ |
| Intermediate Drying Weights (first reading after at least 24 hours drying, successive readings at 2 hr intervals) |   |                      |       |                         |
| 1st   | _____   | _____                | _____ | lb. Time _____          |
| 2nd   | _____   | _____                | _____ | lb. Time _____          |
| 3rd   | _____   | _____                | _____ | lb. Time _____          |

FIG. X1.1 Worksheet

|                                     |                            |                    |
|-------------------------------------|----------------------------|--------------------|
| <b>ASTM C 140 Test Report</b>       |                            | Job No.: _____     |
|                                     |                            | Report Date: _____ |
| Client: _____                       | Testing Agency: _____      |                    |
| Address: _____                      | Address: _____             |                    |
| _____                               | _____                      |                    |
| Unit Specification: _____           | Sampling Party: _____      |                    |
| Unit Designation/Description: _____ | Job No./Description: _____ |                    |
| _____                               | _____                      |                    |
| _____                               | _____                      |                    |

**Summary of Test Results**

| Physical Property          | Specified Values | Average Test Results | Units | Physical Property               | Specified Values | Average Test Results | Units           |
|----------------------------|------------------|----------------------|-------|---------------------------------|------------------|----------------------|-----------------|
| Net Compressive Strength   | ****             | -----                | psi   | Min. Faceshell Thickness (FST)  | ****             | -----                | in.             |
| Gross Compressive Strength | ****             | -----                | psi   | Min. Web Thickness (WT)         | ****             | -----                | in.             |
| Density                    | ****             | -----                | pcf   | Equivalent Web Thickness        | ****             | -----                | in.             |
| Absorption                 | ****             | -----                | pcf   | Equivalent Thickness            | ****             | -----                | in.             |
| Percent Solid              | ****             | -----                | %     | Max. Var. from Spec. Dimensions | ****             | -----                | in.             |
| Moisture Content           | ****             | -----                | %     | Net Cross-Sectional Area        | ****             | -----                | in <sup>2</sup> |
|                            |                  |                      |       | Gross Cross-Sectional Area      | ****             | -----                | in <sup>2</sup> |

**Individual Unit Test Results**

|                          | Specimen No. | Received           |       | Cross-Sectional Area |                 | Max. Load | Compressive Strength |       |
|--------------------------|--------------|--------------------|-------|----------------------|-----------------|-----------|----------------------|-------|
|                          |              | Wt, W <sub>R</sub> |       | Gross                | Net*            |           | Gross                | Net   |
|                          |              | lb                 |       | in <sup>2</sup>      | in <sup>2</sup> | lb        | psi                  | psi   |
| <i>Compression Units</i> | #1           | -----              | ----- | -----                | -----           | -----     | -----                | ----- |
|                          | #2           | -----              | ----- | -----                | -----           | -----     | -----                | ----- |
|                          | #3           | -----              | ----- | -----                | -----           | -----     | -----                | ----- |
|                          | Average      | -----              | ----- | -----                | -----           | -----     | -----                | ----- |

\* Net area determined from absorption specimens unless solid units are used.

|                         | Specimen No. | Avg   | Avg    | Avg    | Avg. Min. | Avg. Min. |
|-------------------------|--------------|-------|--------|--------|-----------|-----------|
|                         |              | Width | Height | Length | FST       | WT        |
|                         |              | in.   | in.    | in.    | in.       | in.       |
| <i>Absorption Units</i> | #4           | ----- | -----  | -----  | -----     | -----     |
|                         | #5           | ----- | -----  | -----  | -----     | -----     |
|                         | #6           | ----- | -----  | -----  | -----     | -----     |
|                         | Average      | ----- | -----  | -----  | -----     | -----     |

  

| Specimen No. | Received              |                    | Immersed           | Saturated          | Oven-Dry | Absorp | Density         | Net Volume      | Net Area | Percent Solid         | Moisture Content ** |
|--------------|-----------------------|--------------------|--------------------|--------------------|----------|--------|-----------------|-----------------|----------|-----------------------|---------------------|
|              | Wt, W <sub>R</sub> ** | Wt, W <sub>I</sub> | Wt, W <sub>S</sub> | Wt, W <sub>D</sub> |          |        |                 |                 |          |                       |                     |
|              | lb                    | lb                 | lb                 | lb                 | pcf      | pcf    | ft <sup>3</sup> | in <sup>2</sup> | %        | % of total absorption |                     |
| #4           | -----                 | -----              | -----              | -----              | -----    | -----  | -----           | -----           | -----    | -----                 | -----               |
| #5           | -----                 | -----              | -----              | -----              | -----    | -----  | -----           | -----           | -----    | -----                 | -----               |
| #6           | -----                 | -----              | -----              | -----              | -----    | -----  | -----           | -----           | -----    | -----                 | -----               |
| Average      | -----                 | -----              | -----              | -----              | -----    | -----  | -----           | -----           | -----    | -----                 | -----               |

\*\* Received weight determined at the time of unit delivery to the job site or from units sampled at that time and delivered to the laboratory in sealed containers for moisture content determination.

Signature \_\_\_\_\_  
Name \_\_\_\_\_  
Title \_\_\_\_\_

FIG. X1.2 Test Report

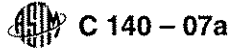

C 140 – 07a

## SUMMARY OF CHANGES

Committee C15 has identified the location of selected changes to this standard since the last issue (C 140 – 07) that may impact the use of this standard. (Approved Dec. 15, 2007.)

(1) Caliper jaw length has been removed from 6.1.2.

(2) The word “scale” was removed from the end of the first sentence in A1.2.1 and “to the nearest division of the scale” was added to the end of A1.2.2.

Committee C15 has identified the location of selected changes to this standard since the last issue (C 140 – 06) that may impact the use of this standard. (Approved July 1, 2007.)

(1) This standard was completely reorganized for the C140–07 edition. Annexes were added to provide specific testing and reporting requirements for certain products to aide

users in understanding appropriate testing procedures for those products and to assist in determining compliance with applicable unit specifications.

*ASTM International takes no position respecting the validity of any patent rights asserted in connection with any item mentioned in this standard. Users of this standard are expressly advised that determination of the validity of any such patent rights, and the risk of infringement of such rights, are entirely their own responsibility.*

*This standard is subject to revision at any time by the responsible technical committee and must be reviewed every five years and if not revised, either reapproved or withdrawn. Your comments are invited either for revision of this standard or for additional standards and should be addressed to ASTM International Headquarters. Your comments will receive careful consideration at a meeting of the responsible technical committee, which you may attend. If you feel that your comments have not received a fair hearing you should make your views known to the ASTM Committee on Standards, at the address shown below.*

*This standard is copyrighted by ASTM International, 100 Barr Harbor Drive, PO Box C700, West Conshohocken, PA 19428-2959, United States. Individual reprints (single or multiple copies) of this standard may be obtained by contacting ASTM at the above address or at 610-832-9585 (phone), 610-832-9555 (fax), or service@astm.org (e-mail); or through the ASTM website (www.astm.org).*



## REPORT OF GROUT COMPRESSIVE STRENGTH (ASTM C1019)

**CLIENT:** Intercontinental Developers Inc.  
 Attn: Mr. Richard Libardoni  
 1270 Soldiers Road  
 Boston, MA 02135-1003

**PROJECT:** Ocean Gateway Garage  
 Portland, ME

**DATE:** January 23, 2008      **REPORT #:** 07-117-040

**General Placement Location:** Elevator Shaft & Stair Well Between G.4 and H Line  
**Specific Placement Location:** Bond Beam Between 3<sup>rd</sup> & 4<sup>th</sup> Level, G.4 Between 2.3 & 2.9  
**Field Representative:** Ken Ries  
**Date Cast:** 01/16/08  
**Date Received:** 01/17/08  
**Design Strength:** 3000 psi  
**Supplier:** Made On-Site

| Materials   | Description    | Batch Quantities     |
|-------------|----------------|----------------------|
| Cement      | Dragon Type II | (2) 94 lb bags       |
| Sand        | Heated         | (8) 5 gallon buckets |
| Lime        |                |                      |
| Water       | Heated         | 13 Gallons           |
| Admixture 1 |                |                      |

| Specimen # | Date Tested | Age (days) | Strength (psi) | Average Strength (psi) |
|------------|-------------|------------|----------------|------------------------|
| 1          | 01/23/08    | 7          | 4020           | 4050                   |
| 2          | 01/23/08    | 7          | 4040           |                        |
| 3          | 01/23/08    | 7          | 4090           |                        |
| 4          | 02/13/08    | 28         |                |                        |
| 5          | 02/13/08    | 28         |                |                        |
| 6          | 02/13/08    | 28         |                |                        |
| 7          |             | H          |                |                        |
| 8          |             | H          |                |                        |

**Remarks:**

NH ME MA

CONSULTJTC.COM

### JOHN TURNER CONSULTING, INC.

19 DOVER STREET  
 DOVER NH 03820  
 T 603.749.1841 F 603.516.6851

1950 LAFAYETTE ROAD, BOX 11  
 PORTSMOUTH NH 03801  
 T 603.610.7104 F 603.610.7108

6 CLINTON AVENUE  
 WESTFIELD MA 01085  
 T 413.642.0138 F 413.642.0164  
 DBA MASS CONSULTING SERVICES

15 HOLLY STREET, UNIT 103  
 SCARBOROUGH ME 04074  
 T 207.833.7878 F 207.883.3365





## REPORT OF GROUT COMPRESSIVE STRENGTH (ASTM C1019)

**CLIENT:** Intercontinental Developers Inc.  
 Attn: Mr. Richard Libardoni  
 1270 Soldiers Road  
 Boston, MA 02135-1003

**PROJECT:** Ocean Gateway Garage  
 Portland, ME

**DATE:** December 26, 2007                      **REPORT #:** 07-117-030

**General Placement Location:** Bond Beam At First Floor  
**Specific Placement Location:** G.4 Between 3 & 2.9  
**Field Representative:** Ken Ries  
**Date Cast:** 11/28/07  
**Date Received:** 11/29/07  
**Design Strength:** 3000 psi  
**Supplier:** Made On-Site

| Materials   | Description | Batch Quantities     |
|-------------|-------------|----------------------|
| Cement      |             | 94 lbs               |
| Sand        |             | (6) 5 gallon buckets |
| Lime        |             |                      |
| Water       |             | 9 gallons            |
| Admixture 1 |             |                      |

| Specimen # | Date Tested | Age (days) | Strength (psi) | Average Strength (psi) |
|------------|-------------|------------|----------------|------------------------|
| 1          | 12/05/07    | 7          | 2090           | 2070                   |
| 2          | 12/05/07    | 7          | 2030           |                        |
| 3          | 12/05/07    | 7          | 2080           |                        |
| 4          | 12/26/07    | 28         | 3770           | 3850                   |
| 5          | 12/26/07    | 28         | 3840           |                        |
| 6          | 12/26/07    | 28         | 3930           |                        |
| 7          |             | H          |                |                        |
| 8          |             | H          |                |                        |

**Remarks:**

NH, ME MA

CONSULTJTC.COM

### JOHN TURNER CONSULTING, INC.

19 DOVER STREET  
 DOVER NH 03820  
 T 603.749.1841 F 603.516.6851

1950 LAFAYETTE ROAD, BOX 11  
 PORTSMOUTH NH 03801  
 T 603.610.7104 F 603.610.7108

6 CLINTON AVENUE  
 WESTFIELD MA 01085  
 T 413.642.0138 F 413.642.0164  
 DBA MASS CONSULTING SERVICES

15 HOLLY STREET, UNIT 103  
 SCARBOROUGH ME 04074  
 T 207.833.7878 F 207.883.3365