

## Features

- Single addressable red LED indicator
- Mounts in a standard 4" or double gang box
- SLC Class A, Class X & Class B
- Wiring terminals accessible when mounted in box
- All wiring terminals accept 22 to 12 AWG
- Product includes a 5 year warranty



## Description

The PAD100-LED uses one (1) SLC loop address when used as an addressable indicator. The module mounts on either a 4" square or double gang box. The PAD100-LED includes one red LED to indicate the modules status. In normal condition, the LED flashes when the device is being polled by the control panel. When activated, the LED will flash at a fast rate.

## Application

The PAD100-LED is compatible with Potter's IPA series addressable fire alarm control panels. The PAD100-LED is an addressable LED module used to provide indication of a variety of system conditions.

## Setting the Address

Each addressable SLC device must be assigned an address. The address is set using the DIP switch located on the PAD100-LED.

Before connecting a device to the SLC loop, take the following precautions to prevent potential damage to the panel or device:

1. Power to the device is removed.
2. Field wiring is correctly installed.
3. Field wiring has no open or short circuits.

## Technical Specifications

|                             |   |
|-----------------------------|---|
| Operating Voltage           | 24.0V   |
| Max SLC Standby Current     | 240 $\mu$ A   |
| Max SLC Alarm Current       | 240 $\mu$ A   |
| Operating Temperature Range | 32°F - 120°F (0° - 49°C)                                      |
| Operating Humidity Range    | 0 to 93% (non-condensing)                                     |
| Max no. of Module Per Loop  | 127 units   |
| Dimensions                  | 4.17" (106mm)L $\times$ 4.17" (106mm)W $\times$ 1.14" (29mm)D |
| Mounting Options            | Standard 4" Square or Double Gang Box                         |
| Shipping Weight             | 0.6 lbs   |

**Installation Using Compatible Electrical Box**

Fig 1

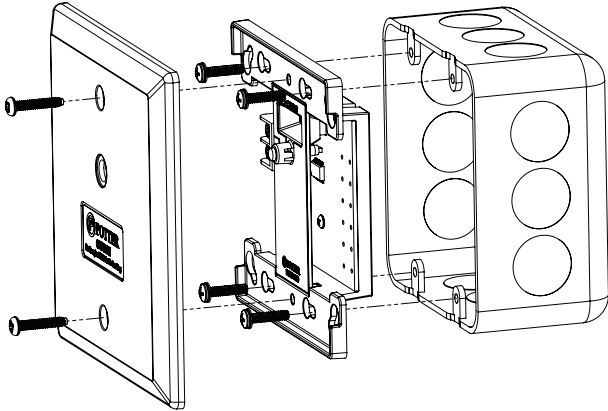

**Wiring Diagram**

PAD100-LED SLC Wiring

Fig 2

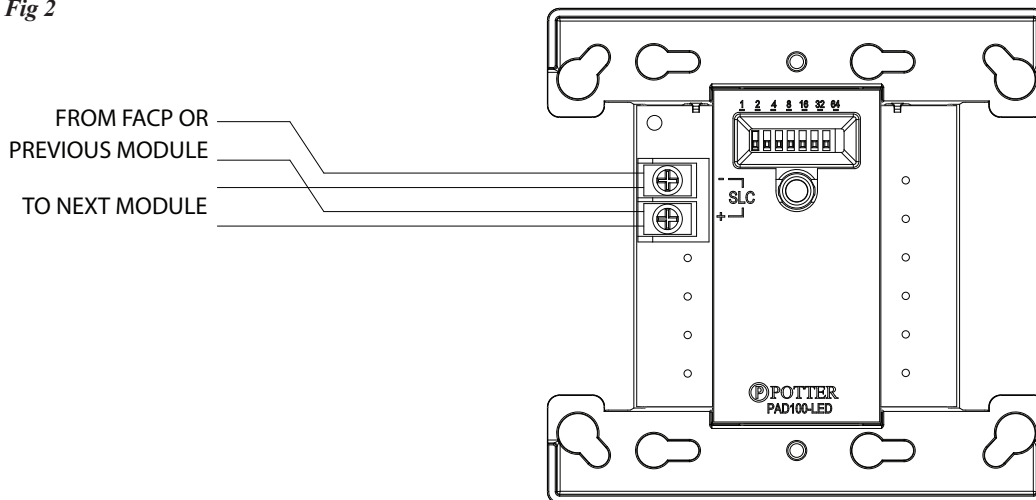

**Ordering Information**

| Model      | Description | Stock No. |
|------------|-------------|-----------|
| PAD100-LED | LED Module  | 3992710   |