

Features

- One (1) Form C relay contact
- SLC Class A, Class X & Class B
- Mounts in a standard 4" or double gang box
- Wiring terminals accessible when mounted in box
- All wiring terminals accept 22 to 12 AWG
- Product includes a 5 year warranty

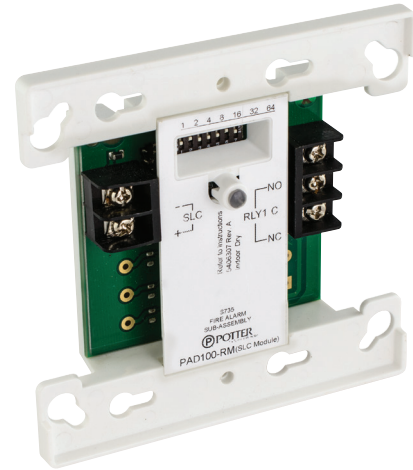

Description

The PAD100-RM uses one (1) SLC loop address to provide one (1) Form C relay contact. The module mounts on either a 4" square or double gang box. The PAD100-RM includes one red LED to indicate the module's status. In normal condition, the LED flashes when the device is being polled by the control panel.

Application

The PAD100-RM is compatible with Potter's IPA series addressable fire alarm control panels. The PAD100-RM is an interface module providing one (1) Form C relay contact.

Setting the Address

Each addressable SLC device must be assigned an address. The address is set using the DIP switch located on the PAD100-RM. The PAD100-RM uses a single device address to identify relay contacts.

Before connecting a device to the SLC loop, take the following precautions to prevent potential damage to the panel or device:

1. Power to the device is removed.
2. Field wiring is correctly installed.
3. Field wiring has no open or short circuits.

Technical Specifications

Operating Voltage	24.0V
Max SLC Standby Current	240 μ A
Max SLC Alarm Current	240 μ A
Relay Contacts	2A @30VDC, 0.5A @125VAC
Operating Temperature Range	32 to 120°F (0 to 49°C)
Operating Humidity Range	0 to 93% (non-condensing)
Max no. of Module Per Loop	127 units
Dimensions	4.17" (106mm)L \times 4.17" (106mm)W \times 1.14" (29mm)D
Mounting Options	Standard 4" Square or Double Gang Box
Shipping Weight	0.6 lbs

Installation Using Compatible Electrical Box

Fig 1

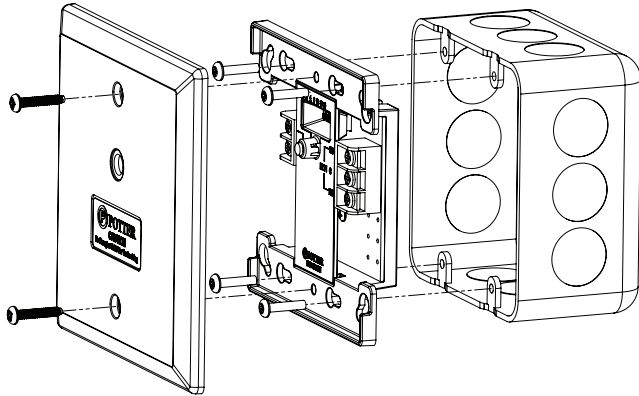

Wiring Diagram

PAD100-RM Relay Circuit

Fig 2

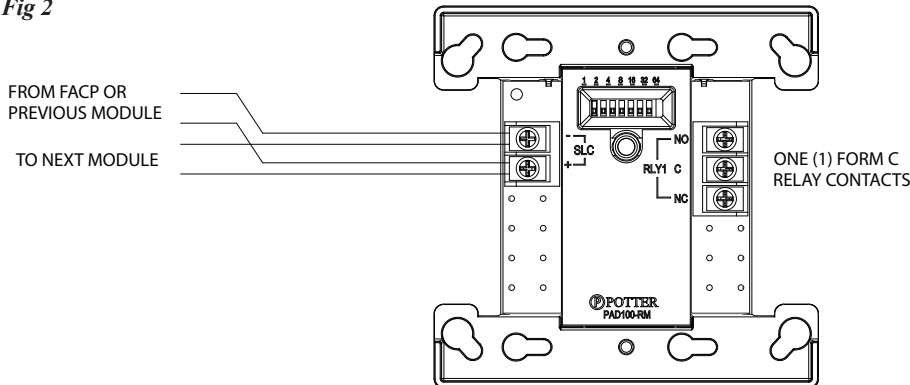

NOTICE

It is possible that the internal relay in the PAD100-RM may be shipped in the non-normal / activated state. To ensure that the internal relay is set to the normal state, connect the module to the SLC loop and reset the control panel before terminating the wiring to the modules output.

Ordering Information

Model	Description	Stock No.
PAD100-RM	Relay Module	3992705