

10 CONNECTION TO EXST. GARAGE - DETAIL 1

3/4" = 1'-0"

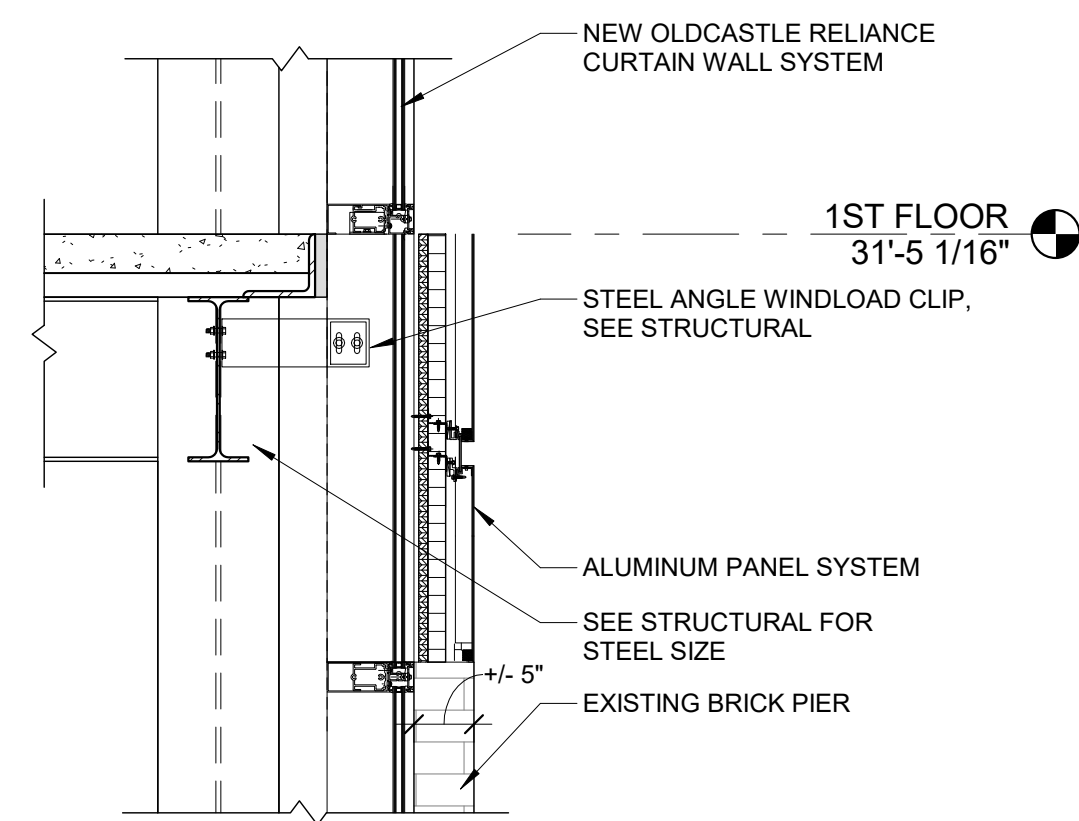

6 CURTAIN WALL - DETAIL 1

3/4" = 1'-0"

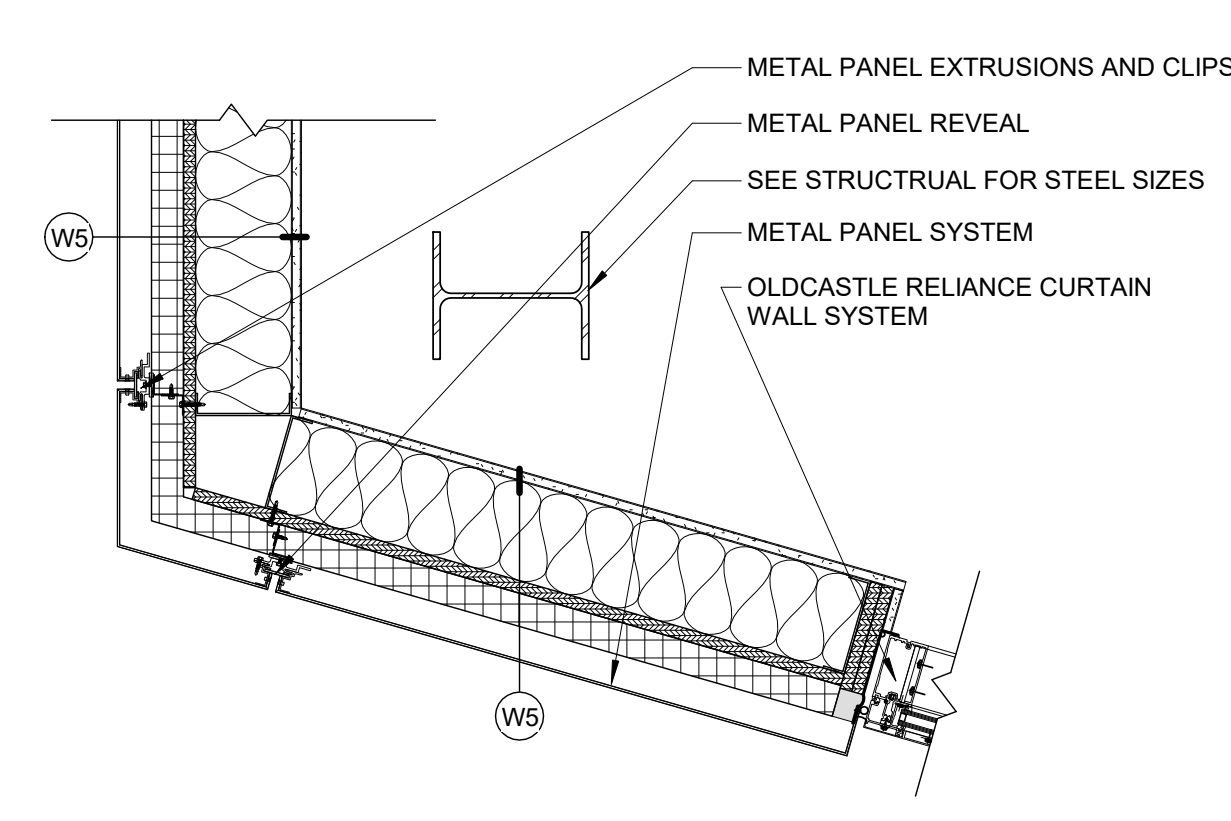

3 COLUMN DETAIL 3

1" = 1'-0"

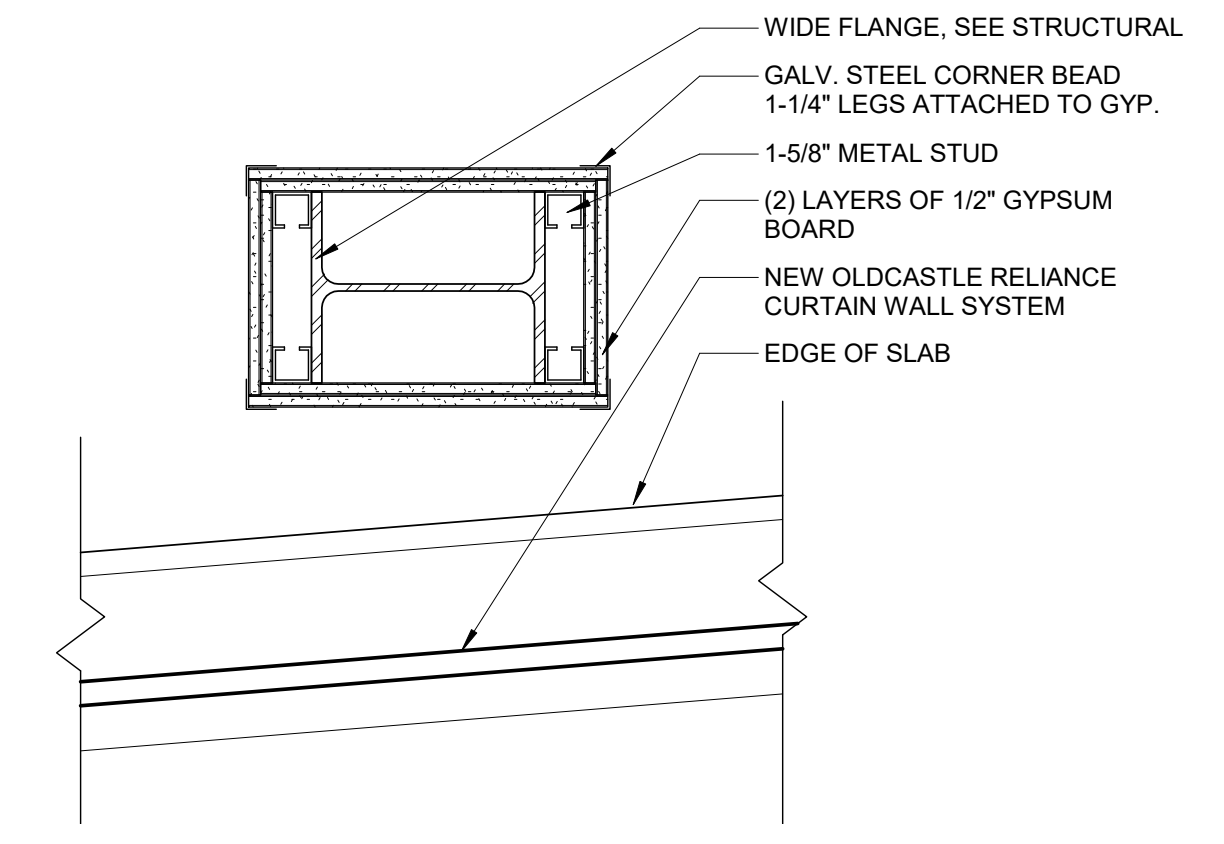

1 COLUMN DETAIL 1

1 1/2" = 1'-0"

COLUMN WRAP - 1HR RATING
UL DESIGN - NO. X528

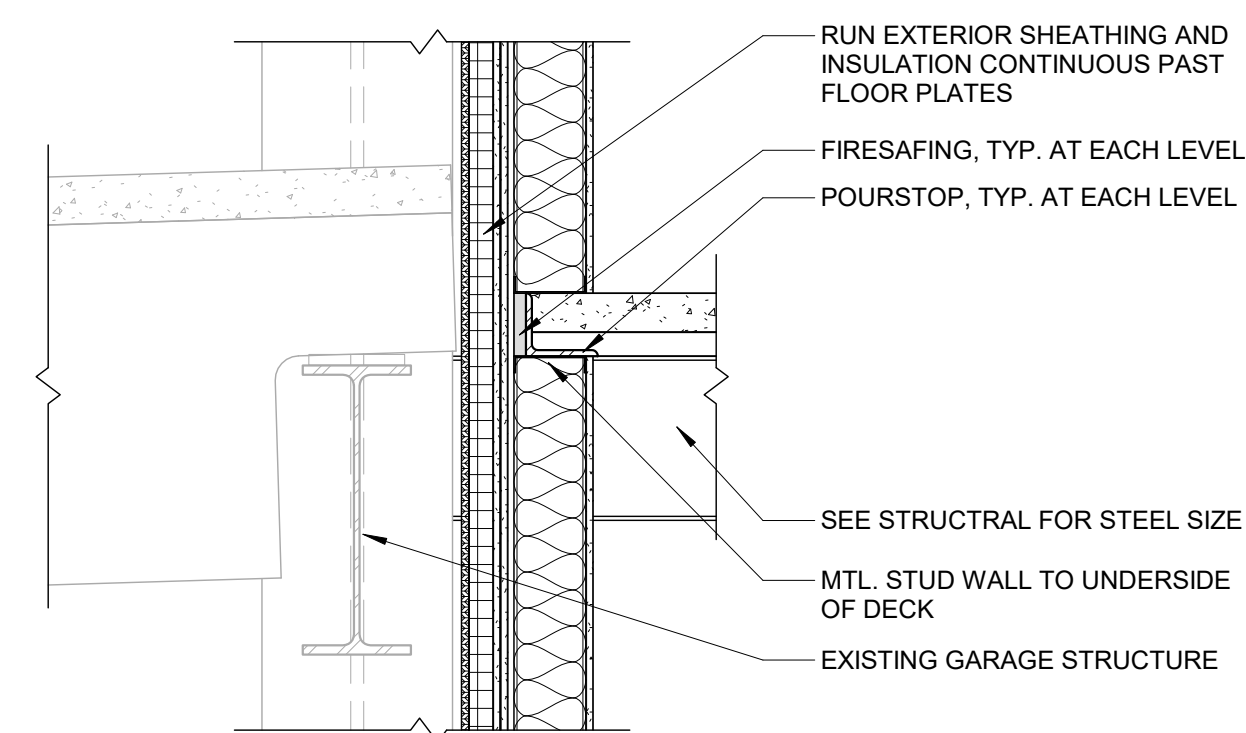

11 CONNECTION TO EXST. GARAGE - DETAIL 2

3/4" = 1'-0"

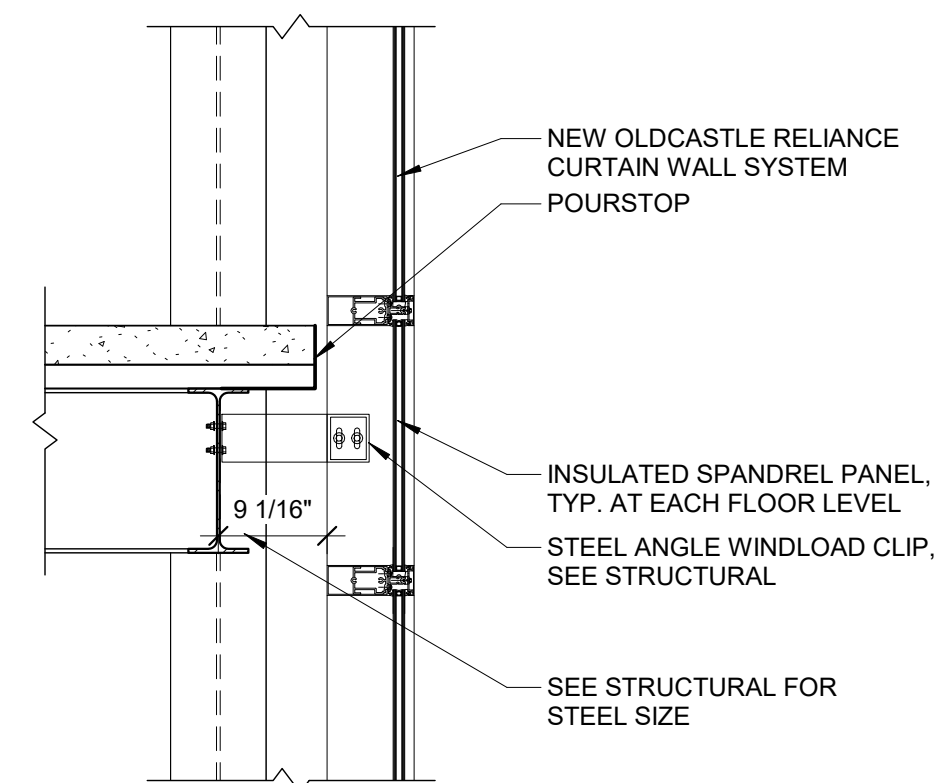

7 CURTAIN WALL - DETAIL 2

3/4" = 1'-0"

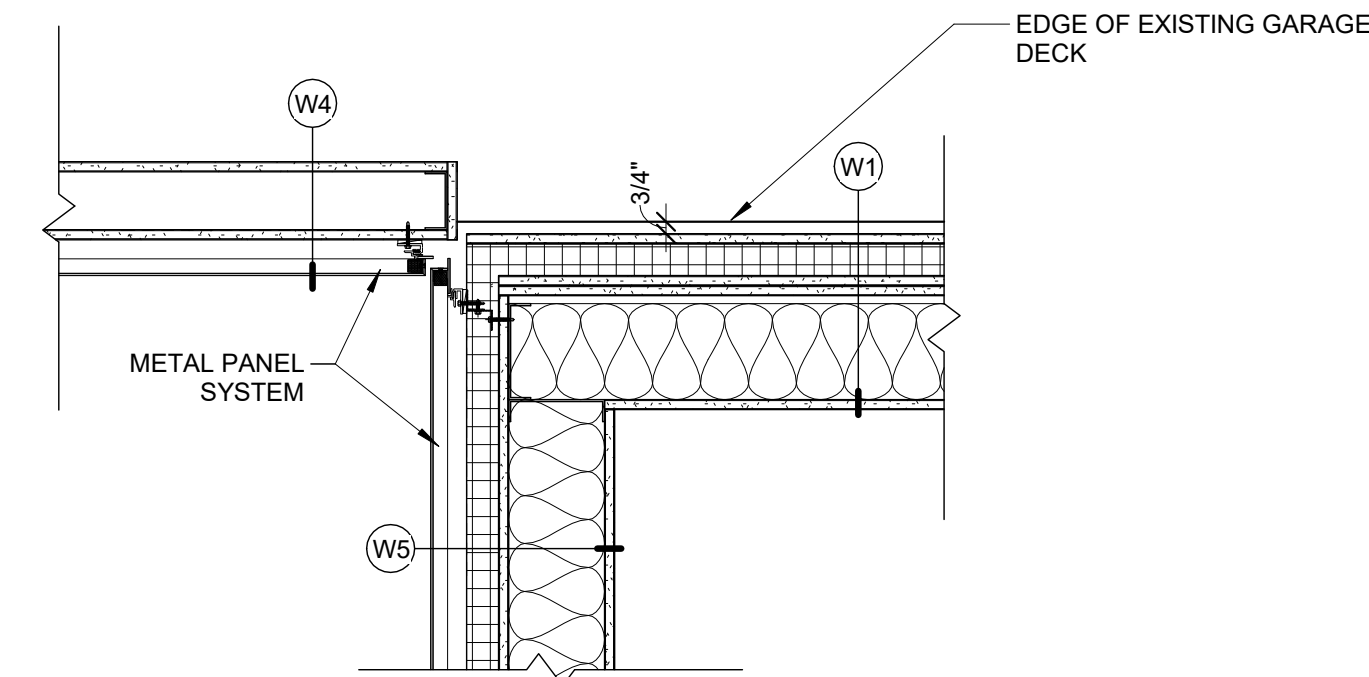

4 CORNER DETAIL

1" = 1'-0"

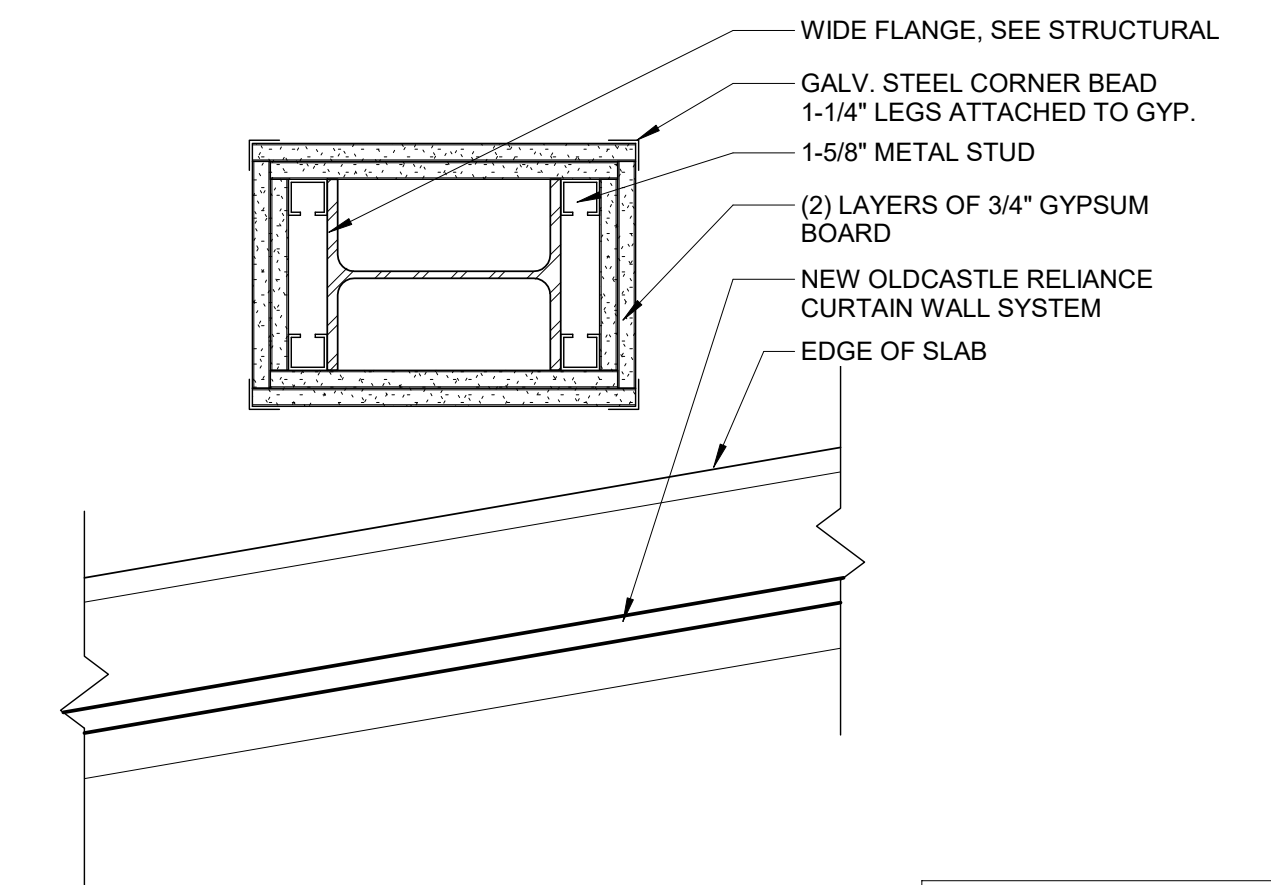

2 COLUMN DETAIL 2

1 1/2" = 1'-0"

COLUMN WRAP - 1HR RATING
UL DESIGN - NO. X528

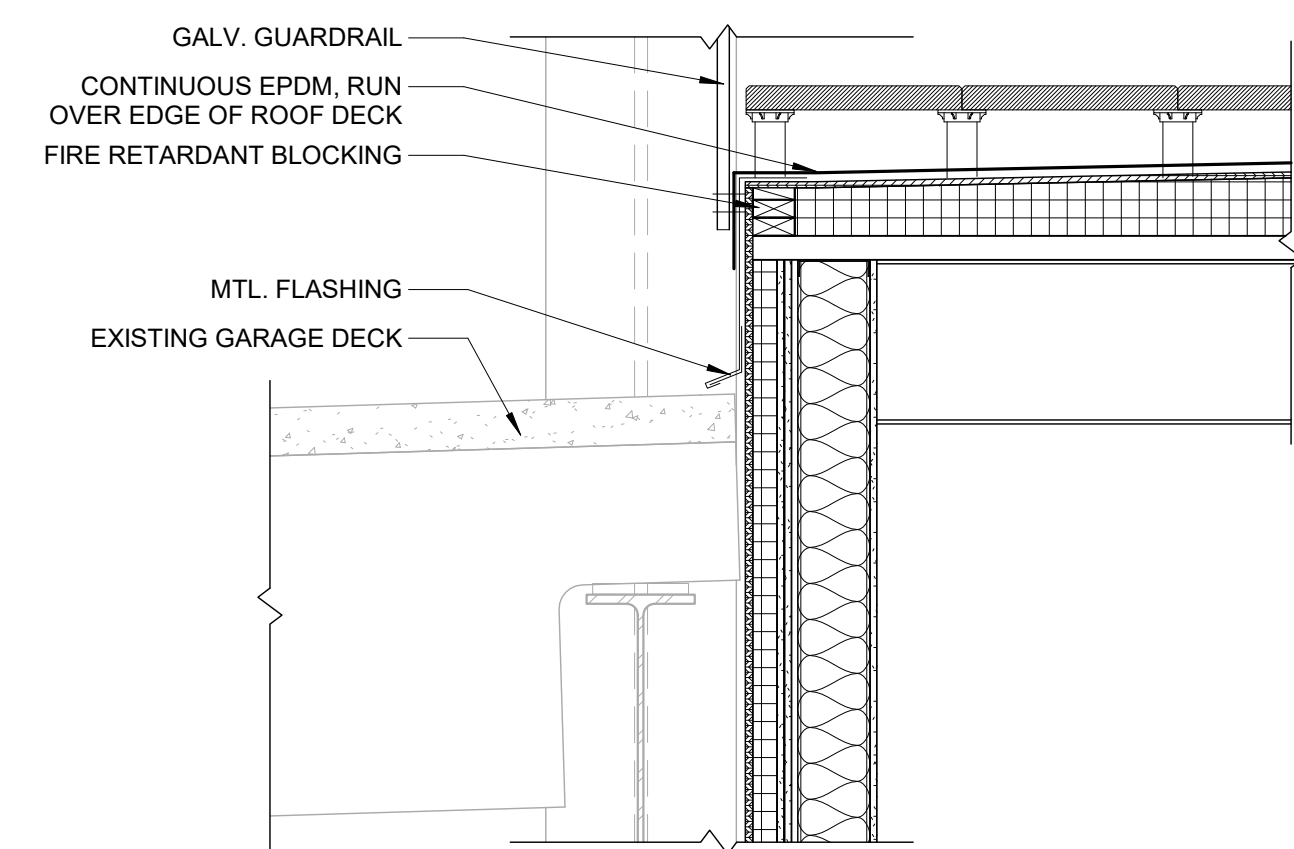

12 CONNECTION TO EXST. GARAGE - DETAIL 3

3/4" = 1'-0"

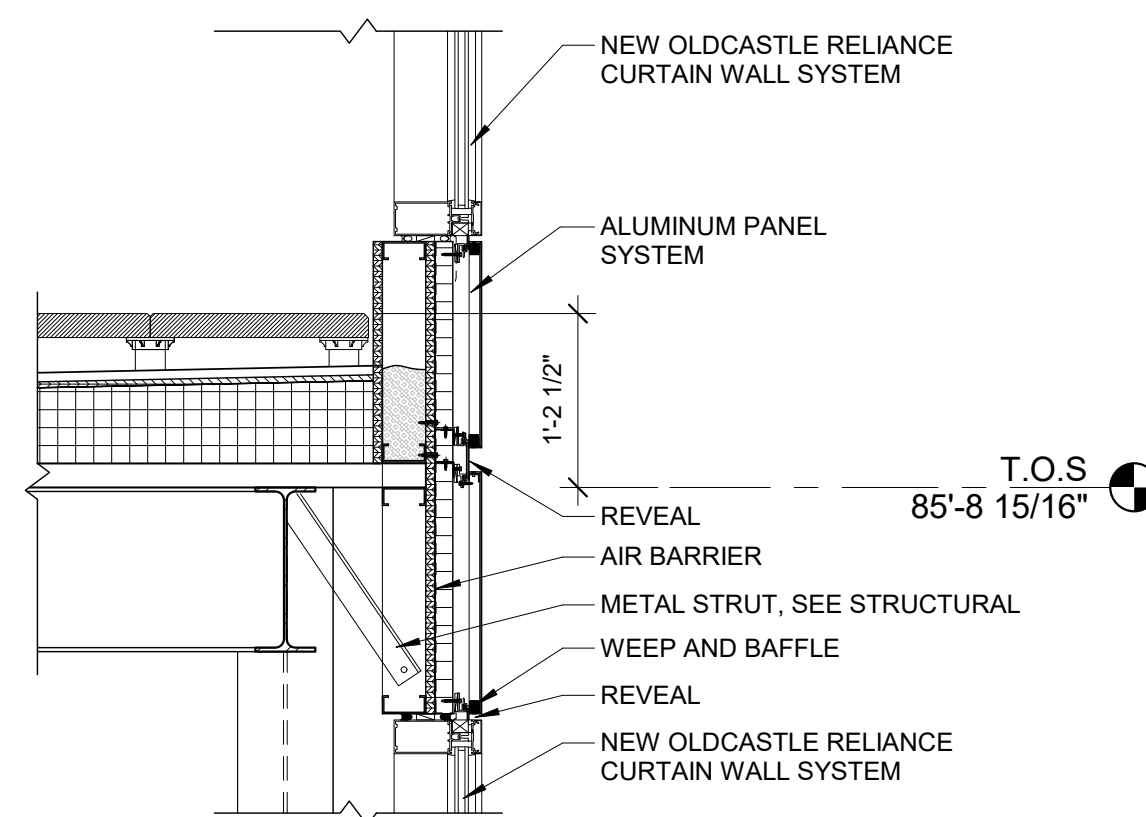

8 CURTAIN WALL - DETAIL 3

3/4" = 1'-0"

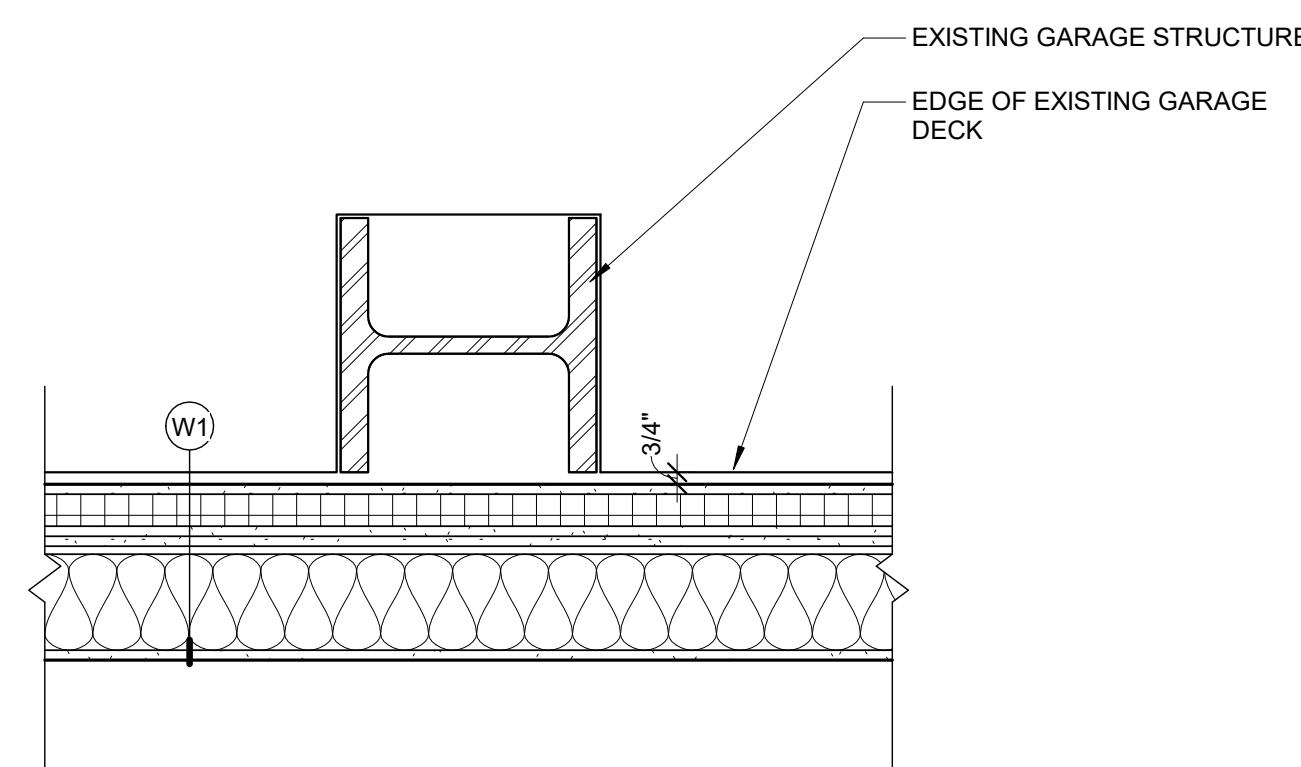

5 COLUMN DETAIL 5

1" = 1'-0"

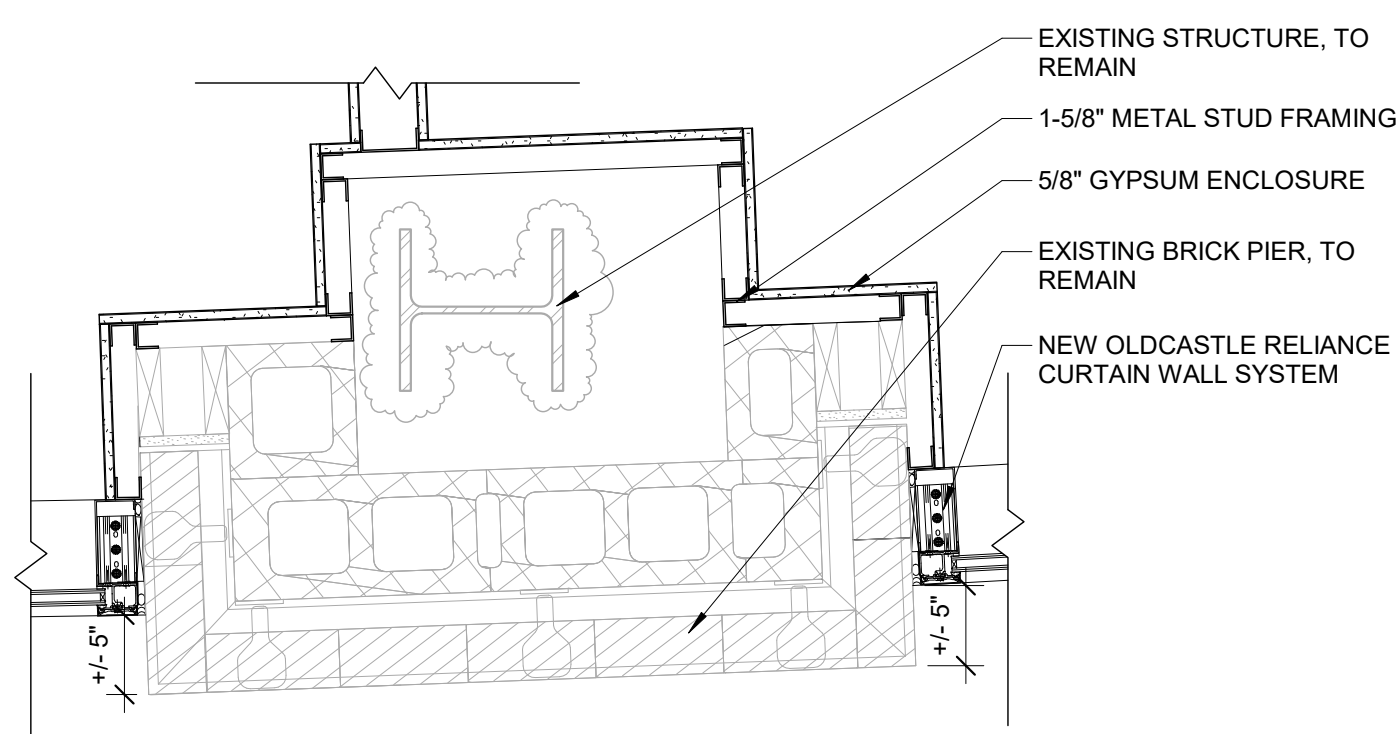

13 EXISTING CLOUMN DETAIL AT LOBBY

1" = 1'-0"

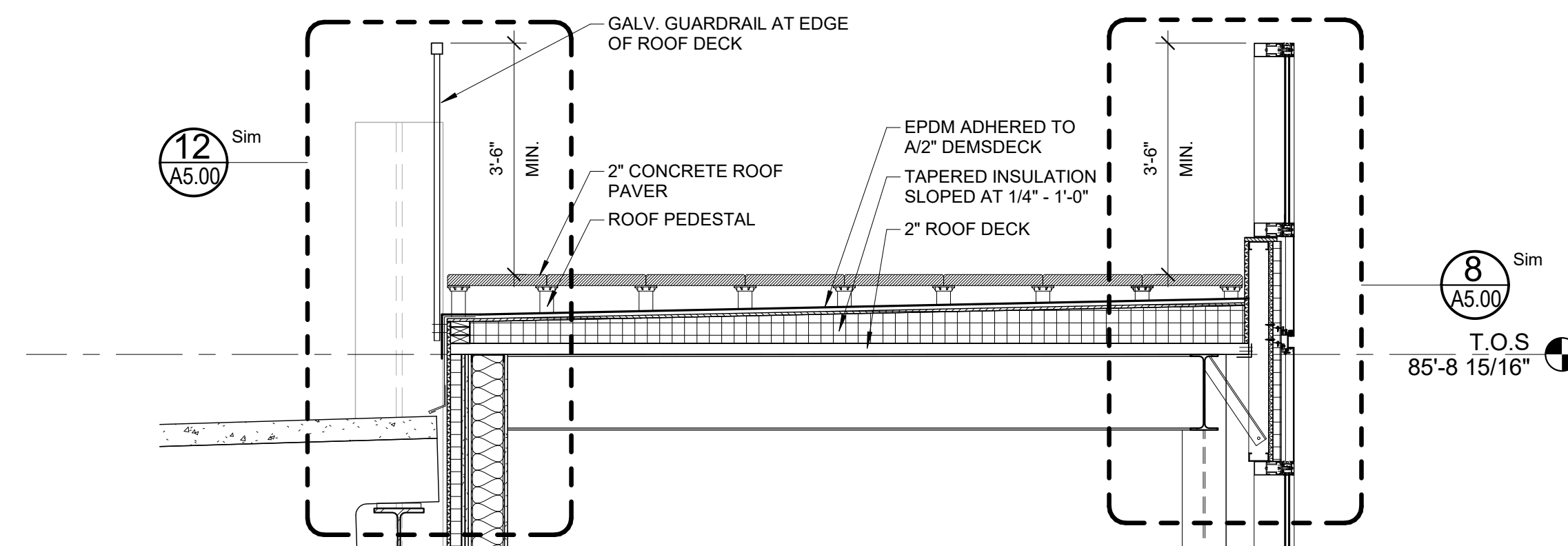

9 EXTERIOR ROOFTOP DECK

1/2" = 1'-0"



Prepared For: Owner	Project: Ocean Gateway Addition	Revisions:
Address: City, State	167 Fore Street Portland, Maine	
Architect: ARCHETYPE Architects 48 Union Wharf Portland, Maine 04101 (207) 772-6022 ARCHETYPE@ARCHETYPEPEA.COM	Date: --/--/----	Scale: As indicated
Details		A5.00