

Reviewed for Code Compliance
Inspections Division
Approved with Conditions

Strengthening a Remarkable City, Building a Community for Life • Date: 01/06/15

Jeff Levine, AICP, Director
Director of Planning and Urban Development

Tammy Munson
Director, Inspections Division

Electronic Signature and Fee Payment Confirmation

Notice: Your electronic signature is considered a legal signature per state law.

By digitally signing the attached document(s), you are signifying your understanding this is a legal document and your electronic signature is considered a **legal signature** per Maine state law. You are also signifying your intent on paying your fees by the opportunities below.

I, the undersigned, intend and acknowledge that no permit application can be reviewed until payment of appropriate permit fees are **paid in full** to the Inspections Office, City of Portland Maine by method noted below:

Within 24-48 hours, once my complete permit application and corresponding paperwork has been electronically delivered, I intend to **call the Inspections Office** at 207-874-8703 and speak to an administrative representative and provide a credit/debit card over the phone.

Within 24-48 hours, once my permit application and corresponding paperwork has been electronically delivered, I intend to **hand deliver** a payment method to the Inspections Office, Room 315, Portland City Hall.

I intend to deliver a payment method through the U.S. Postal Service mail once my permit paperwork has been electronically delivered.

Applicant Signature:

Date:

I have provided digital copies and sent them on:

Date:

NOTE: All electronic paperwork must be delivered to buildinginspections@portlandmaine.gov or by physical means ie; a thumb drive or CD to the office.



Reviewed for Code Compliance
Inspections Division
Approved with Conditions

Date: 01/06/15

Range Guard Wet Chemical Systems Pre-Engineered Fire Suppression System

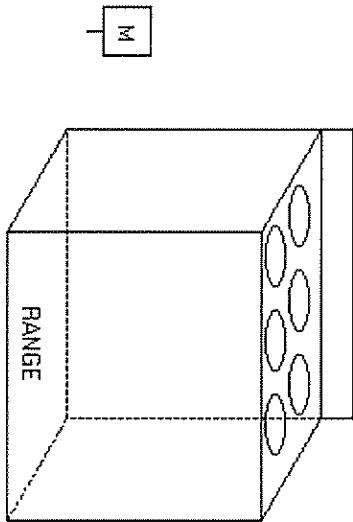
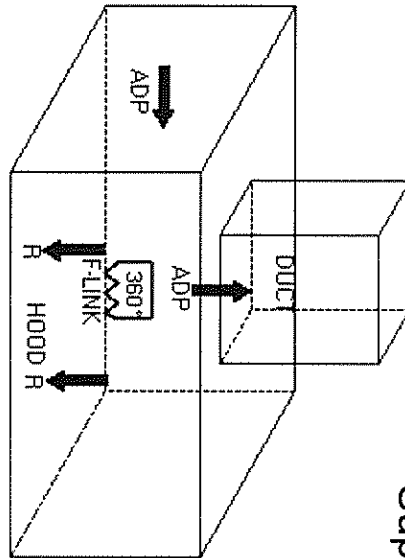
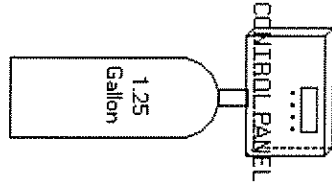

Designed & Installed by:
Firesafe Equipment
PO Box 1355
Auburn, ME 04211
207-784-7525

For:
LOIS NATURAL FOODS

Lic #:

Designer:

Job #:

Date: 12/19/2014

Stamp



Reviewed for Code Compliance
Inspections Division
Approved with Conditions

Fire Suppression System Design Specification

Notes

System Mat

Item Number	Description	
87-120016-001	ADP Nozzle	
WK-282664-000	ML-360 Link 360 F (182 C), ML, Unpaint	1
87-120019-001	R Nozzle	2
60-120071-001	3/4" NPT Mechanical Gas Valve	1
60-120001-001	WHDR-125 Cylinder/Valve, 1.25 Gallon	1
60-120099-001	Universal Control Head Assembly	1
60-120110-001	Remote Manual Release, Combination	1
60-120064-001	Universal Link Detector Housing Kit (A+)	1

Date: 01/06/15



Designed & Installed by:
Firesafe Equipment
PO Box 1355
Auburn, ME 04211
207-784-7525

For:
LOIS NATURAL FOODS



Non-Water-Based Fire Suppression System Peri

If you or the property owner owes real estate or property taxes or user charges on any prop within the city, payment arrangements must be made before permits of any kind are accep



Reviewed for Code Compliance
Inspections Division
Approved with Conditions

Date: 01/06/15

Installation address: 47 India Street CBL: _____

Exact location: (within structure) Lois Natural Foods - Portland, Maine

Type of occupancy(s) (NFPA & ICC): Grocer

Building owner: India Middle Street Junction LLC

Managing Supervisor: Dan Porta License No: N/A

Supervisor phone: 207-653-8707 E-mail: djporta@aol.com

Installing contractor: Firesafe Equipment / Jeff Driscoll License No: N/A

Contractor phone: 207-784-7525 E-mail: dchapman@fire-safe.com

The suppression work to be done will be: New: Renovation: Addition to existing system:

This is an amendment to an existing permit: Yes: NO: Permit no: _____

System Type: Wet Chemical Fire System

NFPA Standard: NFPA 17A Edition: 1996

*Non-NFPA systems are not approved for use within the City of Portland.

Download a new copy of this document from www.portlandmaine.gov/fire for every submittal. Attach all working documents as required on electronic PDF's in **addition** to full sized plans.

COST OF WORK: \$ 2,000.00
PERMIT FEE: \$ 40.00
(\$10 PER \$1,000 + \$30 FOR THE FIRST \$1,000)

Submit all information to the Building Inspections Department, 389 Congress Street, Room 315, Portland, Maine 04101.

Prior to acceptance of any fire protection system, a complete commissioning and acceptance test must be coordinated with all fire system contractors and the Fire Department, and proper documentation of such test(s) provided.

All installation(s) must comply with NFPA and the Fire Department Technical Standard(s).

Applicant signature: *[Signature]* Date: Dec 29, 14