

- NOTES:**
- G.C. SHALL BE RESPONSIBLE FOR VERIFYING ALL DIMENSIONS. G.C. MAY CONTACT ARCHITECT IF DIMENSIONAL CLARIFICATION IS NEEDED DUE TO SCALE OF DRAWINGS.
 - PROTECT STEEL WITH INTUMESCENT PAINT PER ARCHITECT. PROTECT ALL STEEL NOT REQUIRING INTUMESCENT PAINT (PER ARCHITECT) WITH PRIMER. DO NOT PAINT TOP FLANGES OF BEAMS.
 - TOP OF CONCRETE DECK IS AT 100'-0" BENEATH BUILDINGS. TOP OF CONCRETE VARIES WITH SLOPE TO DRAINS IN COURTYARD. TOP OF STEEL SHALL BE 9'-1 1/4", UNLESS NOTED OTHERWISE AS (E0) IN INCHES. BEAMS WITH (M) SHALL BE LOCATED AT ELEVATION AS REQUIRED TO BE FLUSH WITH ITS SUPPORTING BEAMS (MATCH THE TOP FLANGE ELEVATIONS).
 - SEE SHEETS S.N.O AND S.N.I FOR ADDITIONAL STRUCTURAL NOTES.
 - HOLES FOR DRAINS MAY BE CORED AFTER CONCRETE DECK IS COMPLETED. CONTRACTOR SHALL ENSURE THAT CORING DOES NOT CUT STEEL BEAMS. CONTRACTOR IS RESPONSIBLE FOR LOCATING DRAINS.
 - SAW-CUT CONTROL JOINTS ARE NOT REQUIRED IN THE SECOND FLOOR CONCRETE DECK. RANDOM CRACKING WILL OCCUR. SLAB WILL BE COVERED BY UNIT FLOOR FRAMING OR COURTYARD ASSEMBLY.
 - COORDINATE FLOOR OPENINGS WITH MECHANICAL DRAWINGS. G.C. TO ENSURE OPENINGS ARE LOCATED IN SUCH A MANNER AS NOT TO INTERFERE WITH THE BEAM FLANGE.
 - VERIFY STAIR OPENING DIMENSIONS WITH ARCHITECTURAL DRAWINGS.
 - PROVIDE WEB STIFFENERS AT ALL LOCATIONS AS SHOWN ON DETAILS 1/S1.4 AND 6/S1.5.
 - COMPOSITE STEEL BEAMS SHALL HAVE SHEAR STUDS WELDED TO THEIR TOP FLANGES. THE NUMBER OF STUDS REQUIRED IN THE LENGTH OF THE BEAM ARE INDICATED AS (#), EXCEPT WHERE NON-COMPOSITE BEAMS REQUIRE ZERO STUDS AND ARE NOTED (NC).
 - FASTEN COMPOSITE DECKING TO STEEL WITH 5/8" PUDDLE WELDS IN A 24/4 PATTERN. PROVIDE WELDED OR SCREENED SIDE LAP FASTENERS AT A MAXIMUM SPACING OF 36" ON CENTER.
 - ALL STEEL CONNECTIONS MUST BE DESIGNED AND SUBMITTED BY FABRICATOR'S ENGINEER. FOR REACTIONS SHOWN AND PER DESIGN REACTION TABLE. BEAMS MUST FRAME OVER COLUMNS WHEN REACTIONS ARE GREATER THAN SHEAR TAB CAPACITIES AND WHERE INDICATED ON THIS PLAN.

SECOND FLOOR FRAMING PLAN - BUILDING 1
Scale: 1/8" = 1'

MINIMUM DESIGN REACTION SCHEDULE (FOR BEAM REACTIONS NOT SHOWN ON PLANS OR DETAILS)

BEAM	SHEAR TAB TO COLUMN	DOUBLE ANGLE TO BEAM
W8, W10	8 KIPS	37 KIPS
W12, W14	16 KIPS	55 KIPS
W16	26 KIPS	74 KIPS
W18	36 KIPS	92 KIPS
W21	46 KIPS	111 KIPS
W24	56 KIPS	130 KIPS
W27	66 KIPS	148 KIPS
W30	75 KIPS	167 KIPS
W33	85 KIPS	186 KIPS
W36	95 KIPS	186 KIPS

NOTE: REFER TO PLANS FOR BEAM END REACTIONS. SEE ABOVE SCHEDULE FOR REACTIONS NOT NOTED ON PLANS. ALL OTHER MEMBERS SHALL BE DESIGNED FOR AN 6 KIP MINIMUM REACTION. FABRICATOR SHALL PROVIDE SHOP DRAWINGS INDICATING THE PROVIDED CAPACITY OF ALL TYPICAL CONNECTIONS.

NOTE: EDGE OF CONCRETE DECK SHALL BE LOCATED FLUSH TO OUTSIDE FACE OF FOUNDATION AND HELD BACK 1/2" FROM OUTSIDE FACE OF STUDS (ABOVE AND BELOW) AT PERIMETER SUPPORTED BY STEEL BEAMS AND AT INTERIOR OPENINGS IN CONCRETE DECK (U.N.O.)

NOTE: TYPICAL LIGHT GAGE FRAMING BELOW SECOND FLOOR FRAMING IS NON-LOAD BEARING PARTITION WALLS DESIGNED BY OTHERS WITH DEFLECTION TRACKS AT TOP OF WALLS - SEE SHEET S.N.O FOR LIGHT GAGE NOTES.

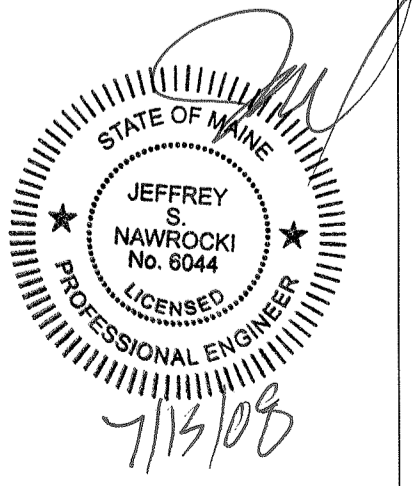

NOTE: EDGE OF CONCRETE DECK SHALL BE LOCATED FLUSH TO OUTSIDE FACE OF FOUNDATION AND HELD BACK 1/2" FROM OUTSIDE FACE OF STUDS (ABOVE AND BELOW) AT PERIMETER SUPPORTED BY STEEL BEAMS AND AT INTERIOR OPENINGS IN CONCRETE DECK (U.N.O.)

NOTE: SEE SHEET S1.0 FOR CONNECTION SCHEDULE AND SECOND FLOOR FRAMING NOTES

NOTE: TYPICAL LIGHT GAGE FRAMING BELOW SECOND FLOOR FRAMING IS NON-LOAD BEARING PARTITION WALLS DESIGNED BY OTHERS WITH DEFLECTION TRACKS AT TOP OF WALLS - SEE SHEET S1.0 FOR LIGHT GAGE NOTES.

NOTE: PROVIDE SMOOTH SLAB FINISH OF CONCRETE DECK BENEATH BUILDING LOCATIONS AND LIGHT BROOM FINISH AT ALL AREAS TO RECEIVE TOPPING AT COURTYARD

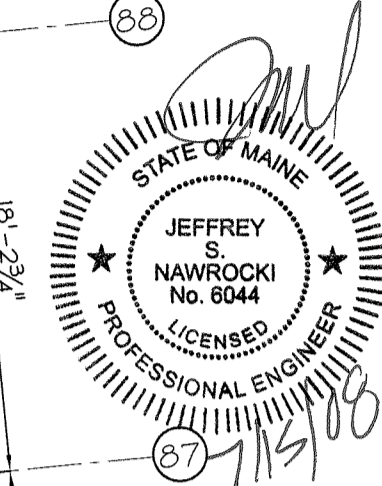

JON
Associates, Inc.
Consulting Structural Engineers
One Adams Street
Portsmouth, NH 03801
(603) 433-3839
Fax: (603) 431-2811
www.joneng.com

DAVID M. WHITE, ARCHITECT
403 Tbetts Hill Road
P. O. Box 447
Goffstown, New Hampshire 03045
(603) 497-3405

THE VILLAGE AT OCEAN GATE, LLC
GFI Partners
93 Pearl Street
Boston, MA 02110

THE BAY HOUSE
Middle Street
Portland, Maine

GARAGE DECK FRAMING
Phase 1 / Building 2
Scale: 1/8" = 1' 0"
Commission No: 06-008
Date: July 15, 2008

REVISIONS:

DRG. NO.
S1.1

SECOND FLOOR FRAMING PLAN
1 - BUILDING 2
S1.1 Scale: 1/8" = 1'

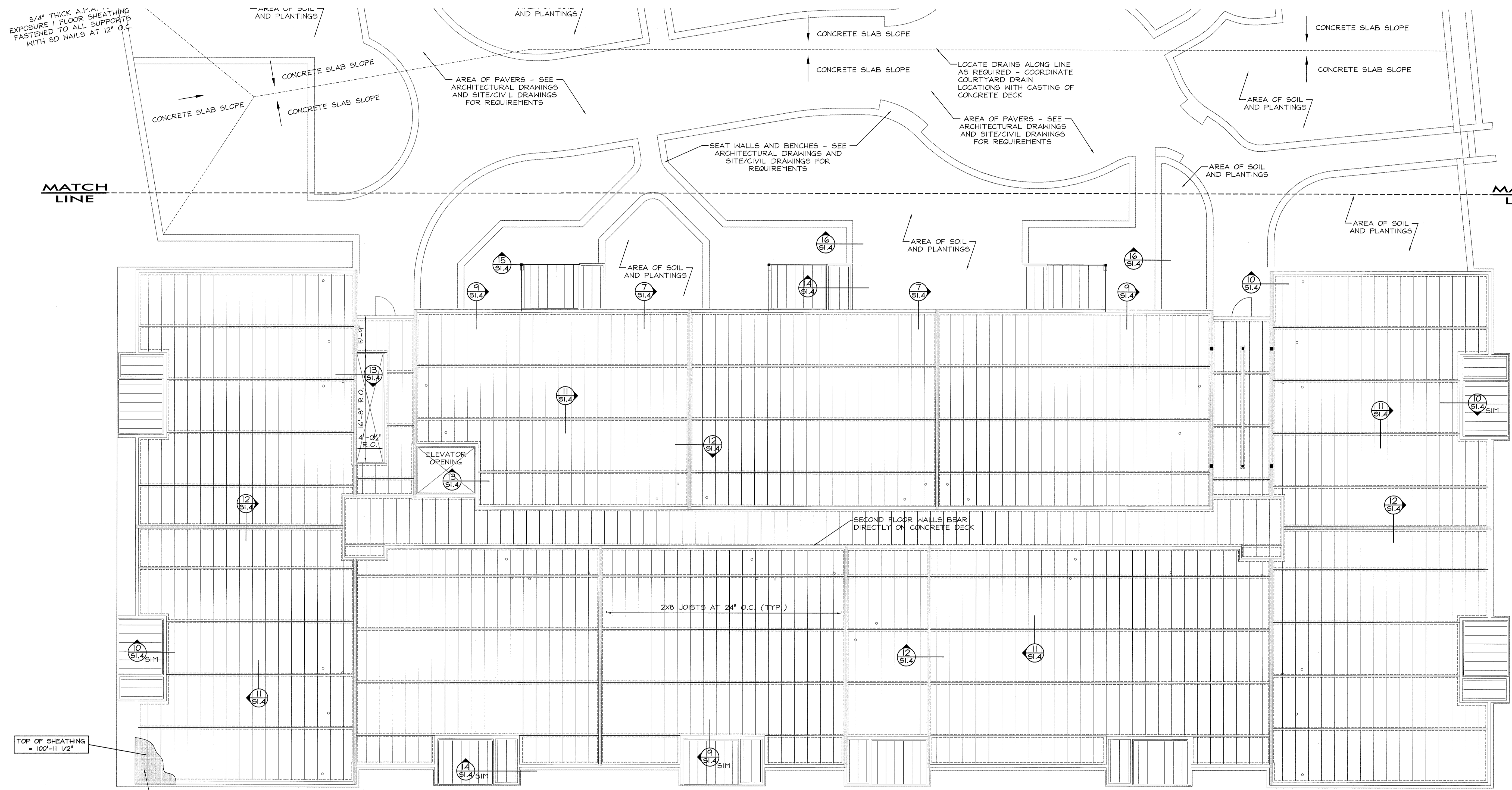

3/4" THICK A.P.A. RATED EXPOSURE I FLOOR SHEATHING FASTENED TO ALL SUPPORTS WITH 8D NAILS AT 12" O.C.

MATCH LINE

MATCH LINE

TOP OF SHEATHING = 100'-11 1/2"

3/4" THICK A.P.A. RATED EXPOSURE I FLOOR SHEATHING FASTENED TO ALL SUPPORTS WITH 8D NAILS AT 12" O.C.

NOTE: FRAMER SHALL COORDINATE LOCATIONS OF BEARING PLATES AND RIMBOARDS AS REQUIRED TO MINIMIZE JOIST CUTS REQUIRED (USE STANDARD LUMBER LENGTHS - JOISTS MUST NOT SPAN MORE THAN 8' TO ENSURE DISTRIBUTION OF LOAD ON CONCRETE DECK)

SECOND FLOOR OVERBUILD FRAMING PLAN - BUILDING 1
 Scale: 1/8" = 1'



NOTE: FRAMER SHALL COORDINATE LOCATIONS OF BEARING PLATES AND RIMBOARDS AS REQUIRED TO MINIMIZE JOIST CUTS REQUIRED (USE STANDARD LUMBER LENGTHS - JOISTS MUST NOT SPAN MORE THAN 8' TO ENSURE DISTRIBUTION OF LOAD ON CONCRETE DECK)



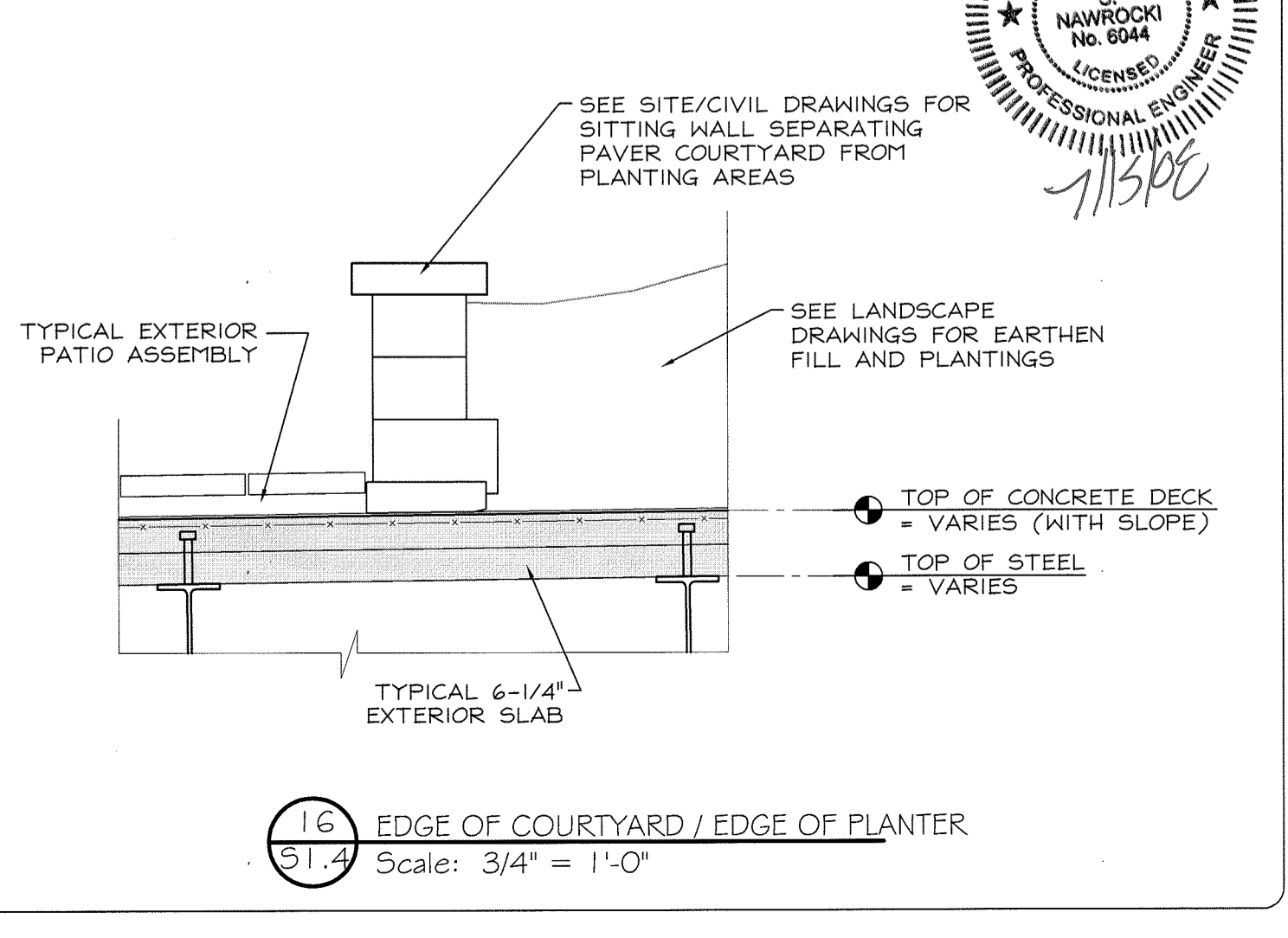
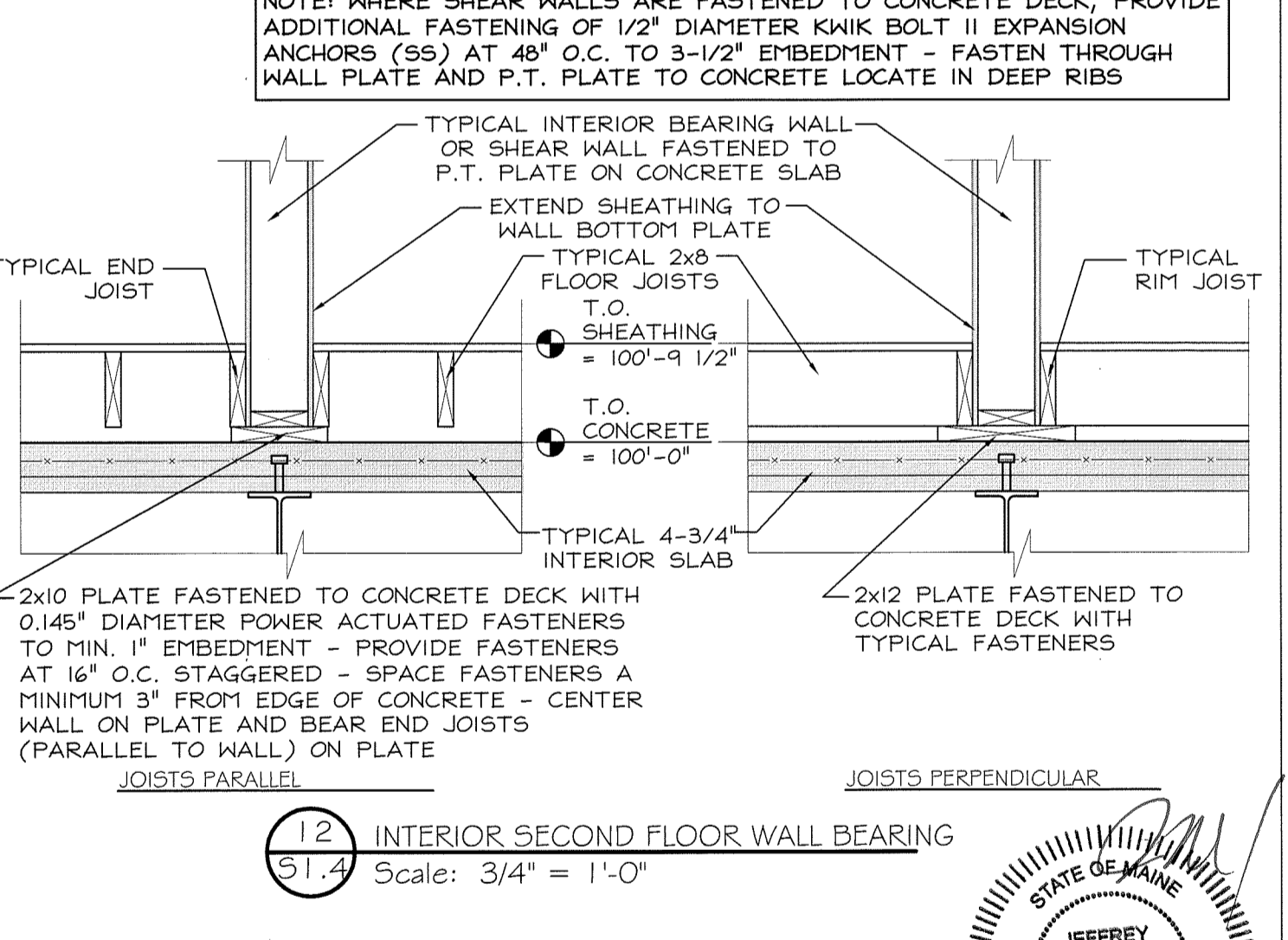
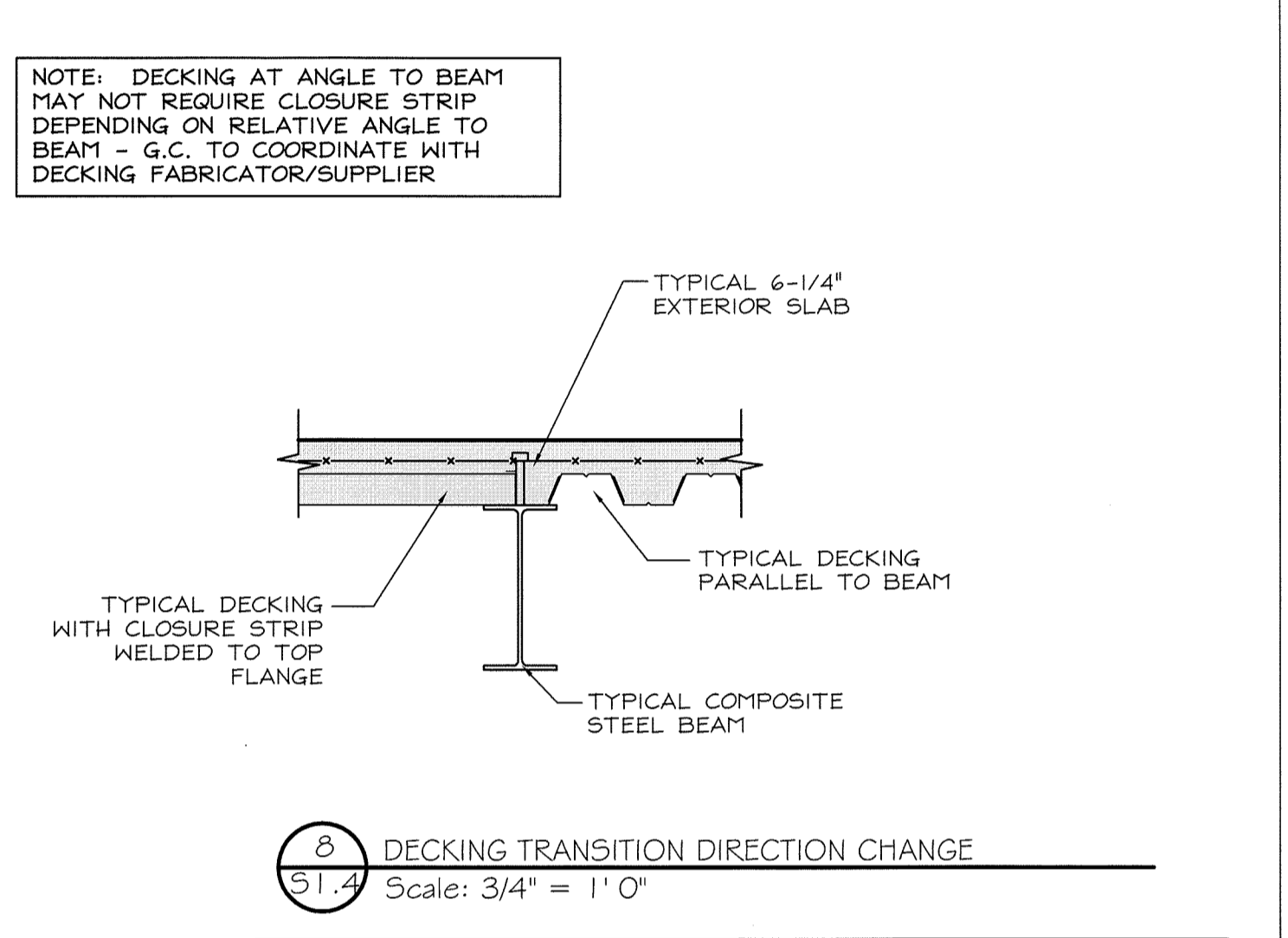
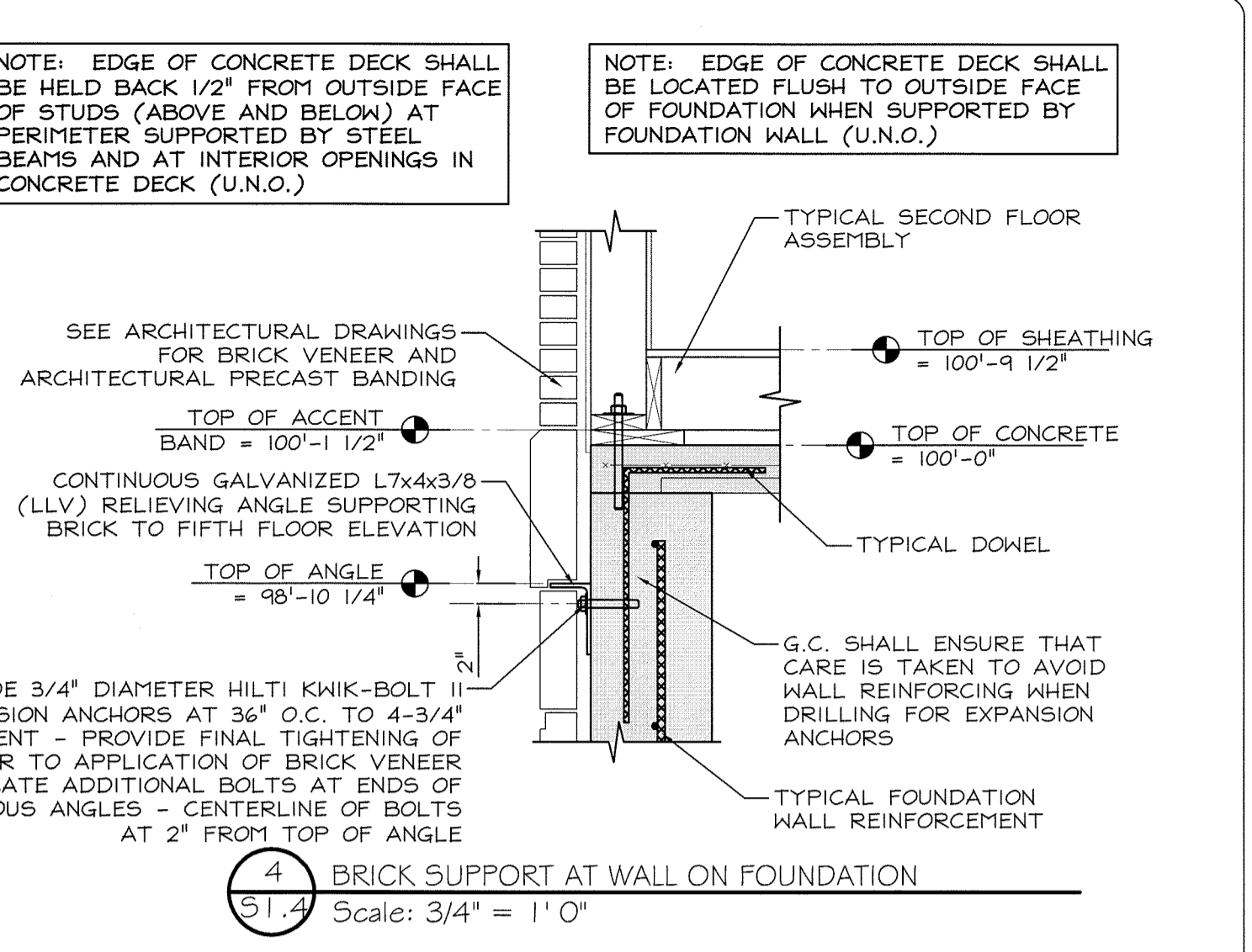
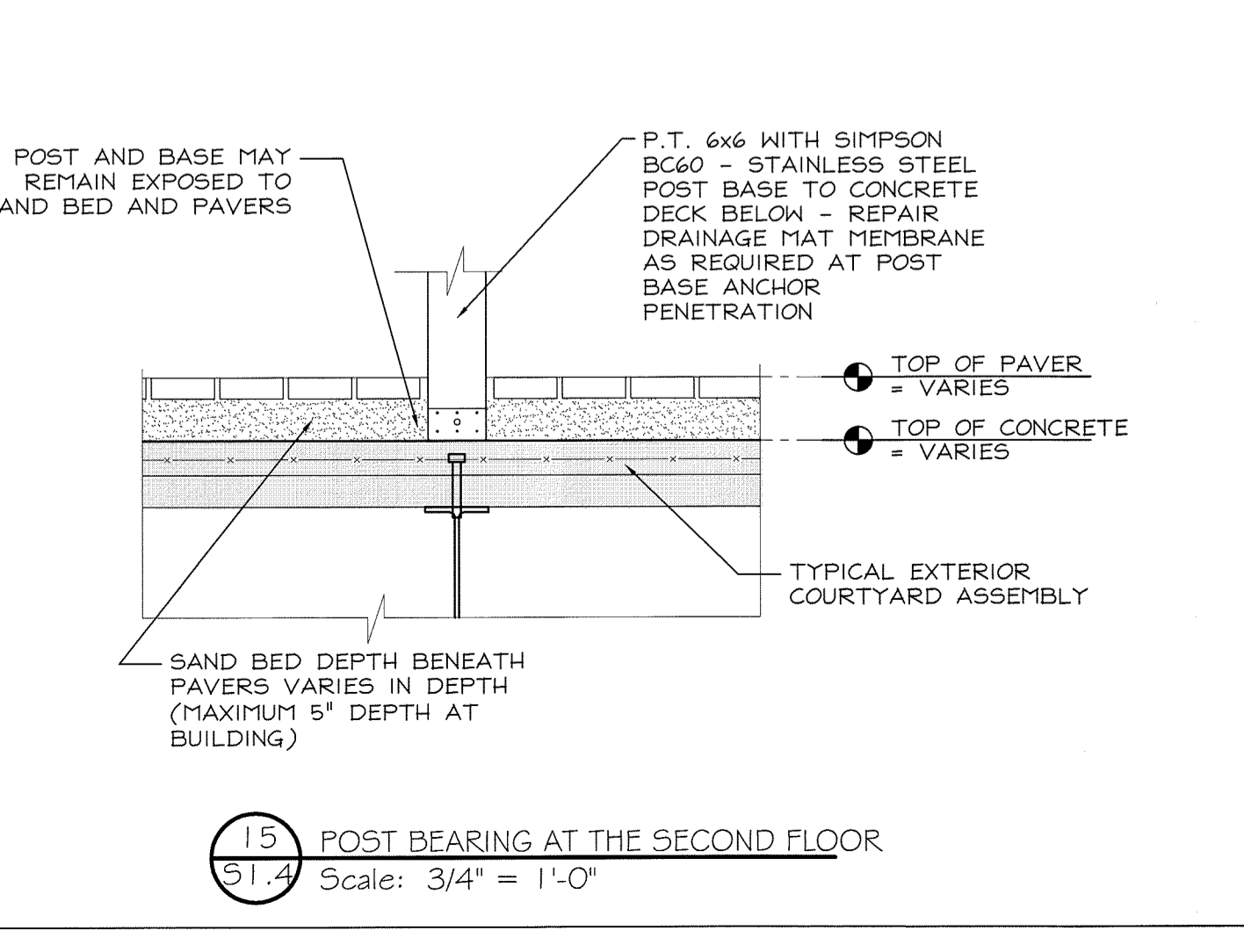
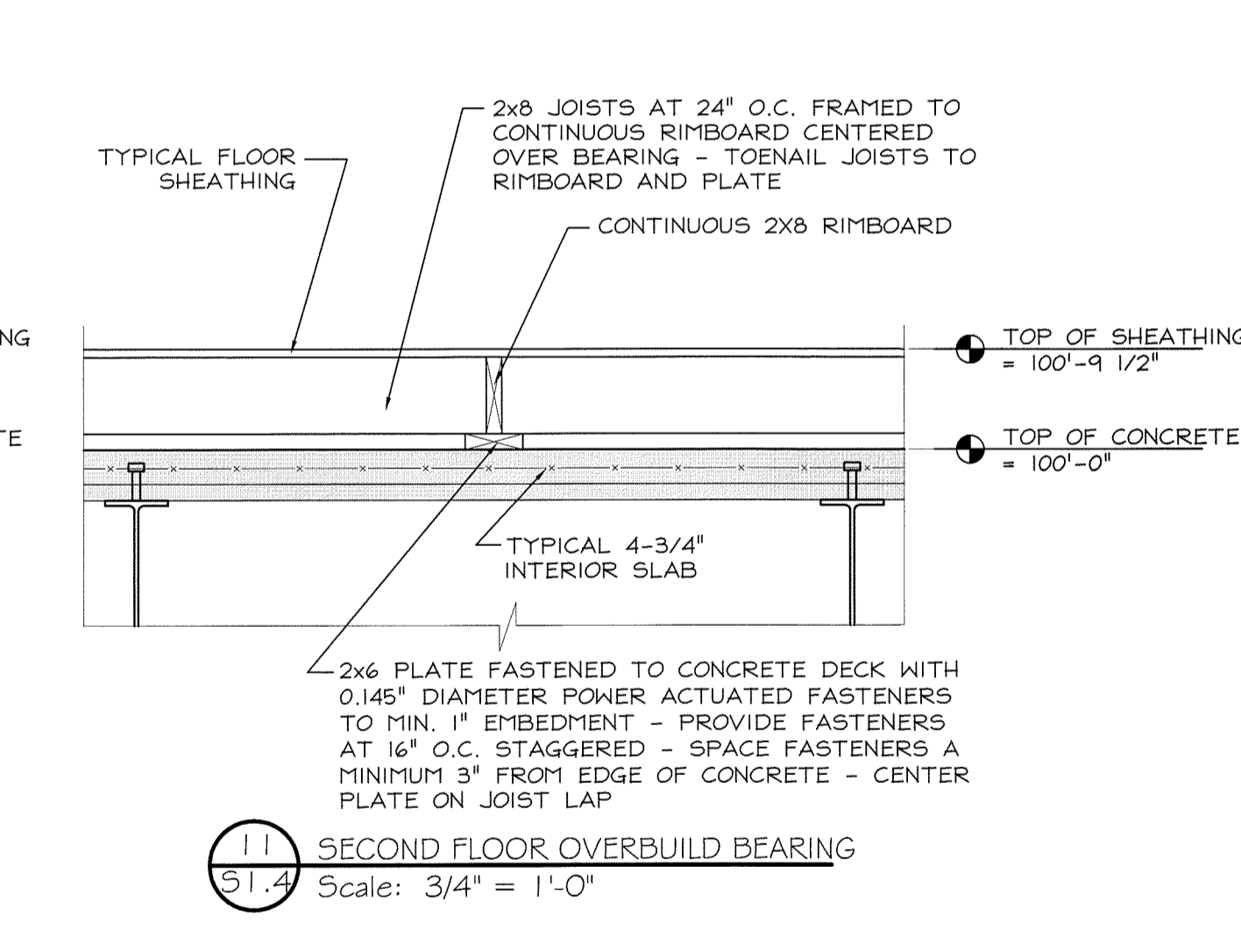
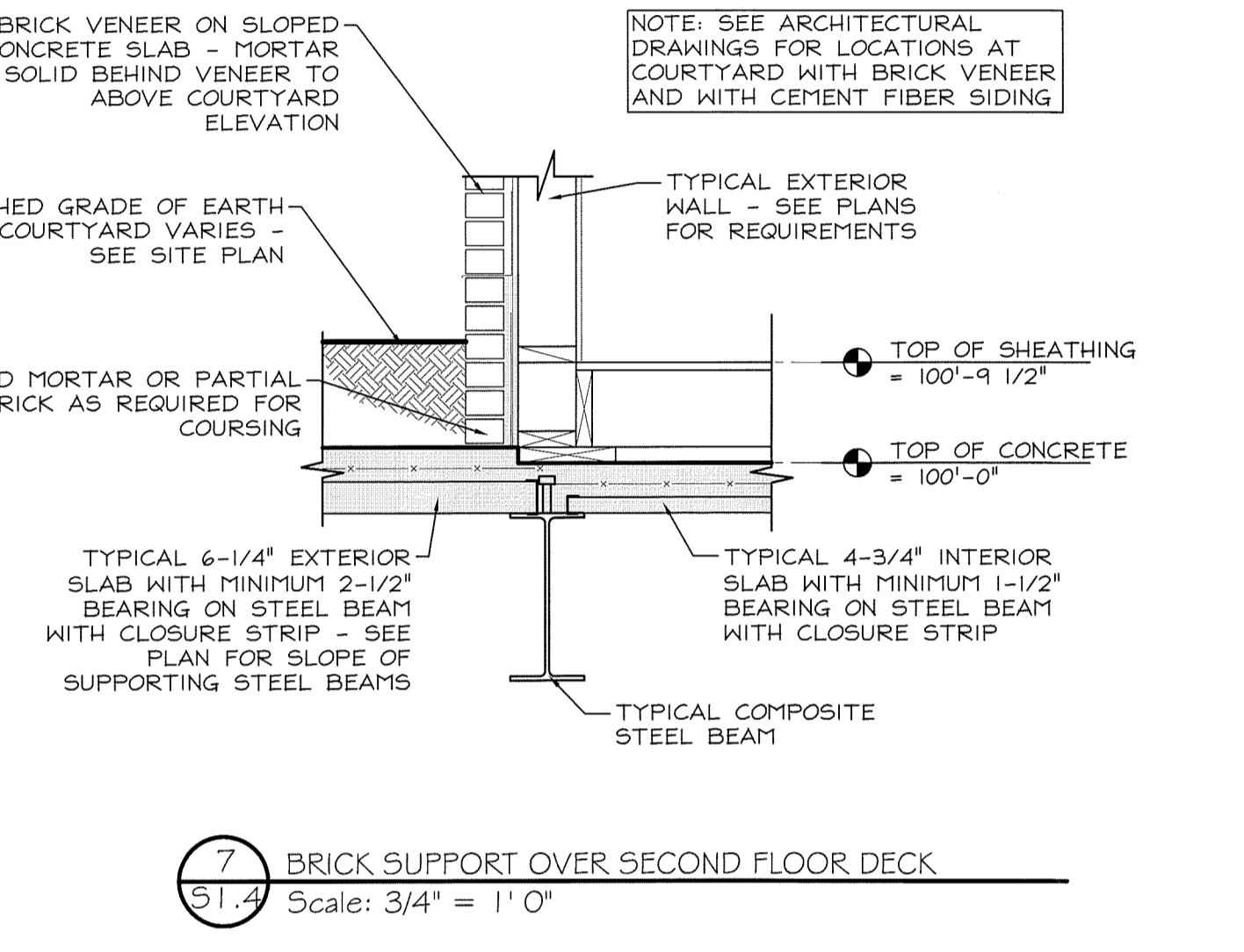
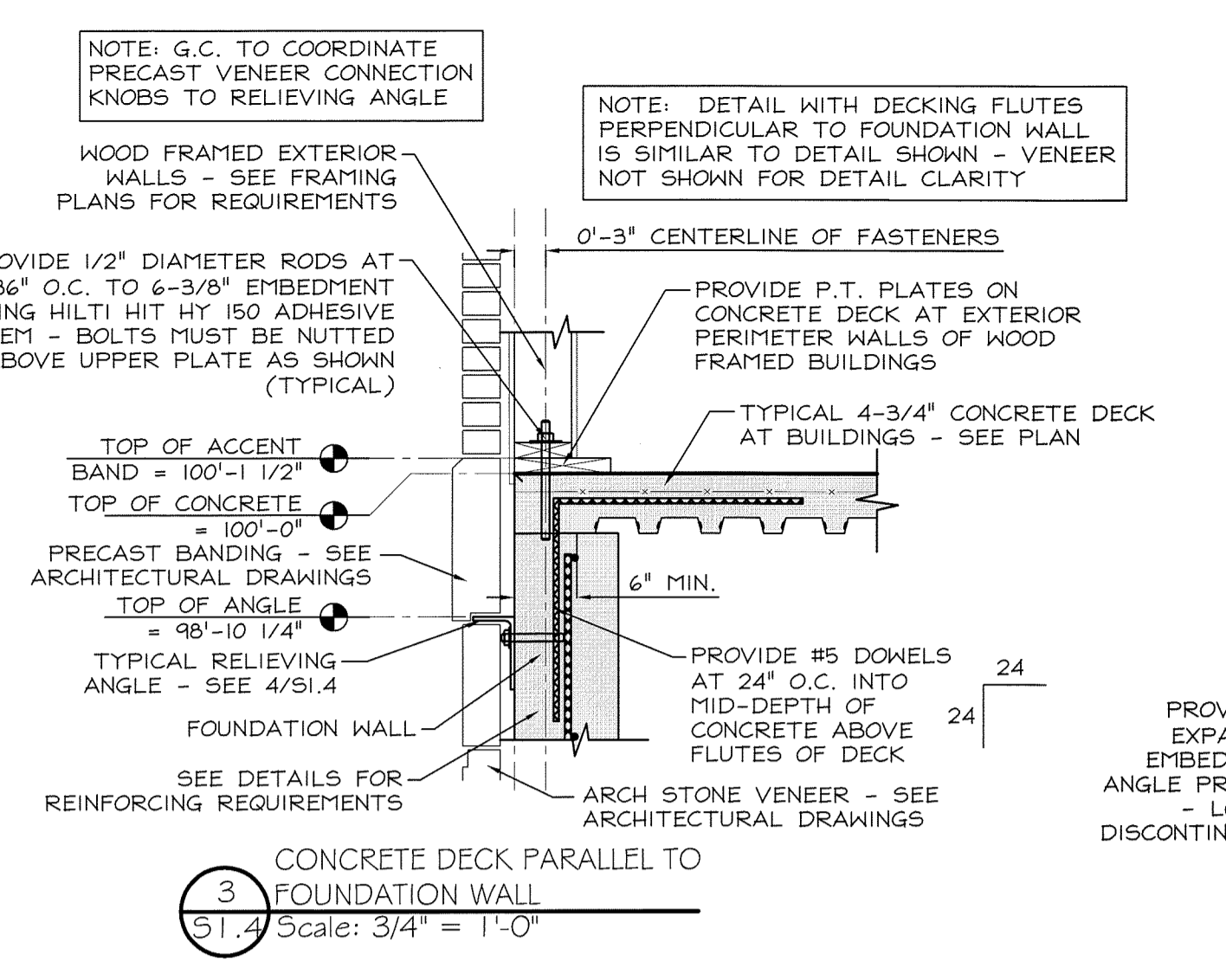
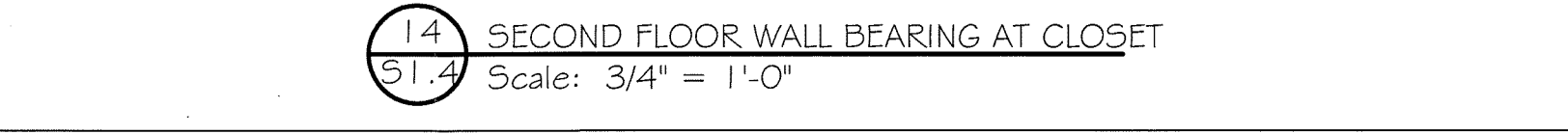
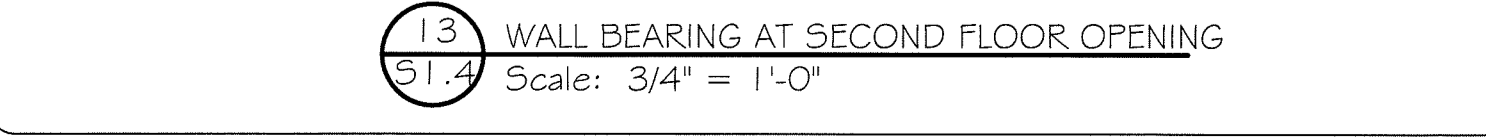
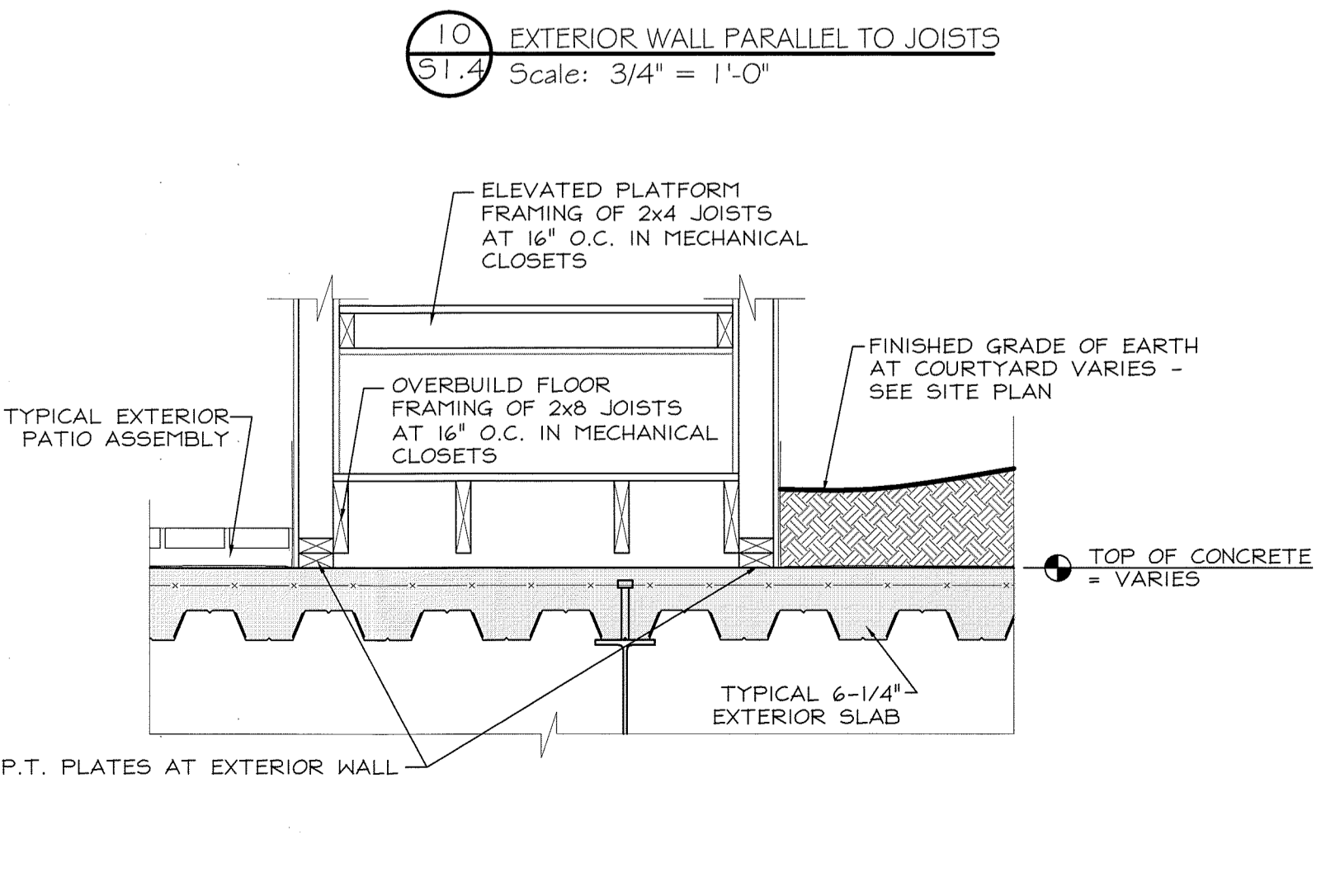
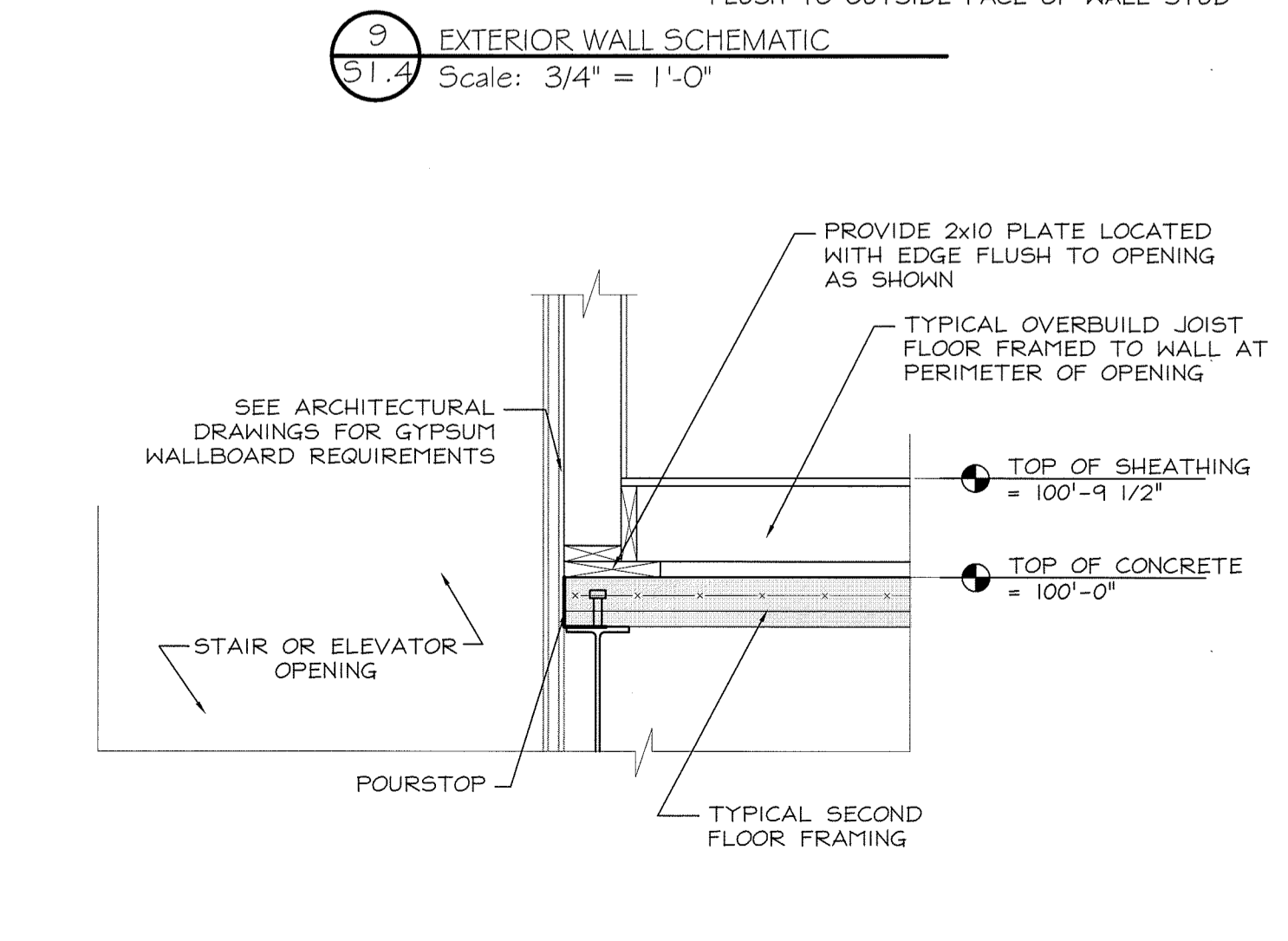
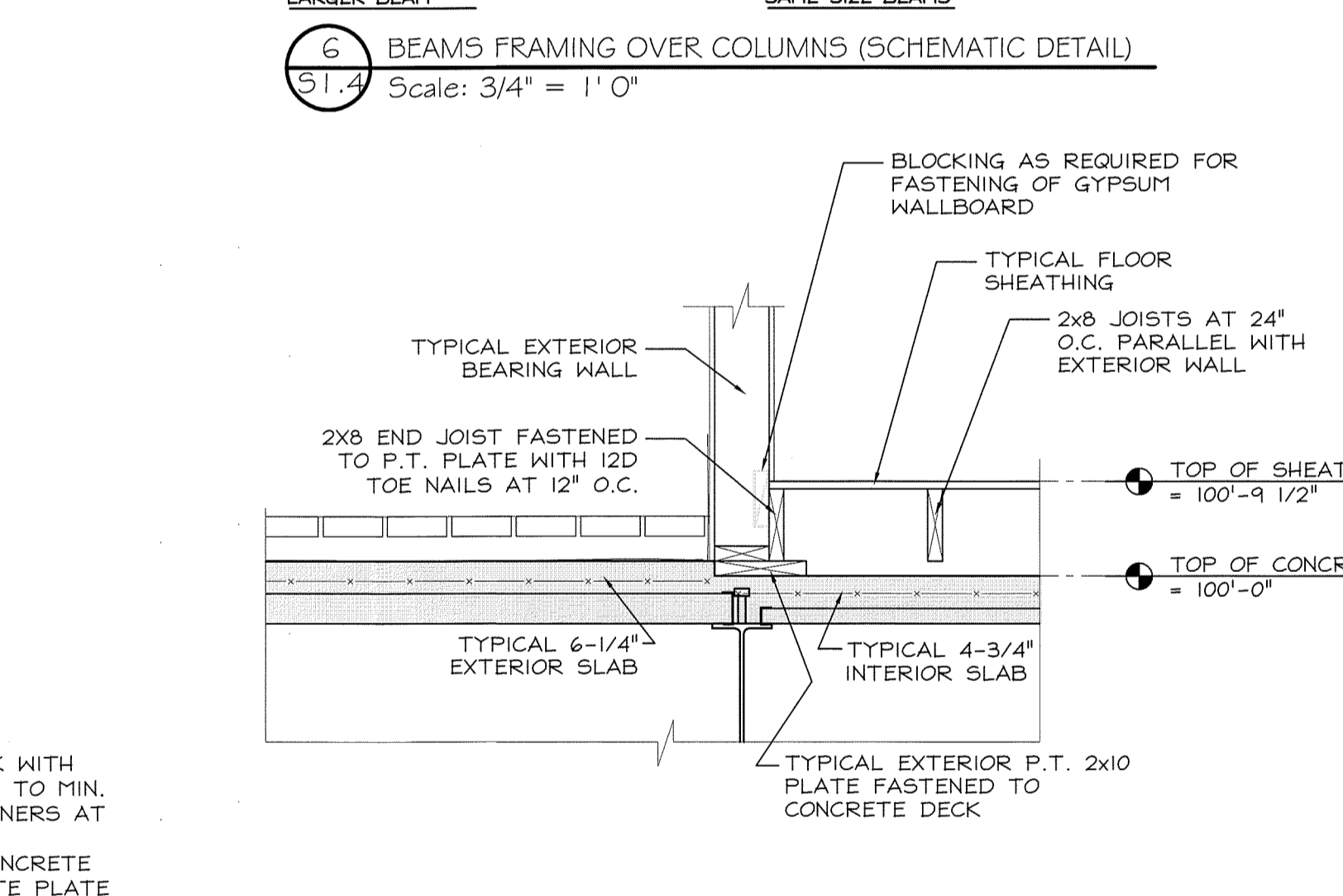
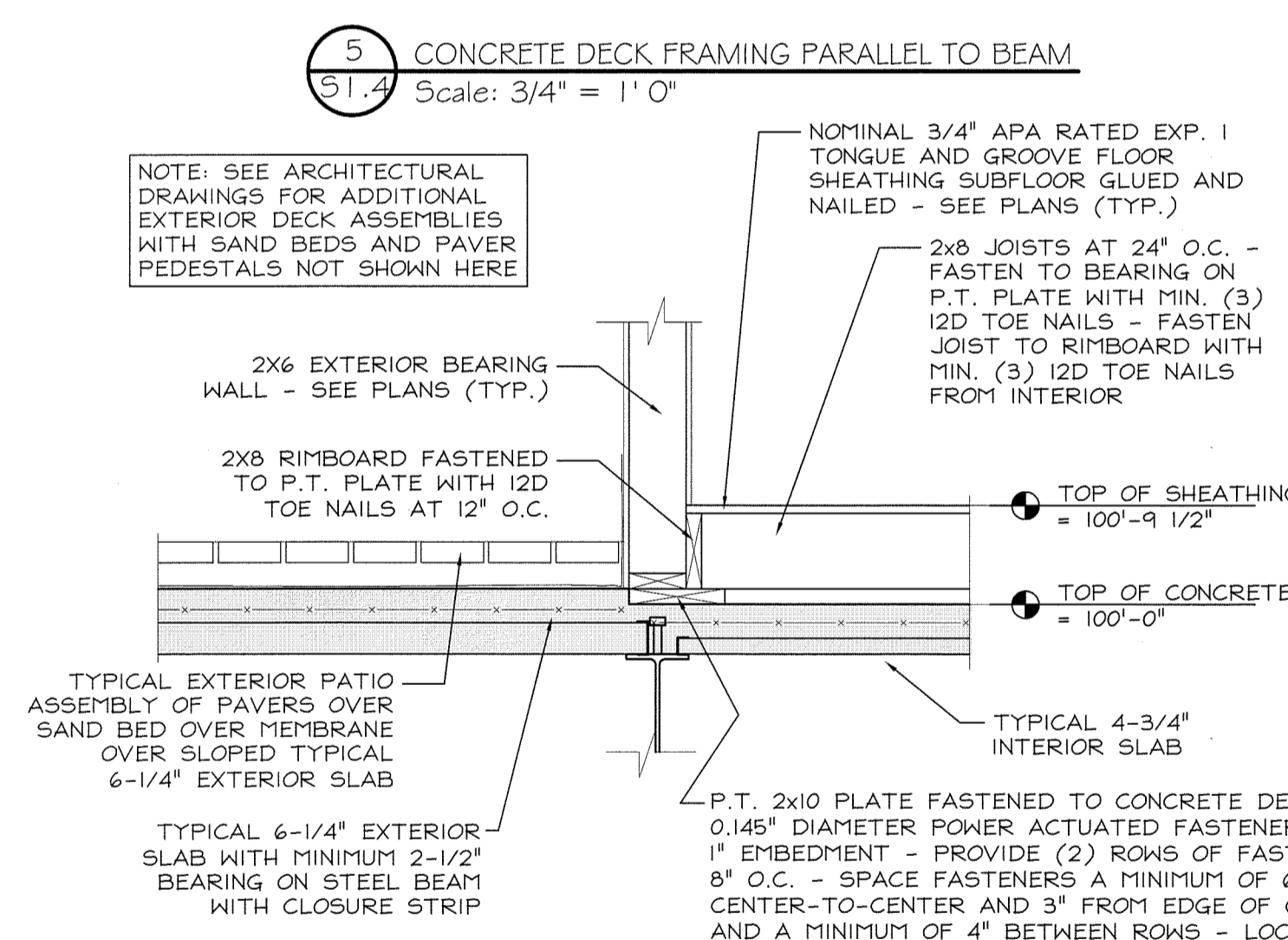
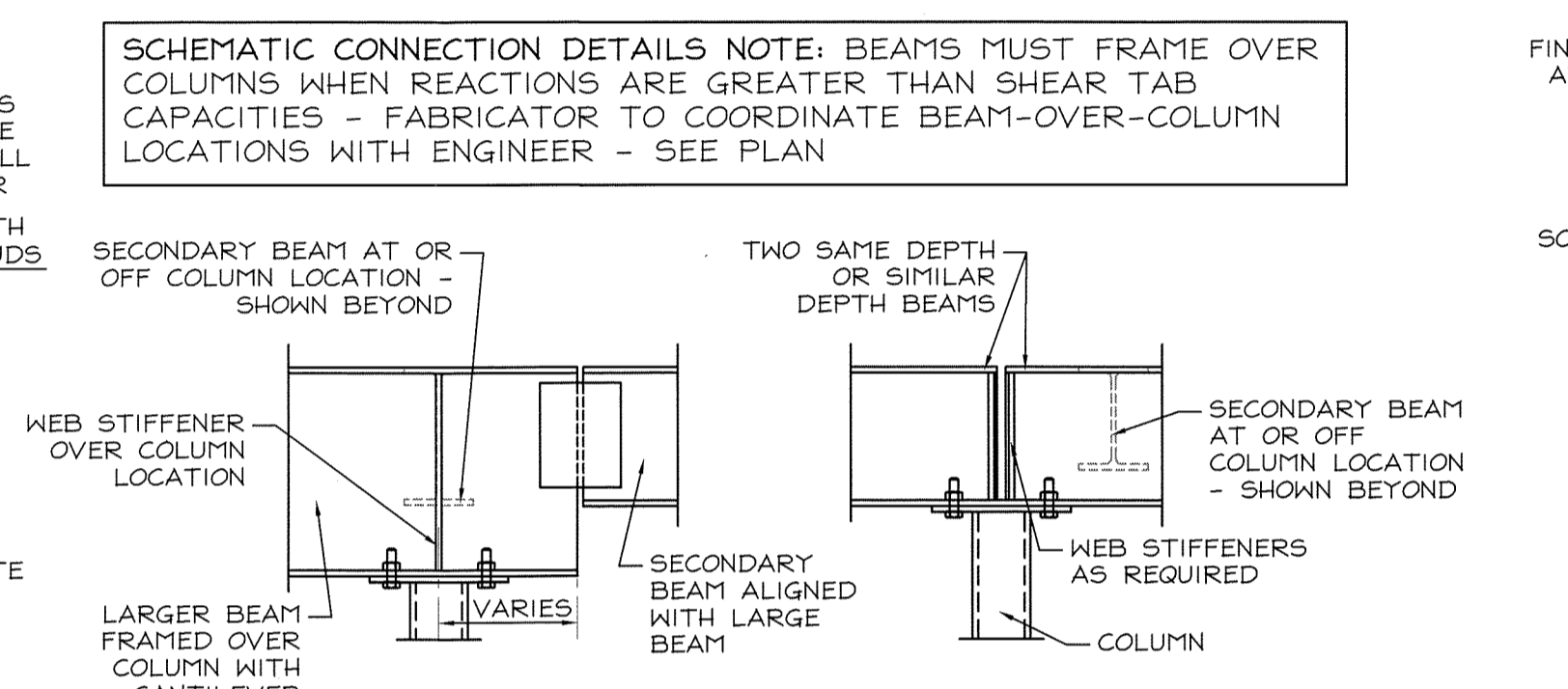
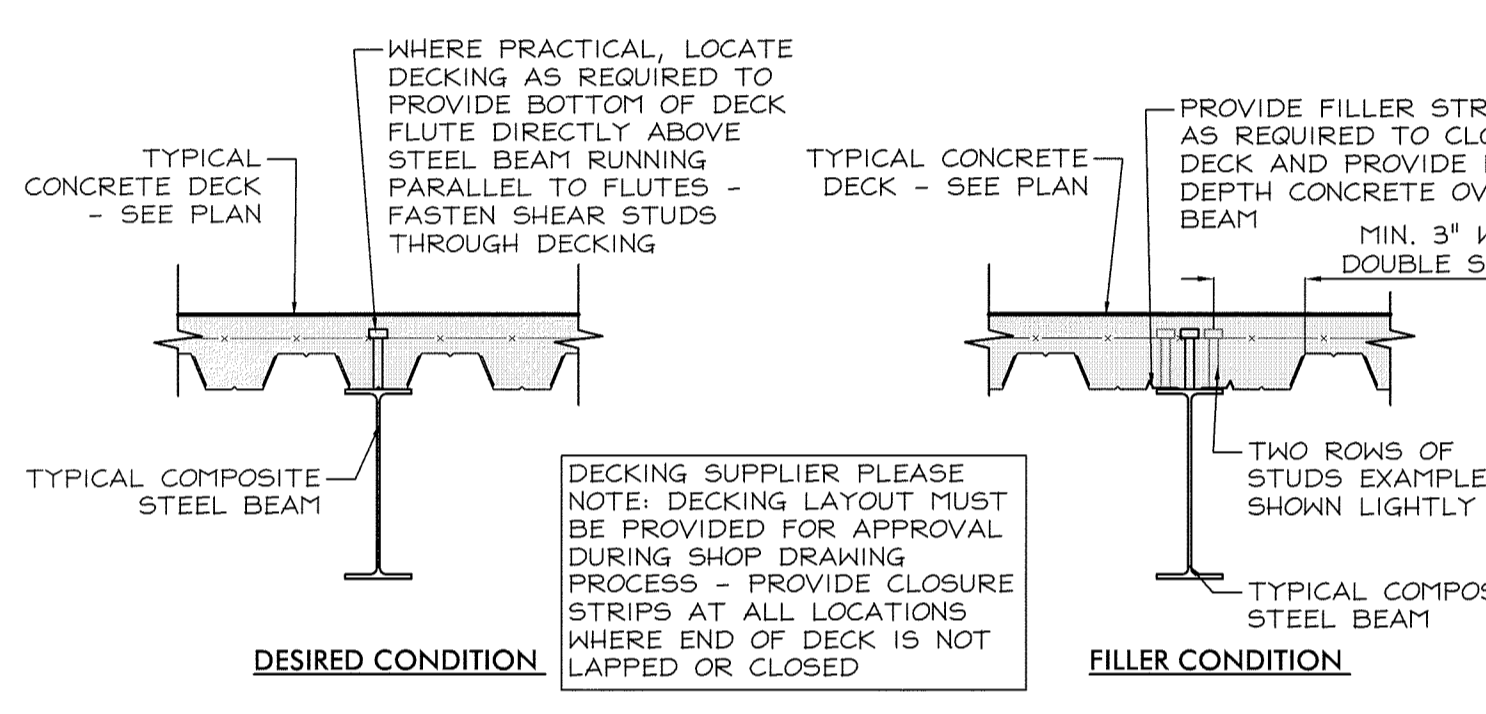
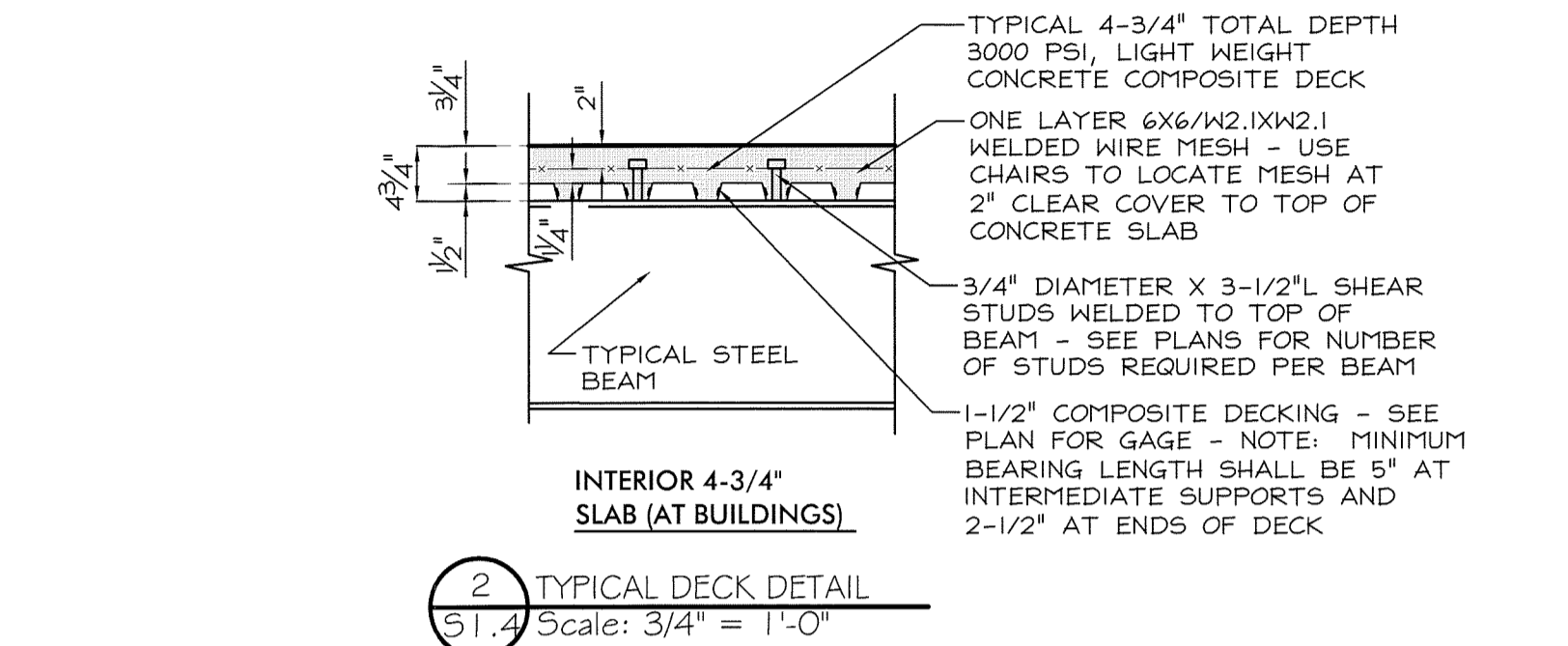
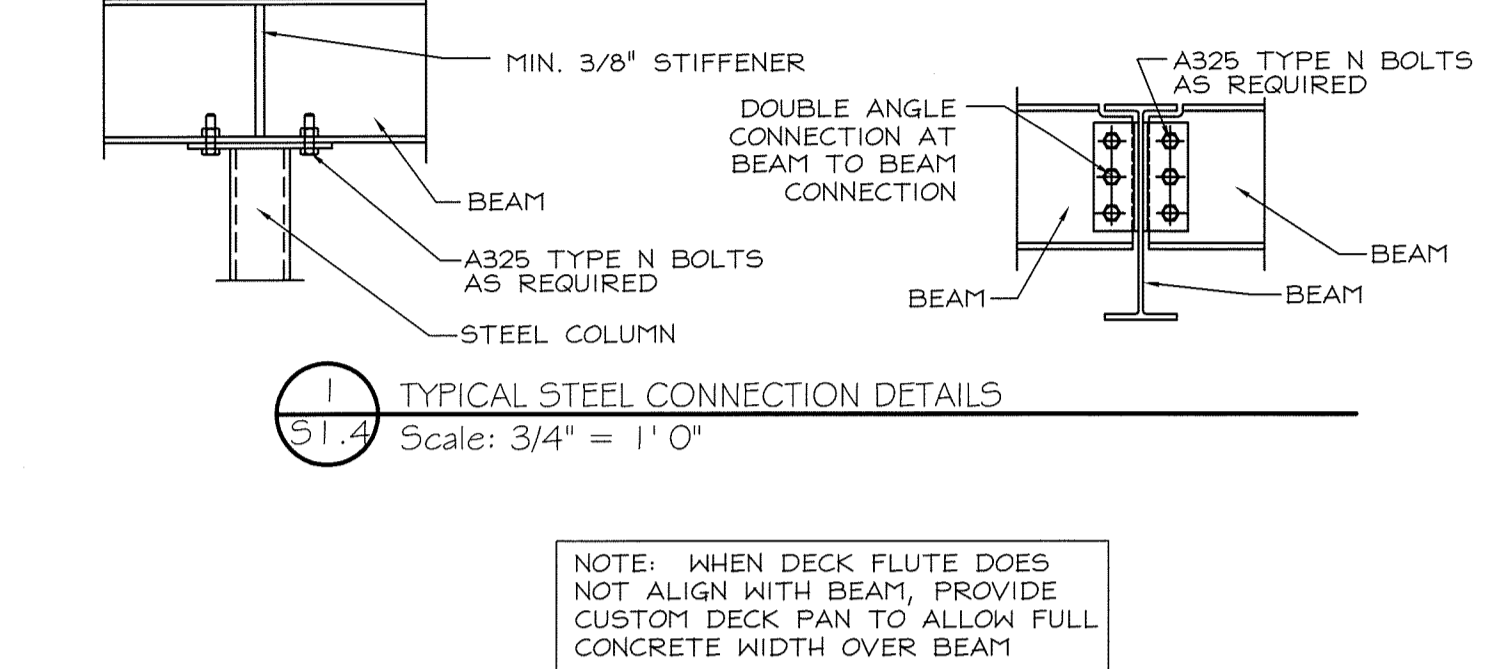
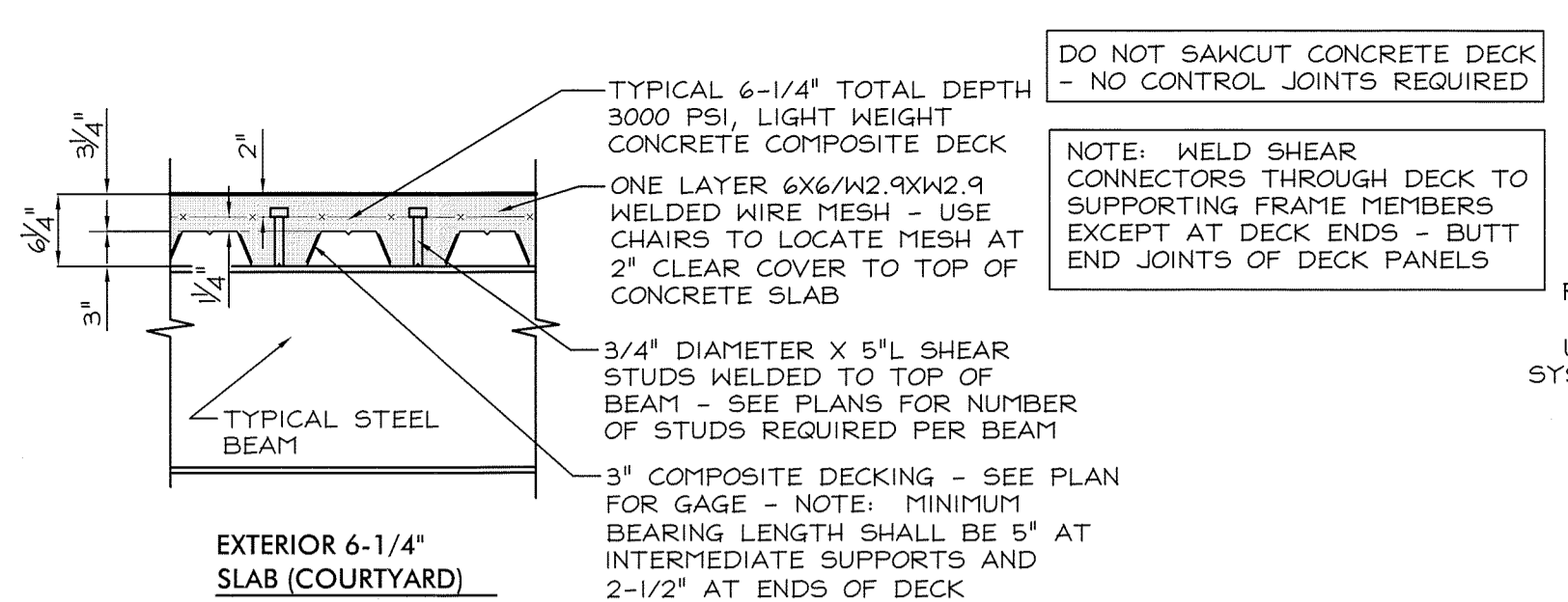
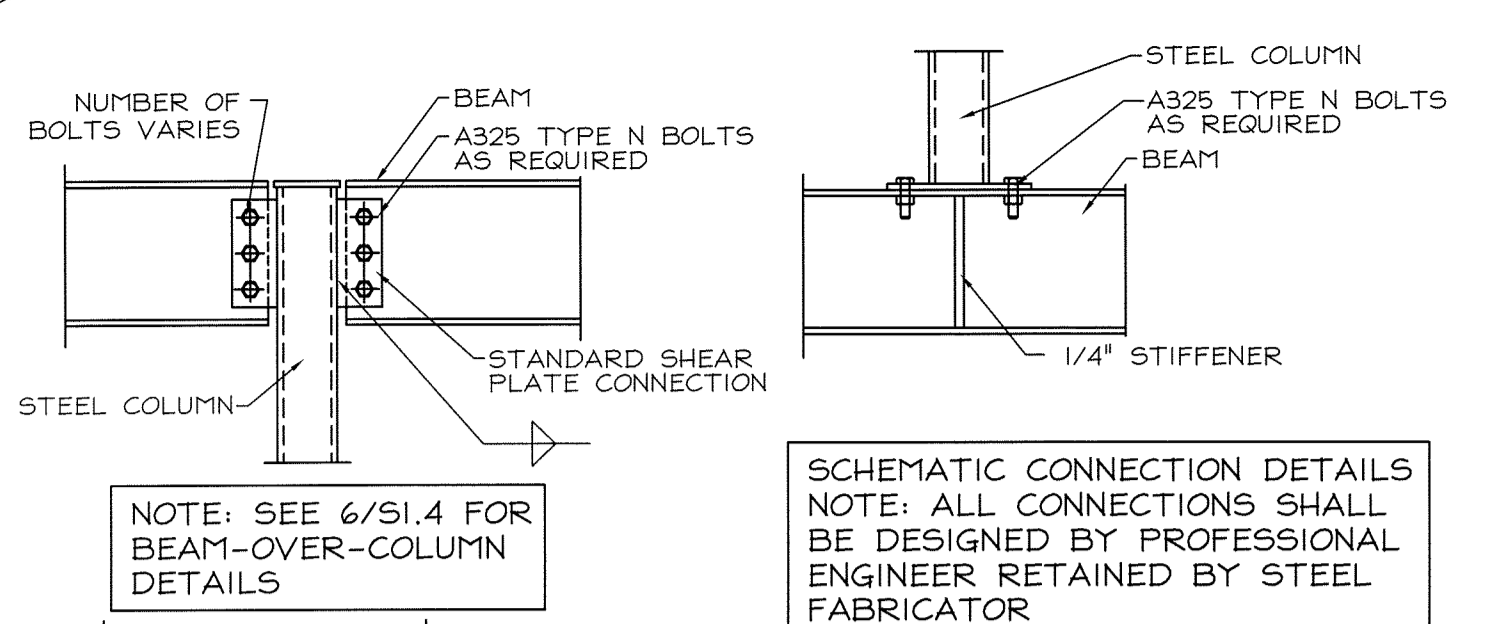

STATE OF MAINE
 JEFFREY NAWROCKI
 No. 6044
 LICENSED PROFESSIONAL ENGINEER
 11/5/06