

SECTION 1
3/4"=1'-0" S1.5

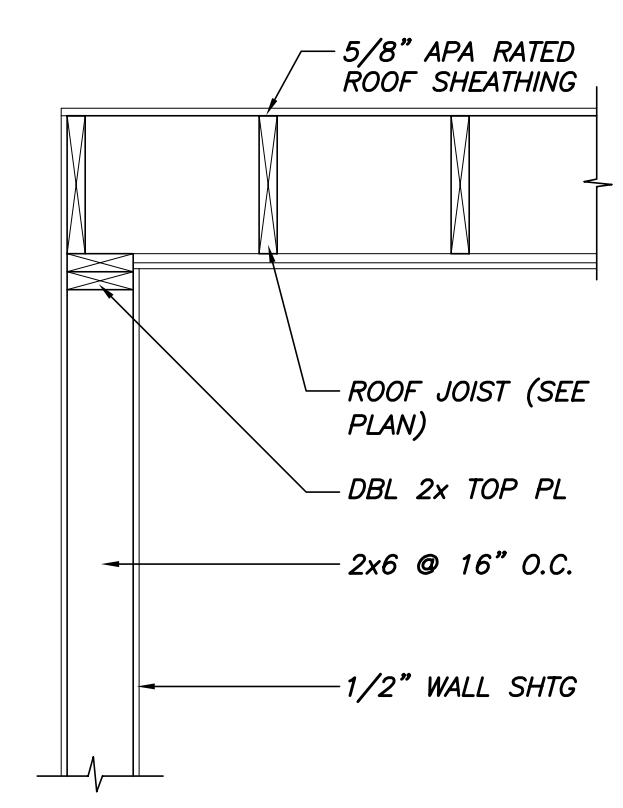

SECTION 2
3/4"=1'-0" S1.5

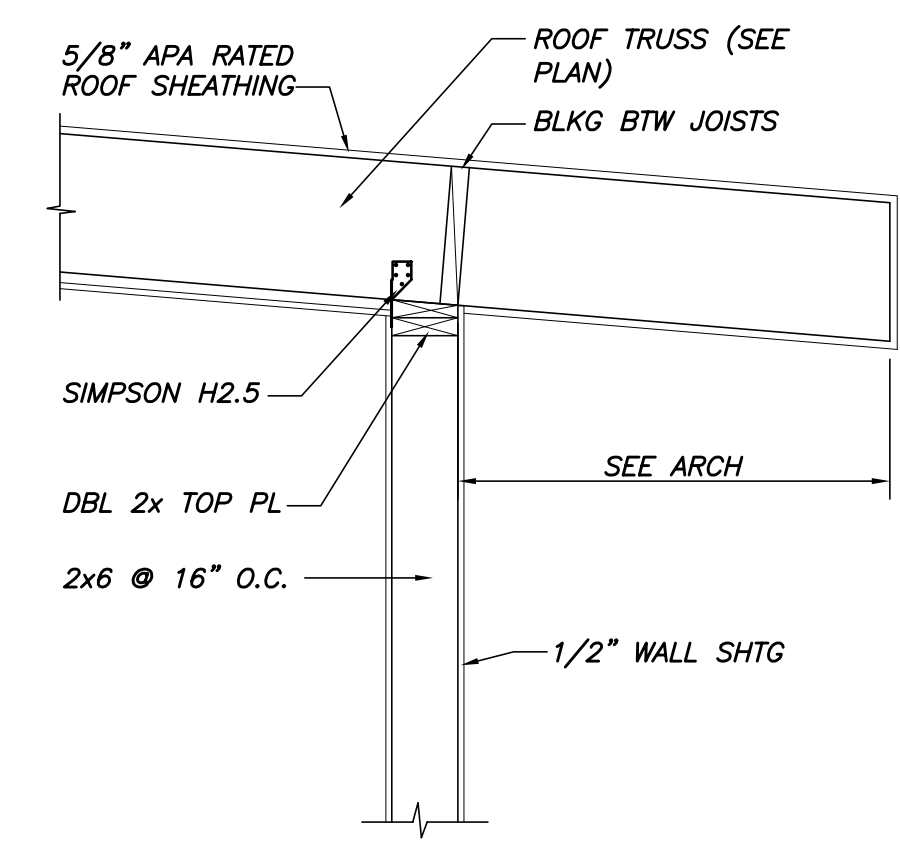

SECTION 3
3/4"=1'-0" S1.5

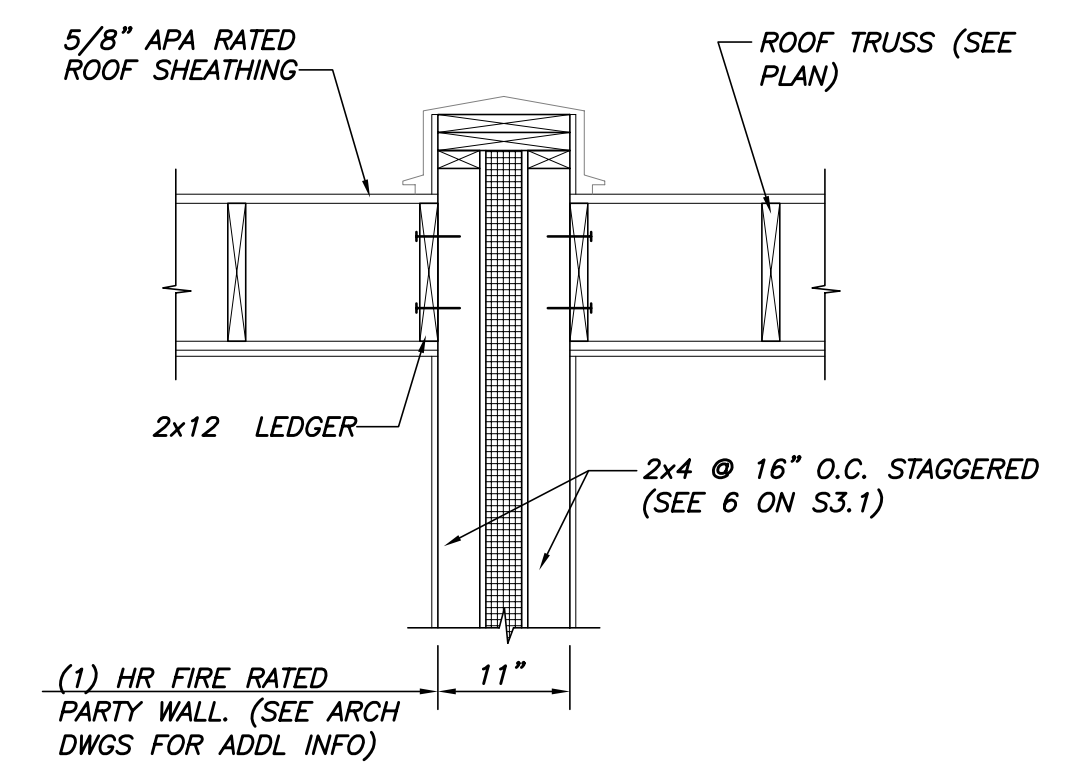

SECTION 4
3/4"=1'-0" S1.5

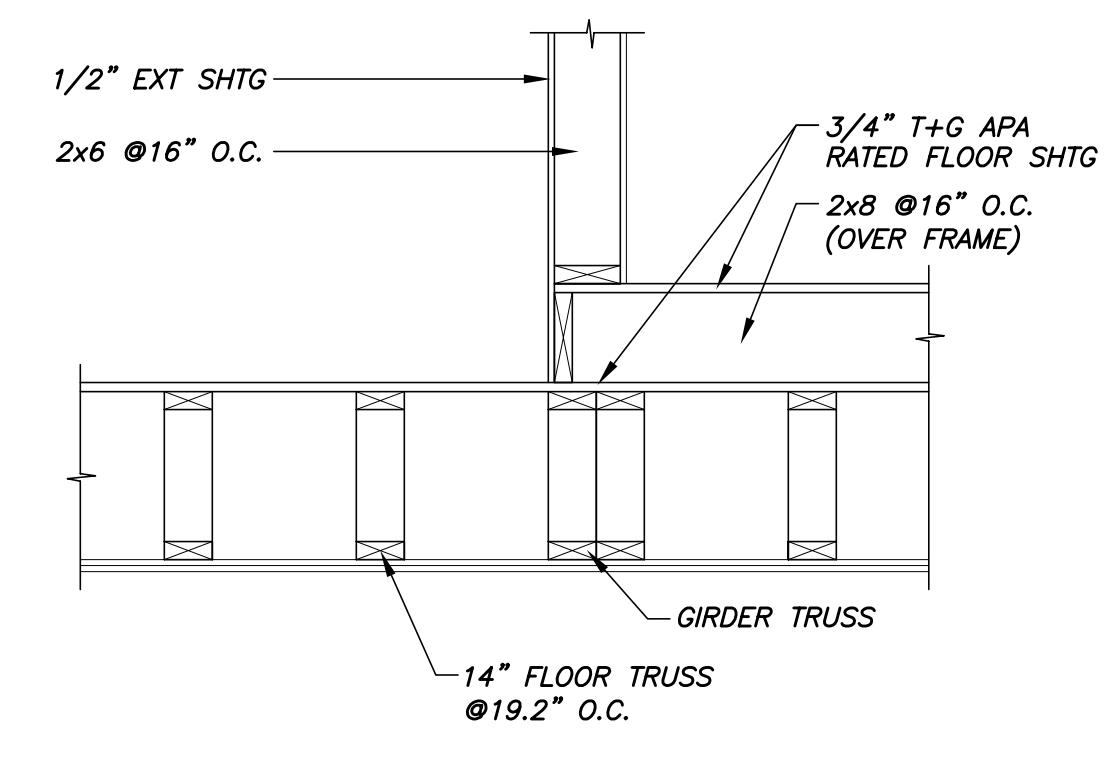

SECTION 5
3/4"=1'-0" S1.4

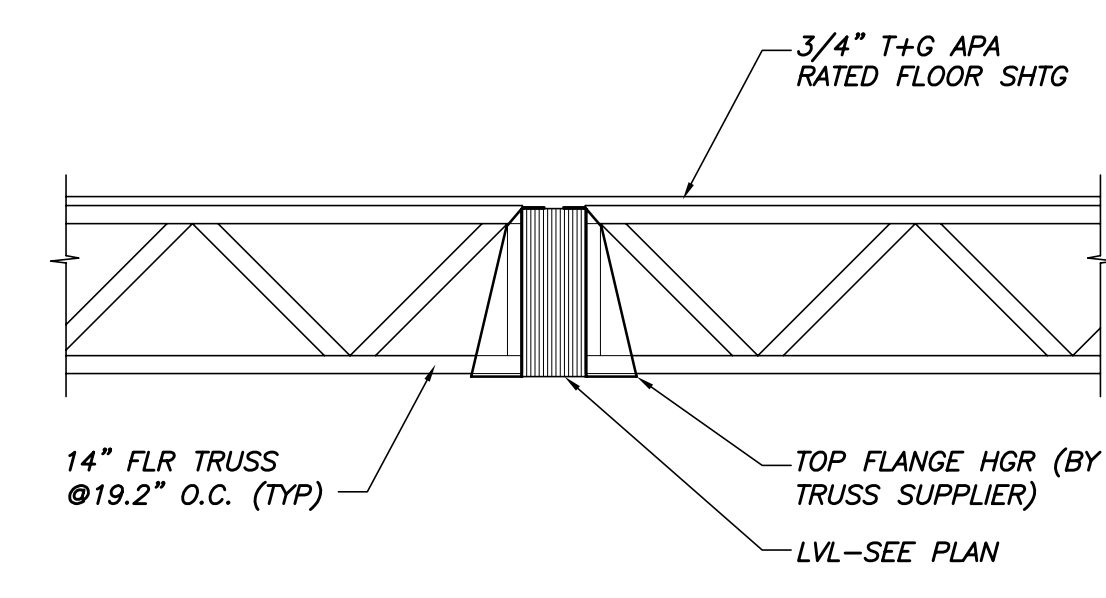

SECTION 6
3/4"=1'-0" S1.4

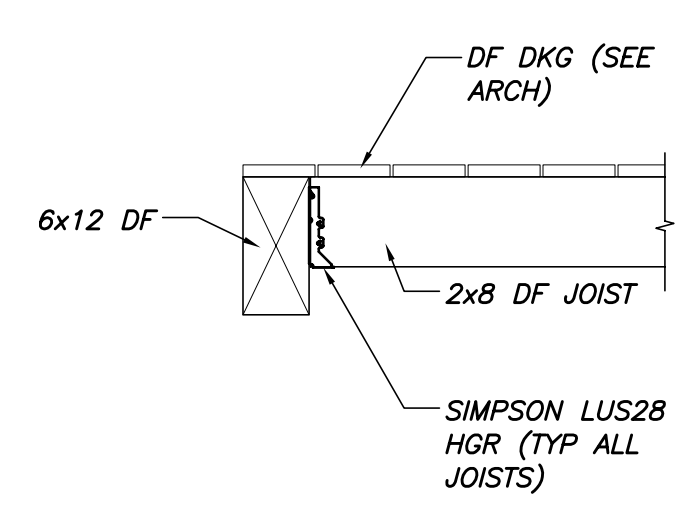

SECTION 7
3/4"=1'-0" S1.4

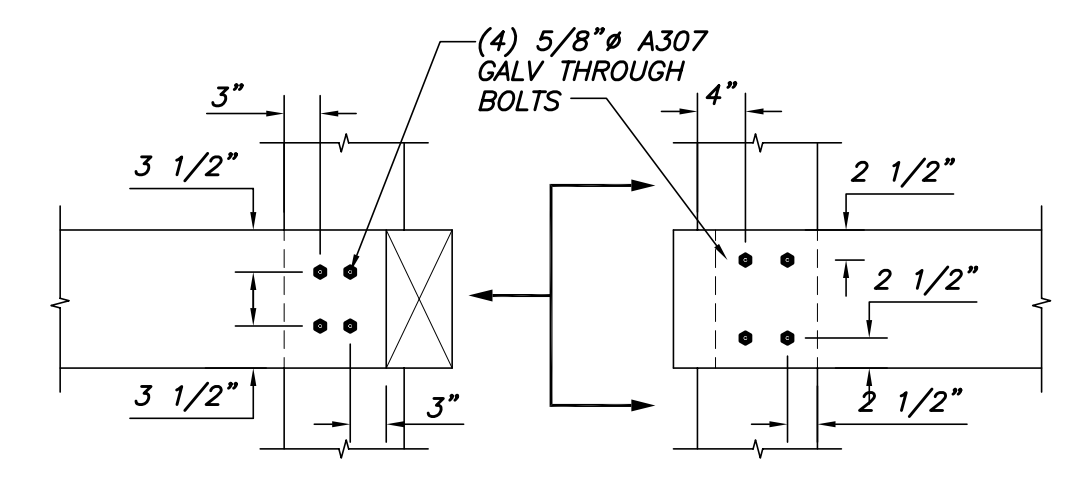

NOTE: DOUGLAS FIR FOR ALL EXTERIOR DECK CONSTRUCTION SHALL BE NO. 1 OR BETTER

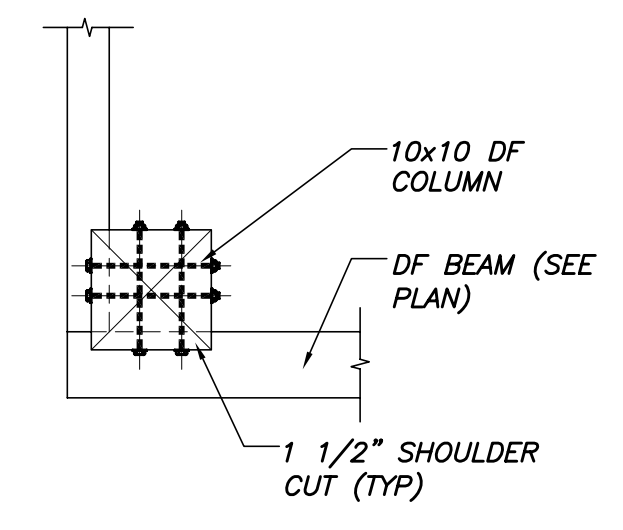

SECTION 8
3/4"=1'-0" S1.4

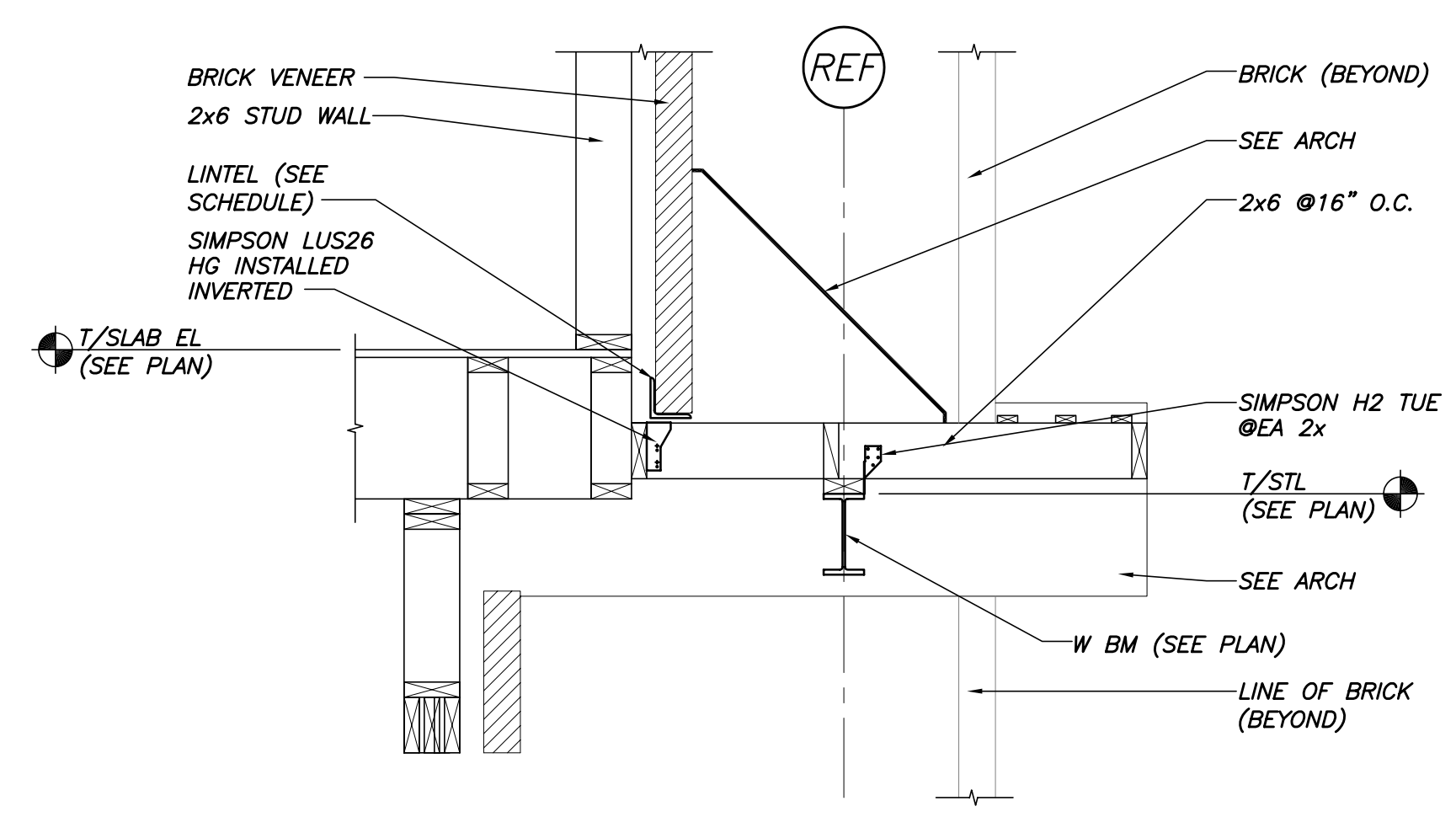

SECTION 9
3/4"=1'-0" S1.2

THIS DRAWING IS AN INSTRUMENT OF SERVICE AND SHALL REMAIN THE PROPERTY OF BECKER STRUCTURAL ENGINEERS INC. IT SHALL NOT BE REPRODUCED, COPIED, LENT OR DISPOSED OF DIRECTLY OR INDIRECTLY NOR USED FOR ANY PURPOSE OTHER THAN FOR WHICH IT IS SPECIFICALLY FURNISHED AND MUST BE RETURNED TO BECKER STRUCTURAL ENGINEERS INC. ON COMPLETION OF WORK, IF REQUESTED.

NOT FOR CONSTRUCTION
PERMIT SET
07/11/2005

Designed	Scale
AMW	NOTED
Drawn	Date
APP	07/11/2005
Checked	Becker Job Number
PBB	1330