

TYPICAL SECTION AT ELEVATOR PIT

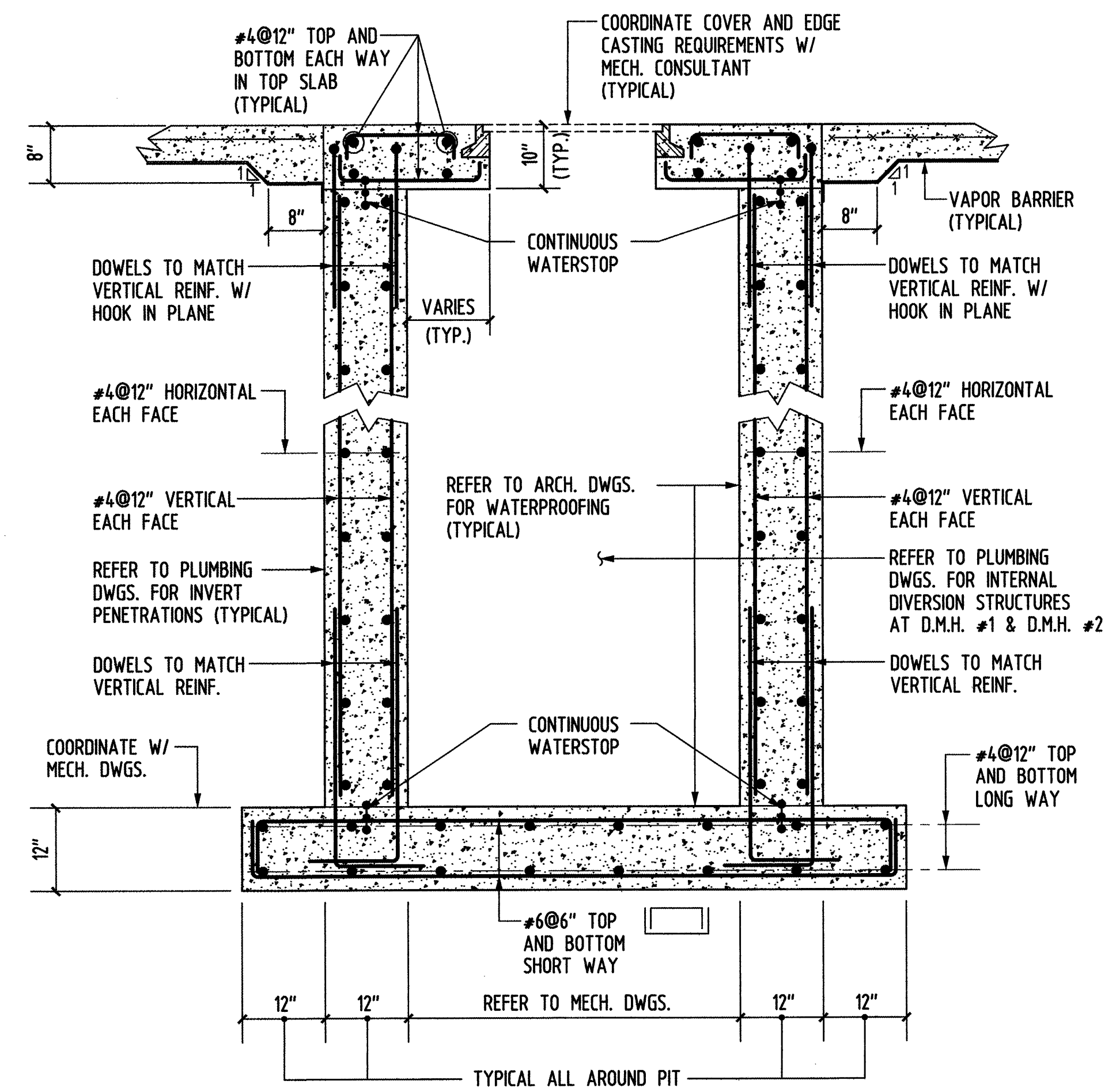

SECTION S2.0 SCALE: 3/4"=1'-0"

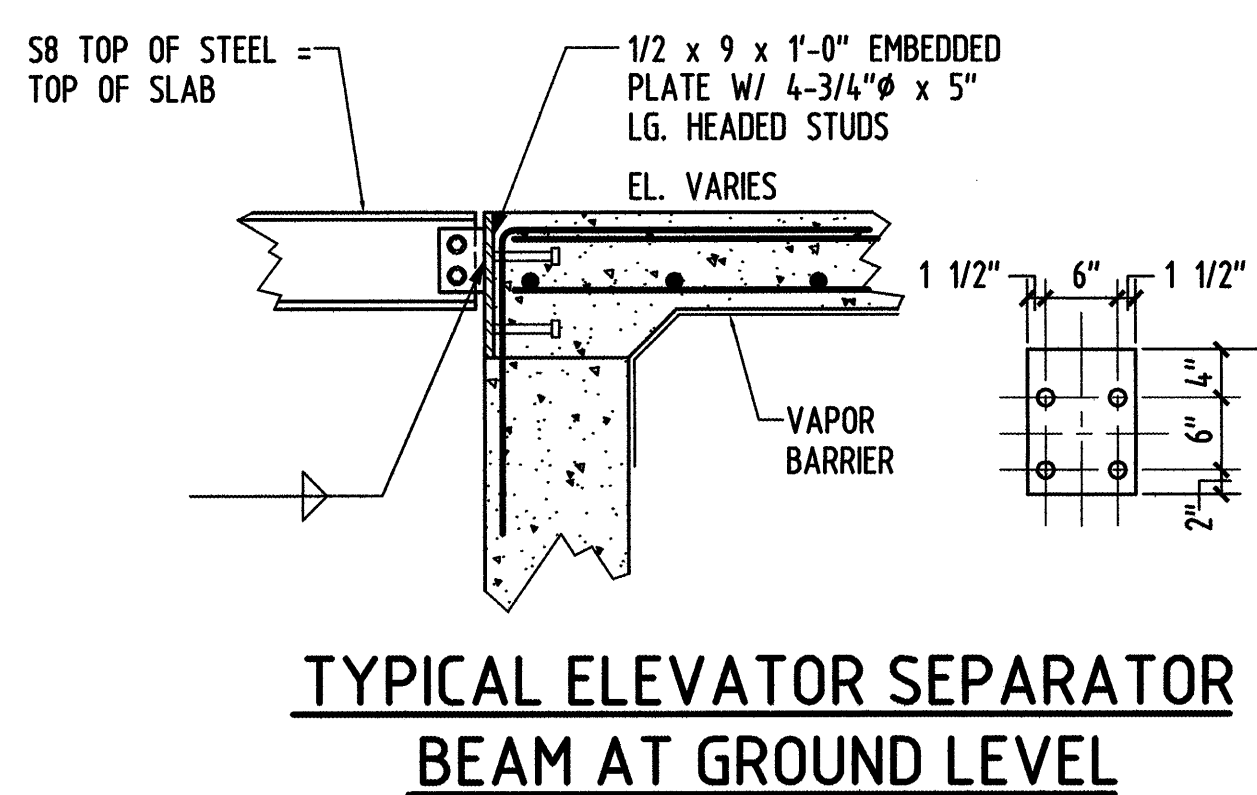

TYPICAL ELEVATOR SEPARATOR BEAM AT GROUND LEVEL

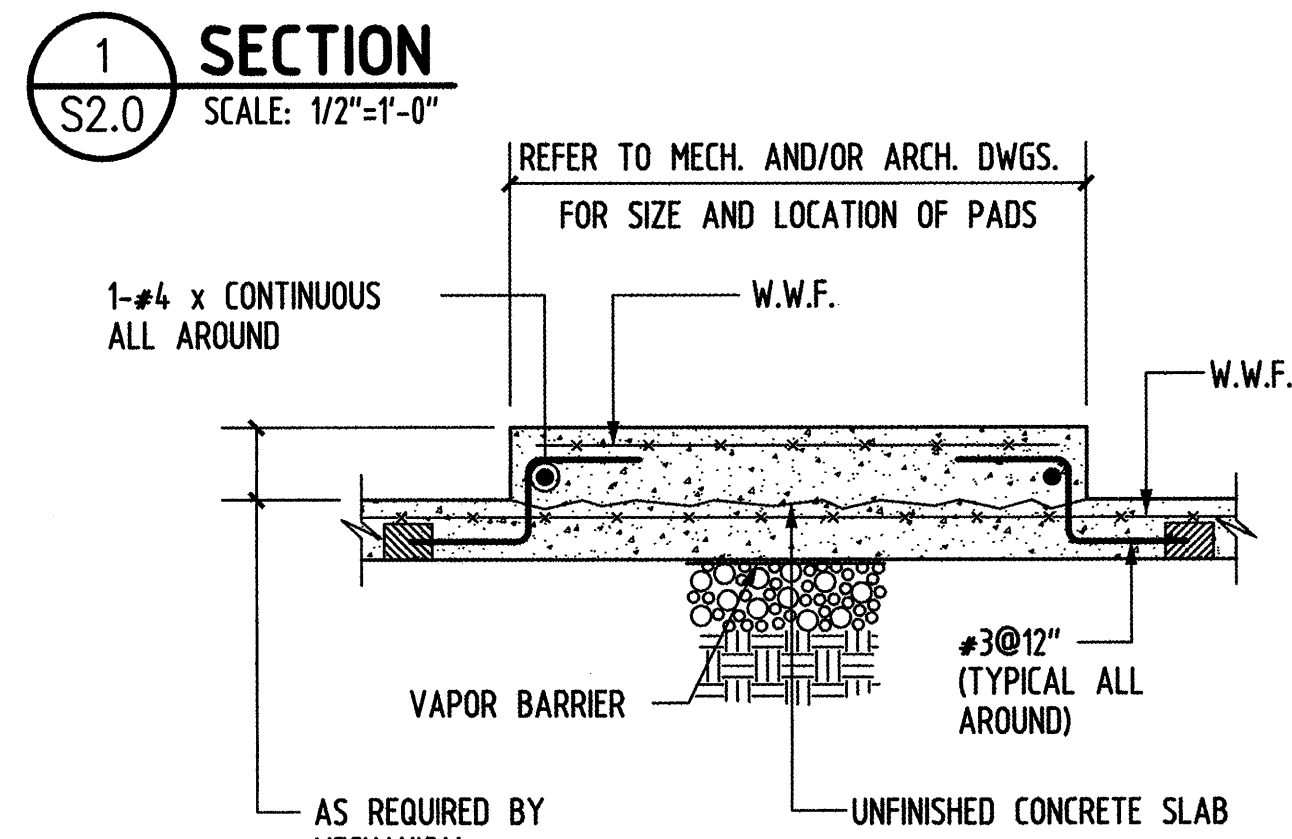

HOUSEKEEPING PAD AT SLAB-ON-GRADE

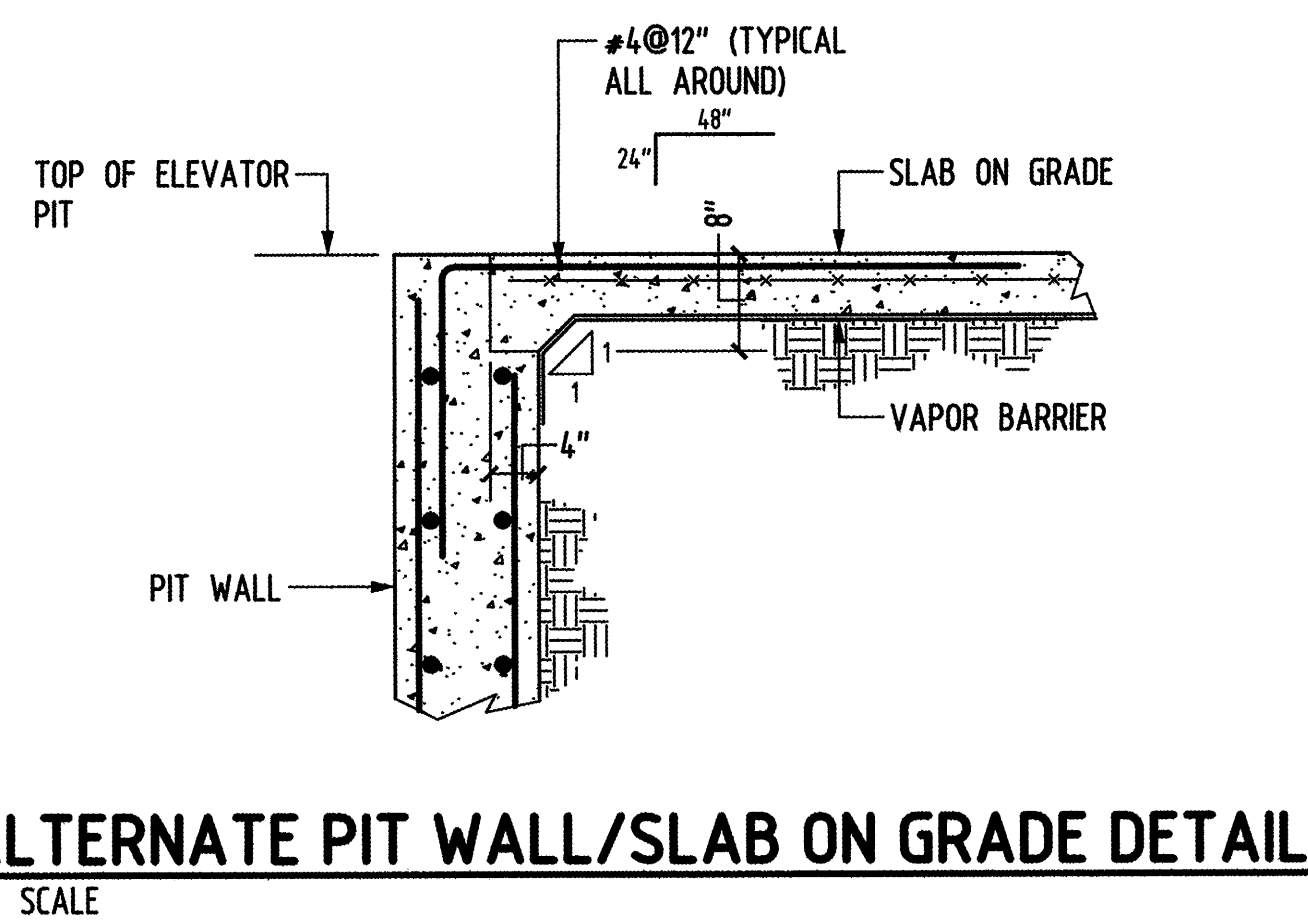

ALTERNATE PIT WALL/SLAB ON GRADE DETAIL NO SCALE

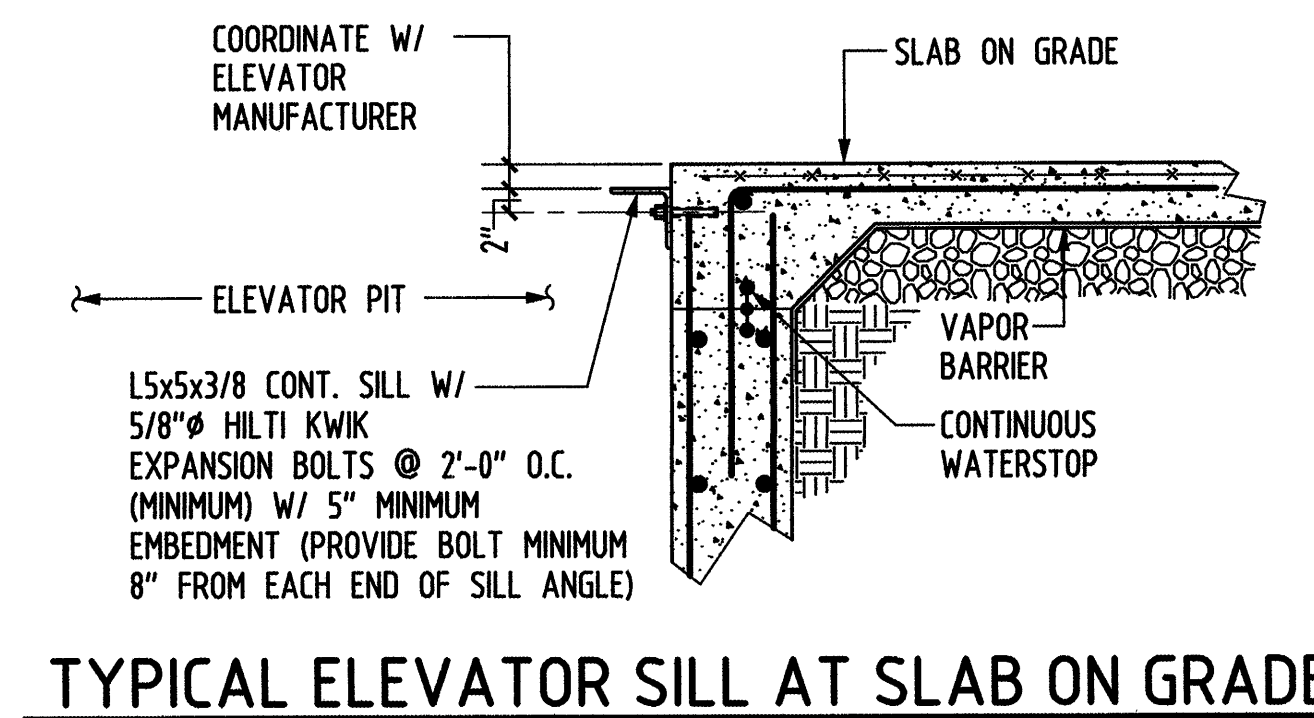

TYPICAL ELEVATOR SILL AT SLAB ON GRADE

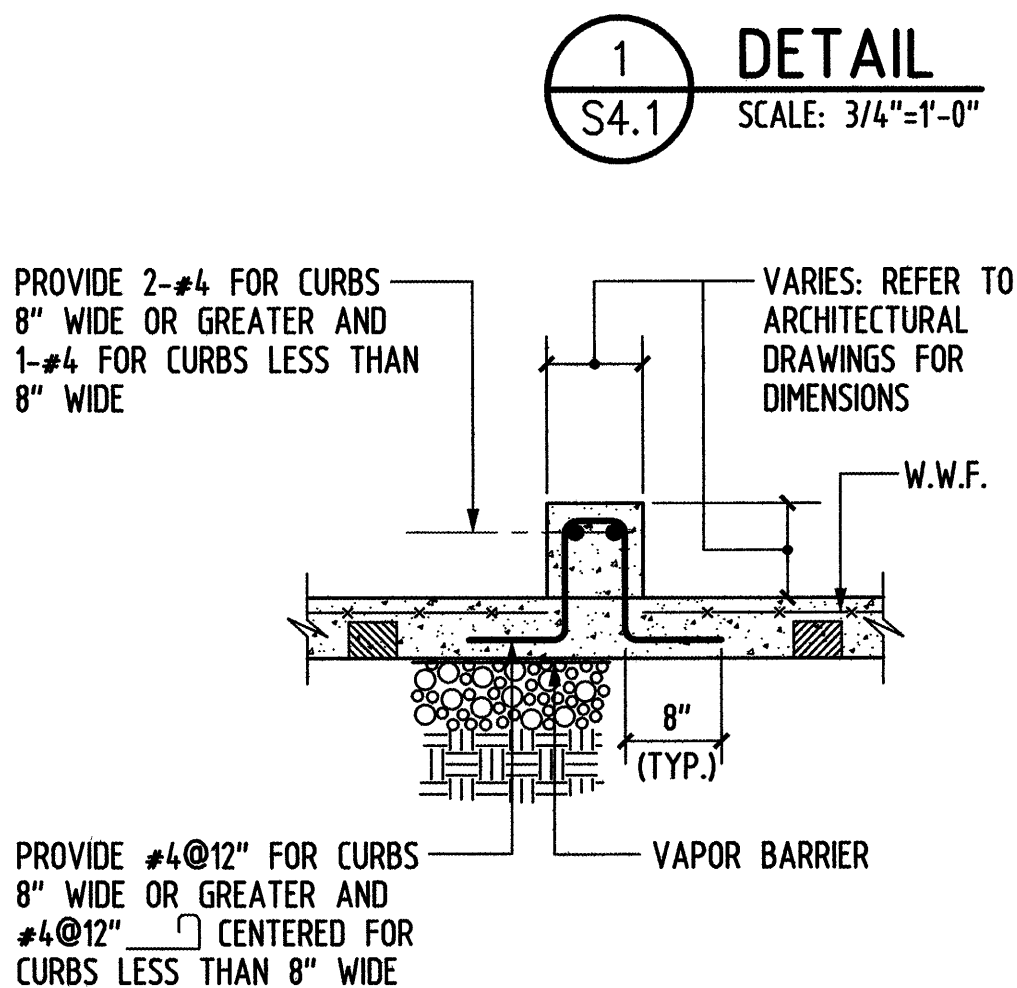

TYPICAL CONCRETE CURB AT SLAB-ON-GRADE

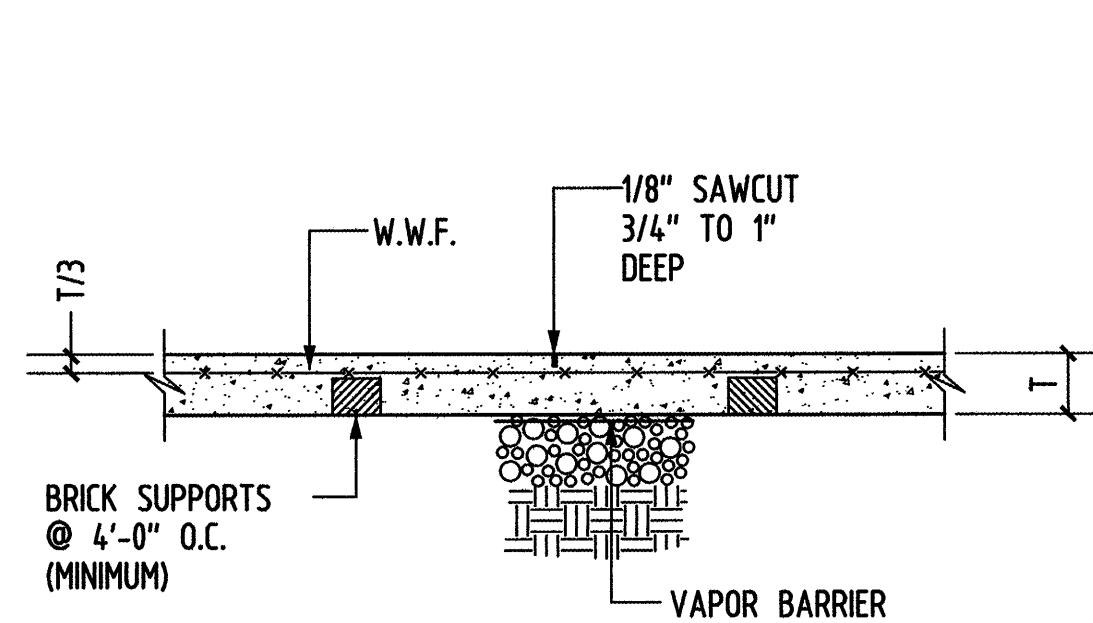

CONTROL JOINT AT SLAB-ON-GRADE

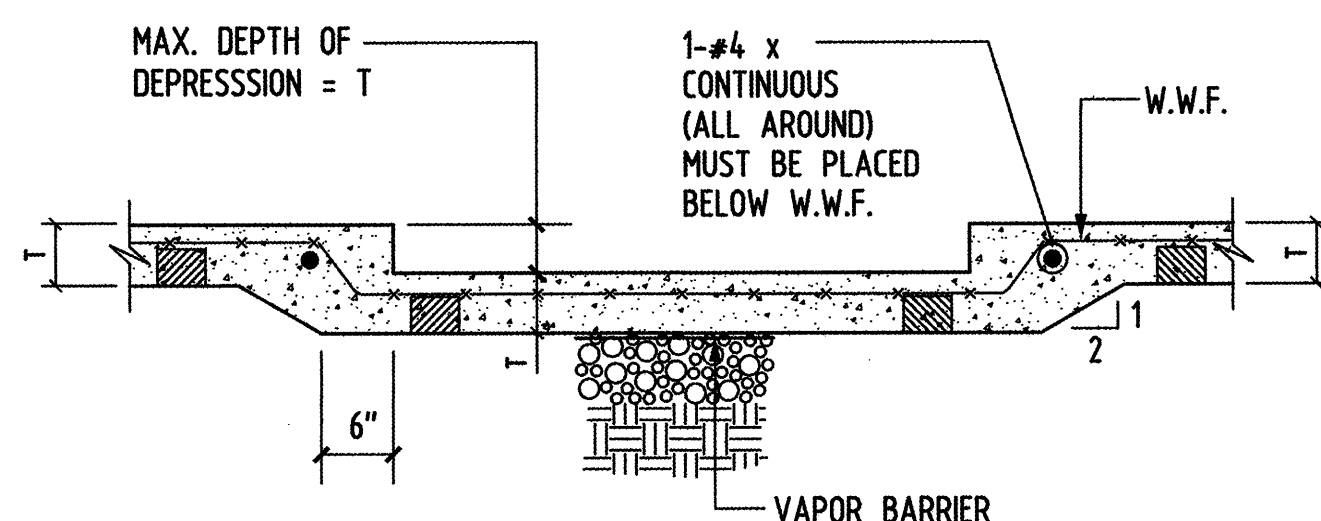

SLAB-ON-GRADE DEPRESSION

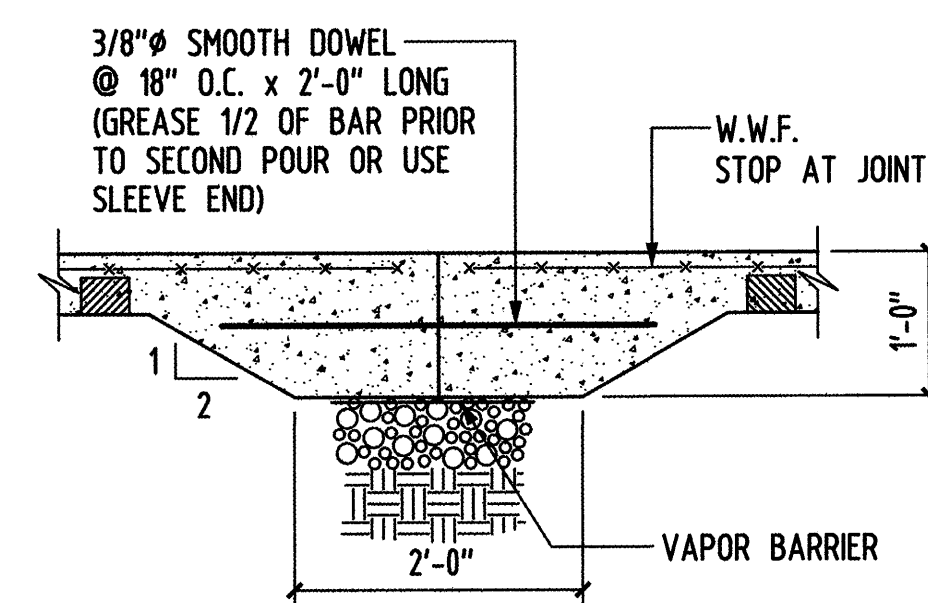

CONSTRUCTION JOINT AT SLAB-ON-GRADE

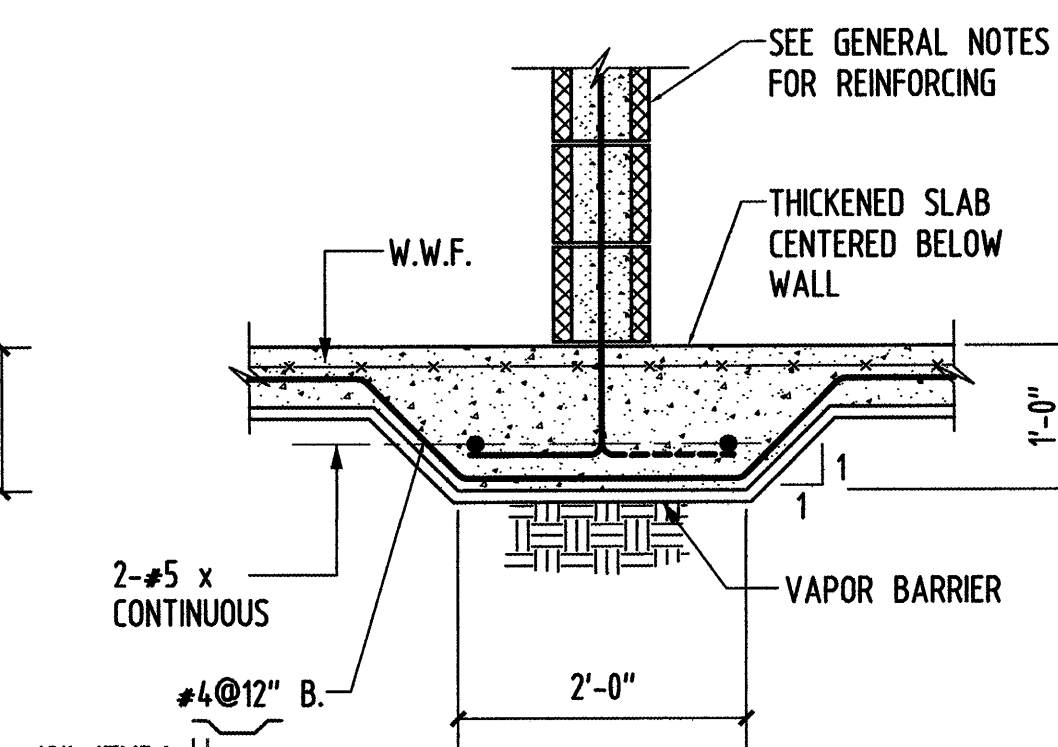

CONTINUOUS TRENCH FOOTING AT CMU WALLS

SECTION S2.0 SCALE: 3/4"=1'-0"

PERMIT ISSUE - 09/27/07

NO.	REVISION	DATE
SCALE: AS NOTED	DRAWN BY: FTV	
DATE: 09/27/07	CHECKED BY: BRG	

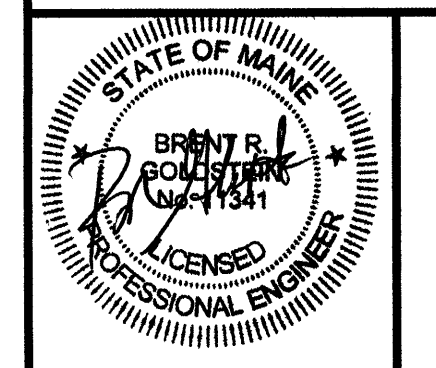

PROJECT
RESIDENCE INN BY MARRIOTT
 PORTLAND, ME.
 JOB # 27089.00

TITLE
CONCRETE DETAILS II

GROUP ONE
 21 W. THIRD STREET, BOSTON, MA 02127
 TEL. (617)268-7000 FAX: (617)268-0209

DRAWING NO.
S4.1