

## COLUMN SCHEDULE

COL. NO.	C1	C2	C3	C4	C5	C6	C7	C8	C9	C10	C11	C12	C13	C14	C15	C16	C17	C18	C19	C20	C21		
LEVEL																							
ROOF EL. VARIES																							ROOF EL. VARIES
SIXTH FLOOR			M10x33		M10x33		M10x33		M10x33		M10x33		M10x33		M10x33		M10x33		M10x33		M10x33		SIXTH FLOOR
FIFTH FLOOR			M10x33		M10x33		M10x33		M10x33		M10x33		M10x33		M10x33		M10x33		M10x33		M10x33		FIFTH FLOOR
FOURTH FLOOR			M10x33		M10x33		M10x33		M10x33		M10x33		M10x33		M10x33		M10x33		M10x33		M10x33		FOURTH FLOOR
THIRD FLOOR			M10x33		M10x33		M10x33		M10x33		M10x33		M10x33		M10x33		M10x33		M10x33		M10x33		THIRD FLOOR
SECOND FLOOR			M10x33		M10x33		M10x33		M10x33		M10x33		M10x33		M10x33		M10x33		M10x33		M10x33		SECOND FLOOR
FIRST FLOOR			M10x33		M10x33		M10x33		M10x33		M10x33		M10x33		M10x33		M10x33		M10x33		M10x33		FIRST FLOOR
BASE PL. TYPE	A	A	A	A	C	A	A	D	A	B	E	A	B	C	B	D	G	D	E	F	E		
BASE PL. SIZE "N" x "L" x "B"	1'-5" x 1" x 0'-9"	1'-5" x 1" x 0'-9"	1'-5" x 1 1/4" x 0'-9"	1'-5" x 1 1/4" x 0'-9"	1'-5" x 1 1/4" x 0'-9"	1'-5" x 1 1/2" x 0'-9"	1'-0" x 1 1/2" x 1'-2"	1'-5" x 1 1/4" x 0'-9"	1'-5" x 1 1/2" x 0'-9"	1'-5" x 1 1/2" x 0'-9"	1'-5" x 3/4" x 0'-9"	1'-5" x 1 1/2" x 0'-9"	1'-5" x 1 3/4" x 0'-9"	1'-5" x 1 3/4" x 0'-11"	1'-5" x 1 3/4" x 0'-11"	2'-6" x 2 1/2" x 30"	1'-5" x 1 3/4" x 0'-11"	1'-5" x 1 3/4" x 0'-11"	1'-6" x 2 1/4" x 18"	1'-5" x 1 1/4" x 0'-9"			

- COLUMN SCHEDULE NOTES:**
- ALL COLUMN STEEL SHALL BE ASTM A572 GRADE 50.
  - ALL BASE PL. STEEL SHALL BE ASTM A36.
  - GRAVITY COLUMN SPLICES SHALL BE 4'-6" A.F.F.
  - CONTRACTOR OPTION TO OMIT UPPER MOST SPLICE

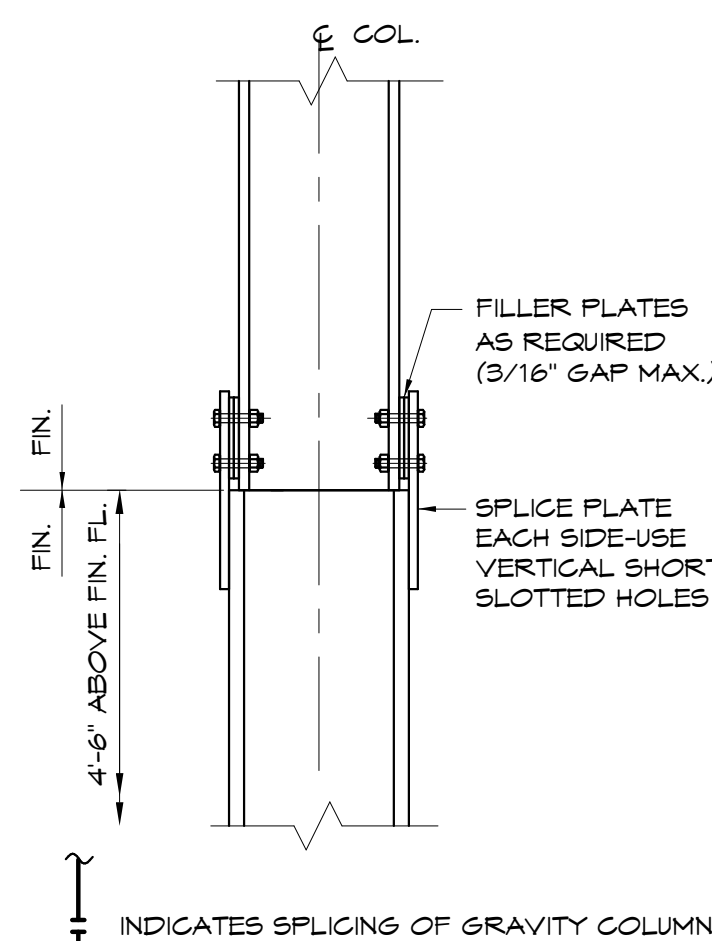

**TYPICAL COLUMN SPLICE DETAIL**

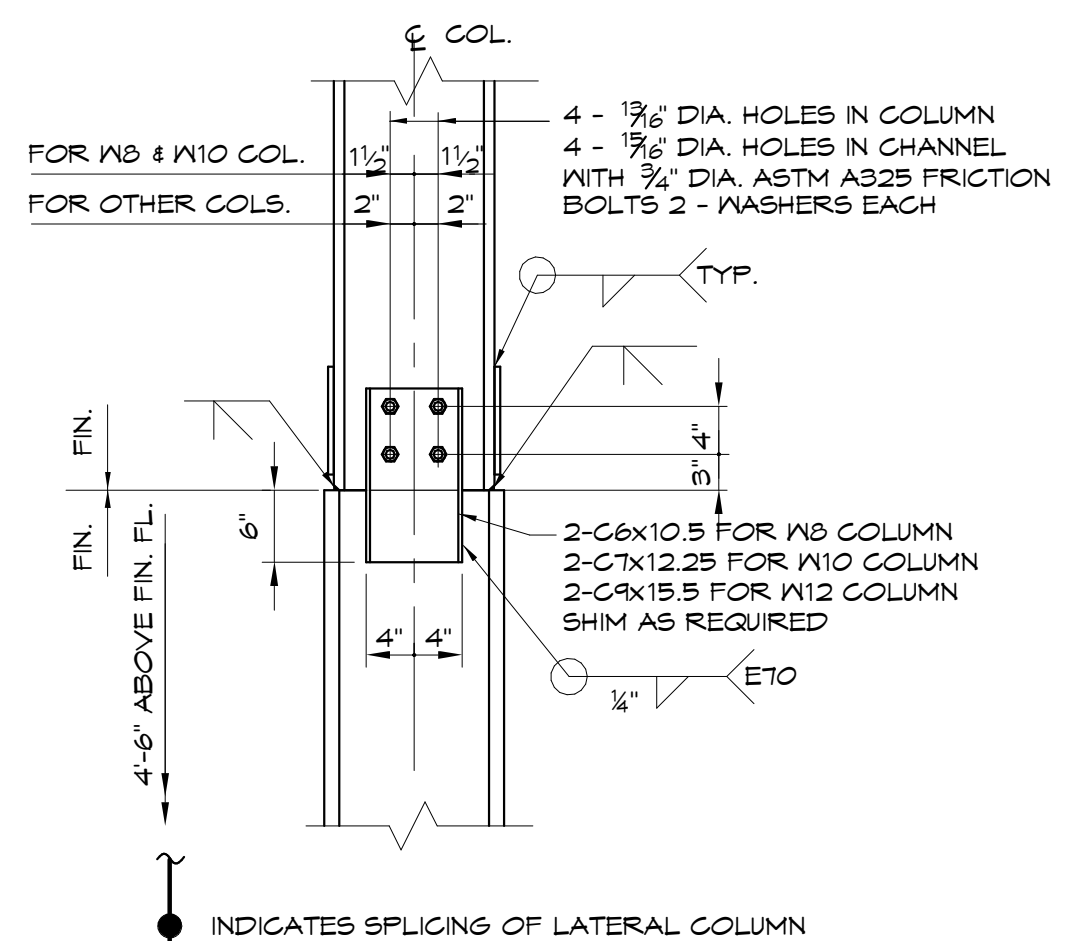

**BRACE AND MOMENT FRAME COLUMN SPLICE DETAIL**

**STRUCTURAL STEEL COLUMN SPLICE DETAILS**

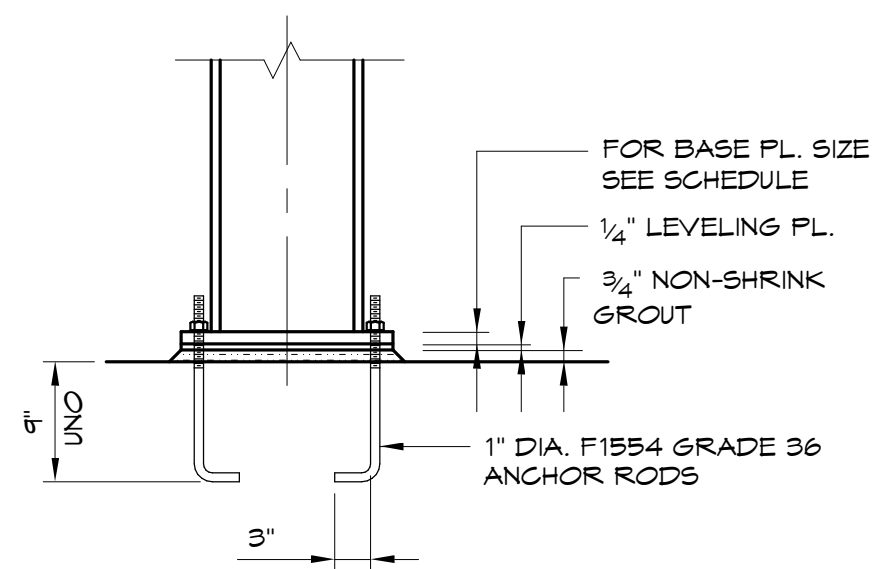
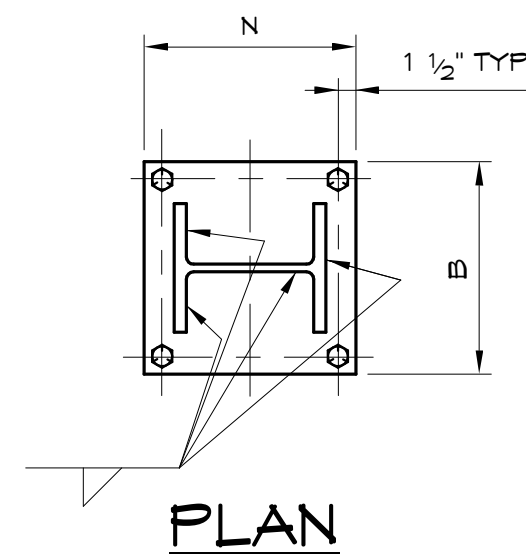

**BASE PLATE TYPE 'A'**

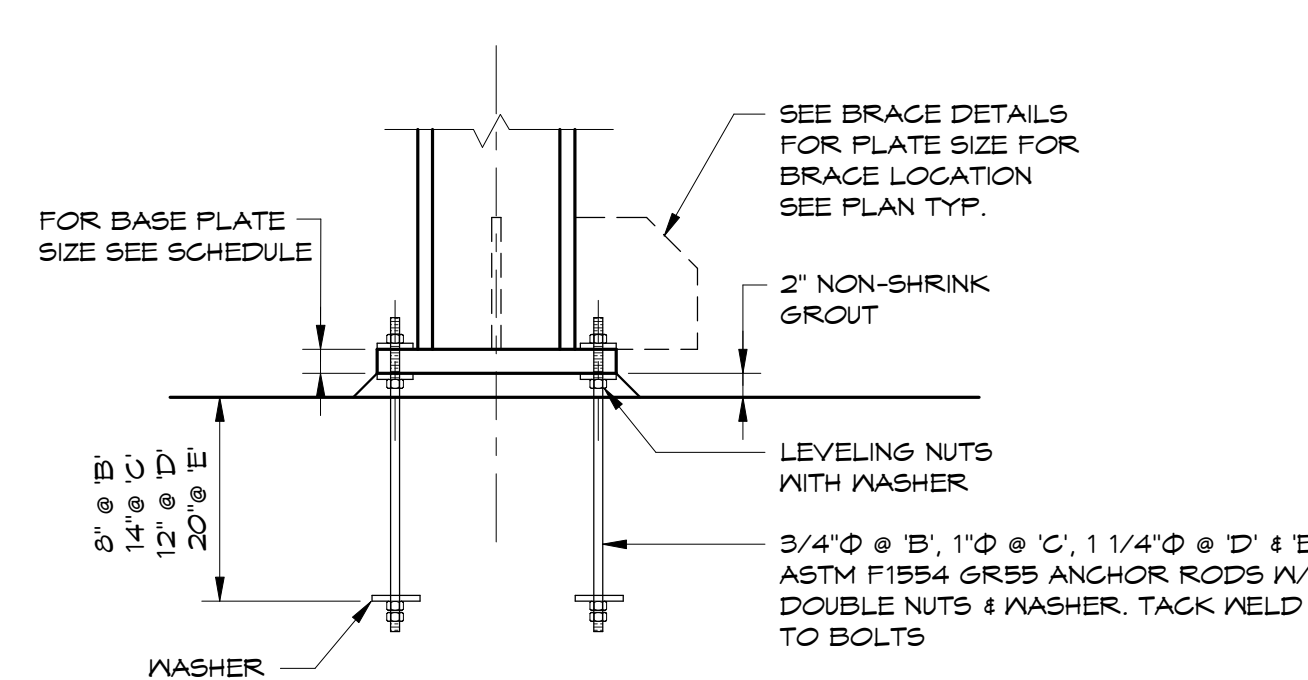
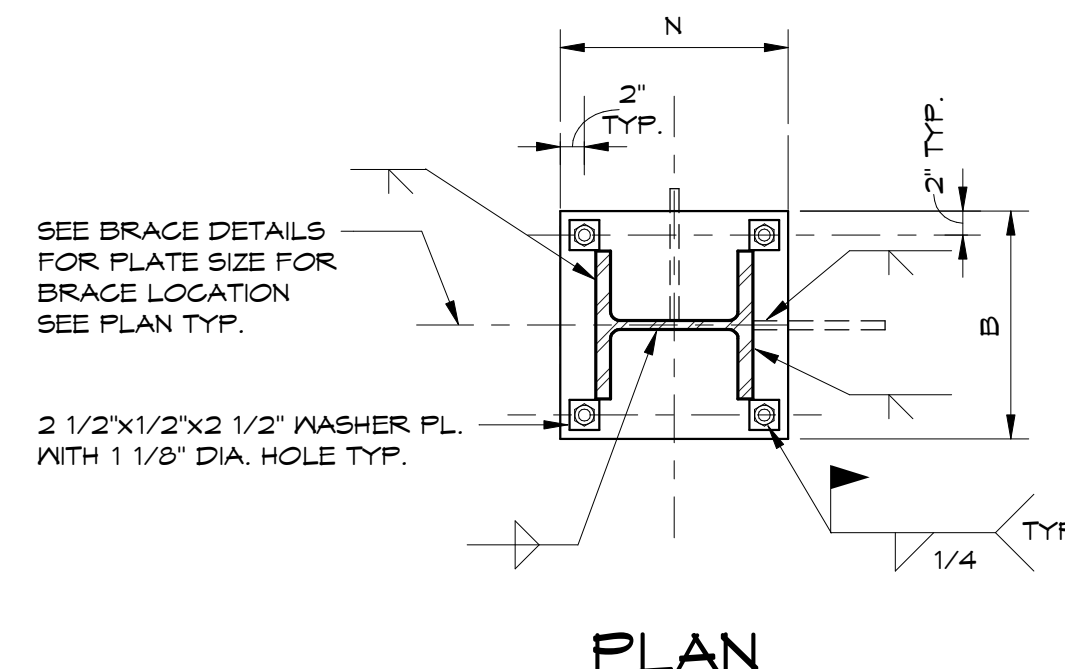

**BASE PLATE TYPES 'B', 'C', 'D', & 'E'**

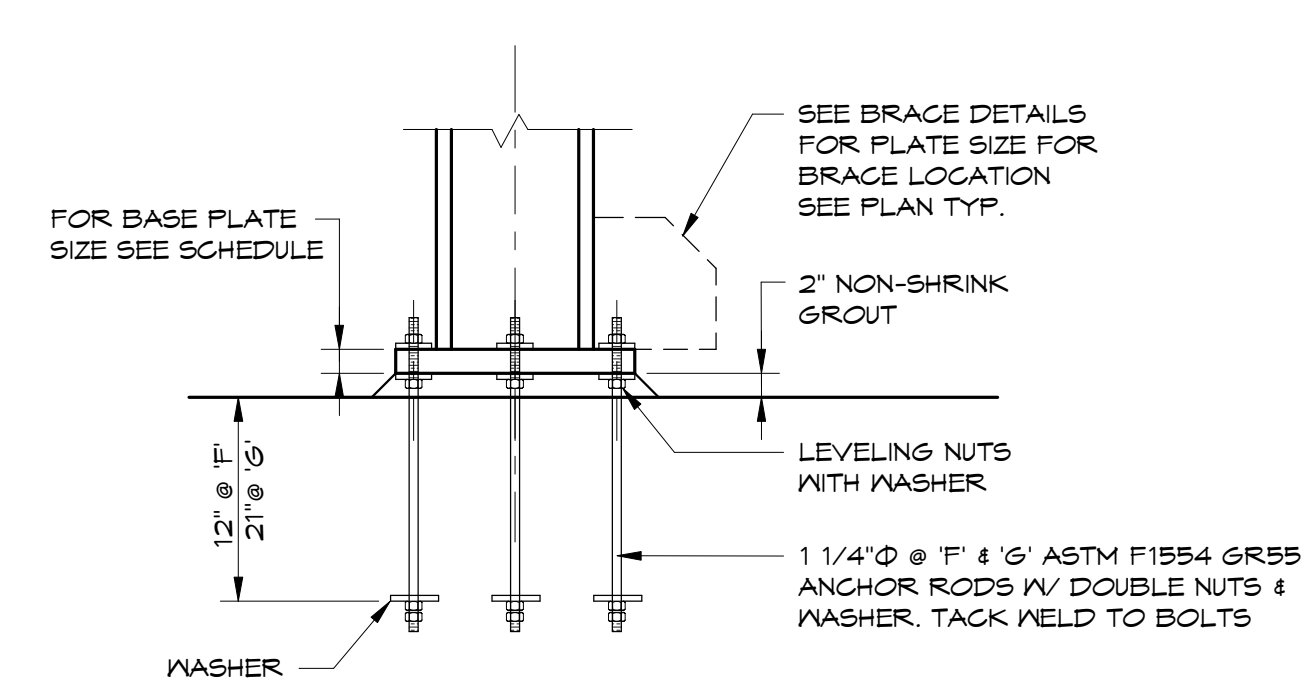
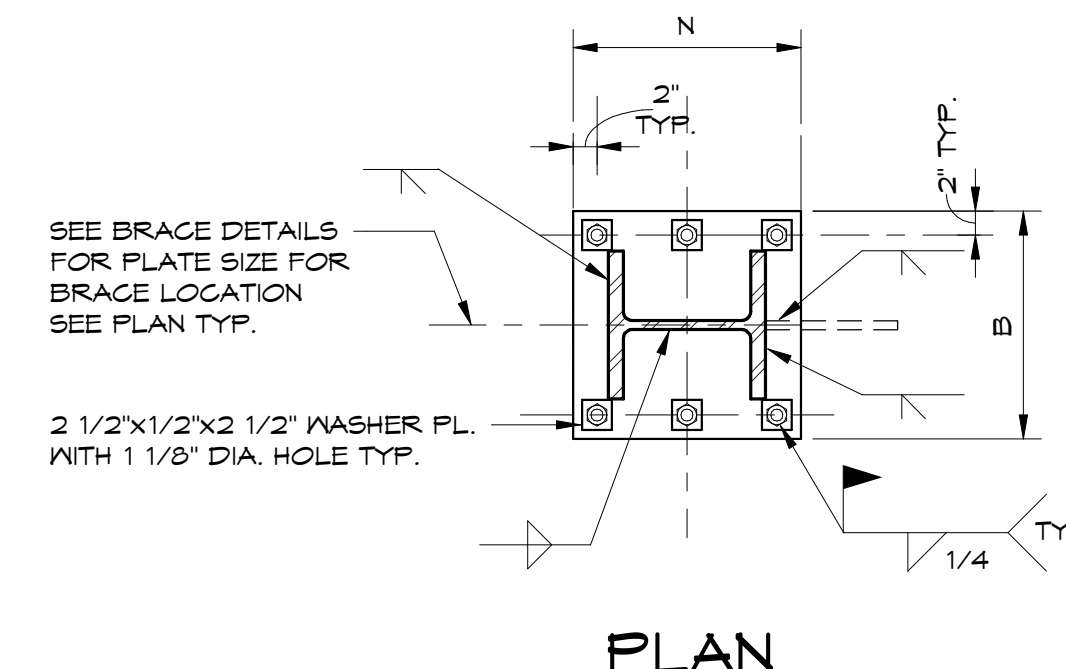

**BASE PLATE TYPES 'F', & 'G'**

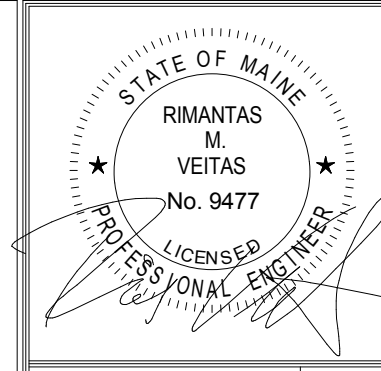

Prepared For:  
**EssexNorth  
Portland LLC**  
P.O. Box 394  
Topsfield, MA 01983

Consultant:  
**VEITAS VEITAS  
engineers**  
630 Centre Street, Suite 101  
Braintree, Massachusetts 02184  
TEL: 781-843-2863 FAX: 781-849-2055

Architect:  
**ARCHETYPE  
architects**  
48 Union Wharf Portland, Maine 04101  
(207) 772-6022 Fax (207) 772-4056

Project:  
**THAMES STREET  
CONDOMINIUM**  
20 Thames Street, Portland Maine

Revisions:  
1. 06/30/17 Steel Bid - Addendum #1  
2. 07/21/17 BID SET

Date: JULY 2017  
Scale: As indicated  
**COLUMN SCHEDULE,  
BASE PLATE & PIER  
DETAILS**

**S3.01**