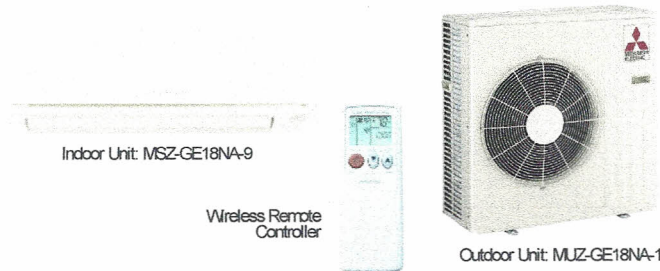

SUBMITTAL DATA: MSZ-GE18NA-9 & MUZ-GE18NA-1

18,000 BTU/H WALL-MOUNTED HEAT-PUMP SYSTEMS

Job Name:
System Reference:
Date:

GENERAL FEATURES

- Wall-mounted indoor unit
- Standard Hybrid Catechin Pre-filter is included with indoor unit
- Quiet operation
- Auto fan speed control: Quiet, Low, Medium, High, and Super High
- Hand-held Wireless Remote Controller
- Indoor unit powered from outdoor unit using A-Control
- Auto restart following a power outage
- Base heater is available as an option
- Anti-allergy Enzyme Filter
- Limited warranty: five years parts and seven years compressor

ACCESSORIES
Outdoor Unit

- Base Heater (MAC-641BH-U)
- Drain Socket Assembly (MAC-811DS)

Indoor Unit

- Condensate Pump (230V; SI3100-230)

Controller Options

- Wireless Wall-mounted Remote Controller Kit (MHK1)*
- Portable Central Controller (MCCH1)*
- Outdoor Air Sensor (MOS1)*
- Wired Wall-mounted Controller (PAR-31MAA requires MAC-333IF)*
- Simple MA Remote Controller (PAC-YT53CRAU requires MAC-333IF)*

*See Submittal for information on each option.

- System Control Interface (MAC-333IF)
- Remote Temperature Sensor (M21-JKO-307)
- Lockdown Bracket for Hand-held Controller (RCMKP1CB)



DIMENSIONS: MSZ-GE18NA-9 & MUZ-GE18NA-1

MSZ-GE18NA-9

Unit: inch

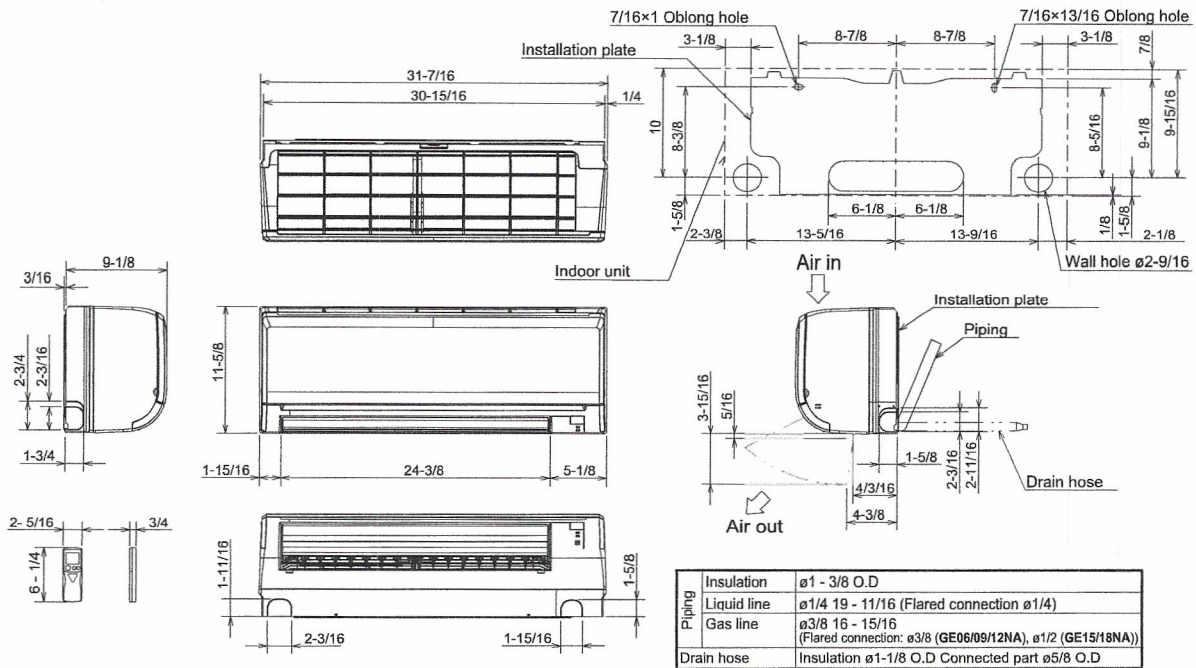

MUZ-GE18NA-1

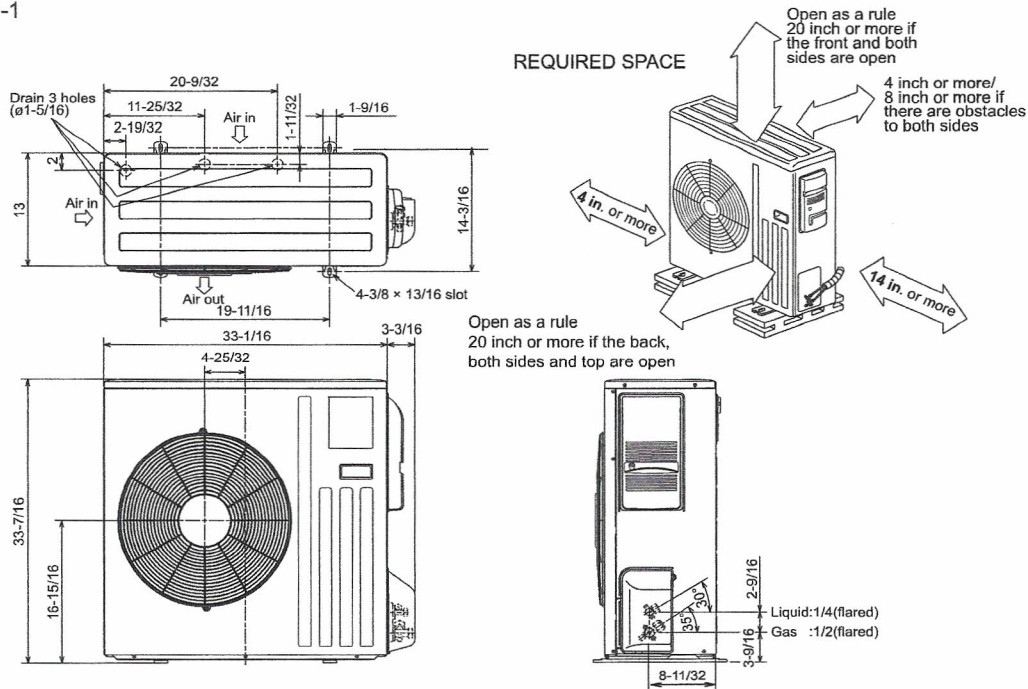

1340 Satellite Boulevard
 Suwanee, GA 30024
 Toll Free: 800-433-4822
 www.mehvac.com