

DISPLAY THIS CARD ON PRINCIPAL FRONTAGE OF WORK



CITY OF PORTLAND BUILDING PERMIT

This is to certify that R.M. Pearson, Inc.
of 232 Ossipee Trail, Gorham, ME 04038

For installation at 150 CONGRESS ST
8-Family

Job ID: 2011-11-2621-FAFS

CBL: 017-A-002-001

has permission to install option 2 supervised fire alarm system
provided that the person or persons, firm or corporation accepting this permit shall comply with all of the provisions of
the Statues of Maine and of the Ordinances of the City of Portland regulating the construction, maintenance and use of
the buildings and structures, and of the application on file in the department.

Notification of inspection and written permission procured
before this building or part thereof is lathed or otherwise
closed-in. 48 HOUR NOTICE IS REQUIRED.

A final inspection must be completed by owner
before this building or part thereof is occupied. If a
certificate of occupancy is required, it must be

58

Fire Prevention Officer

Code Enforcement Officer / Plan Reviewer

THIS CARD MUST BE POSTED ON THE STREET SIDE OF THE PROPERTY
PENALTY FOR REMOVING THIS CARD

BUILDING PERMIT INSPECTION PROCEDURES

Please call 874-8703 or 874-8693 (ONLY)

or email: buildinginspections@portlandmaine.gov

With the issuance of this permit, the owner, builder or their designee is required to provide adequate notice to the city of Portland Inspections Services for the following inspections. Appointments must be requested 48 to 72 hours in advance of the required inspection. The inspection date will need to be confirmed by this office.

- **Please read the conditions of approval that is attached to this permit!! Contact this office if you have any questions.**
- **Permits expire in 6 months. If the project is not started or ceases for 6 months.**
- **If the inspection requirements are not followed as stated below additional fees may be incurred due to the issuance of a "Stop Work Order" and subsequent release to continue.**

Final Fire

The project cannot move to the next phase prior to the required inspection and approval to continue, REGARDLESS OF THE NOTICE OF CIRCUMSTANCES.

IF THE PERMIT REQUIRES A CERTIFICATE OF OCCUPANCY, IT MUST BE PAID FOR AND ISSUED TO THE OWNER OR DESIGNEE BEFORE THE SPACE MAY BE OCCUPIED.



PORTLAND MAINE

Strengthening a Remarkable City, Building a Community for Life • www.portlandmaine.gov

Director of Planning and Urban Development

Penny St. Louis

Job ID: 2011-11-2621-FAFS
Install option 2 supervised fire alarm
system

For installation at:
150 CONGRESS ST
8-Family

CBL: 017- A-002-001

Conditions of Approval:

Fire

The hallways do require heat detection. If open to the dining rooms (no doors or deep headers) those heat detectors may suffice if within the spacing requirements.

The only exemption to the heat detectors is bathrooms less than 55 ft/sq and closets less than 24 ft/sq and with a maximum depth of 3 ft. The rooms directly over the front hall on floors 2, 3 and 4 require heat detection.

A system commissioning 75 dBA must be verified at the pillow in every sleeping room with all doors closed, and documentation shall be provided.

The fire alarm system shall comply with the City of Portland Standard for Signaling Systems for the Protection of Life and Property. All fire alarm installation and servicing companies shall have a Certificate of Fitness from the Fire Department.

In field installation shall be installed per code as conditions dictate.

Records cabinet, FACP, annunciator(s), and pull stations shall be keyed alike.

Central Station monitoring for addressable fire alarm systems shall be by point.

All fire alarm records required by NFPA 72 should be stored in an approved cabinet located at the FACP labeled "FIRE ALARM RECORDS".

A Model 4100 Knox Box is required.

The fire alarm system shall be certified by a master fire alarm company and have a new fire alarm inspection sticker.

System acceptance and commissioning must be coordinated with alarm and suppression system contractors and the Fire Department. Call 874-8703 to schedule.

Fire Alarm system shall be maintained. If system is to be off line over 4 hours a fire watch shall be in place. Dispatch notification required 874-8576.

No master box is permitted by City Ordinance.

City of Portland, Maine - Building or Use Permit Application

389 Congress Street, 04101 Tel: (207) 874-8703, FAX: (207) 8716

Job No: 2011-11-2621-FAFS	Date Applied: 10/26/2011	CBL: 017- A-002-001	
Location of Construction: 150 CONGRESS ST	Owner Name: REBECCA RICE	Owner Address: 658 CONGRESS ST 1ST FLOOR PORTLAND, ME 04101	Phone:
Business Name:	Contractor Name: PROTECTION PROFESSIONALS,	Contractor Address: 325 US 1- FALMOUTH MAINE 04105	Phone: (207) 775-5755 (207) 329-8432
Lessee/Buyer's Name:	Phone:	Permit Type: FIRE ALARM	Zone: R-6
Past Use: Eight residential dwelling units	Proposed Use: Same: eight residential dwelling units – to install fire alarm	Cost of Work: \$6,000.00	CEO District:
		Fire Dept: <input checked="" type="checkbox"/> Approved w/conditions <input type="checkbox"/> Denied <input type="checkbox"/> N/A	Inspection: Use Group: Type:
		Signature: <i>[Signature]</i> (58)	Signature:
Proposed Project Description: Install Fire Alarm Entire Building		Pedestrian Activities District (P.A.D.)	
Permit Taken By: Lannie		Zoning Approval	

<p>1. This permit application does not preclude the Applicant(s) from meeting applicable State and Federal Rules.</p> <p>2. Building Permits do not include plumbing, septic or electrical work.</p> <p>3. Building permits are void if work is not started within six (6) months of the date of issuance. False informatin may invalidate a building permit and stop all work.</p>	<p>Special Zone or Reviews</p> <p><input type="checkbox"/> Shoreland</p> <p><input type="checkbox"/> Wetlands</p> <p><input type="checkbox"/> Flood Zone</p> <p><input type="checkbox"/> Subdivision</p> <p><input type="checkbox"/> Site Plan</p> <p><input type="checkbox"/> Maj <input type="checkbox"/> Min <input checked="" type="checkbox"/> MM</p> <p>Date: <i>OK 11/7/11</i></p>	<p>Zoning Appeal</p> <p><input type="checkbox"/> Variance</p> <p><input type="checkbox"/> Miscellaneous</p> <p><input type="checkbox"/> Conditional Use</p> <p><input type="checkbox"/> Interpretation</p> <p><input type="checkbox"/> Approved</p> <p><input type="checkbox"/> Denied</p> <p>Date:</p>	<p>Historic Preservation</p> <p><input checked="" type="checkbox"/> Not in Dist or Landmark</p> <p><input type="checkbox"/> Does not Require Review</p> <p><input type="checkbox"/> Requires Review</p> <p><input type="checkbox"/> Approved</p> <p><input type="checkbox"/> Approved w/Conditions</p> <p><input type="checkbox"/> Denied</p> <p>Date: <i>[Signature]</i></p>
	CERTIFICATION		

I hereby certify that I am the owner of record of the named property, or that the proposed work is authorized by the owner of record and that I have been authorized by the owner to make this application as his authorized agent and I agree to conform to all applicable laws of this jurisdiction. In addition, if a permit for work described in the application is issued, I certify that the code official's authorized representative shall have the authority to enter all areas covered by such permit at any reasonable hour to enforce the provision of the code(s) applicable to such permit.

SIGNATURE OF APPLICANT	ADDRESS	DATE	PHONE
RESPONSIBLE PERSON IN CHARGE OF WORK, TITLE		DATE	PHONE



Fire Alarm Permit

If you or the property owner owes real estate or property taxes or user charges on any property within the city, payment arrangements must be made before permits of any kind are accepted.

Installation address: 150 Congress St. CBL: 17A2 R-6
 Exact location: (within structure) ENTIRE BLDG. BDU per 1955
 Type of occupancy(s) (NFPA & ICC): MULTI-FAMILY Street DU
 Building owner: GEOFFRAY RICE
 System Designer (point of contact): PROTECTION PROFESSIONALS
 Designer phone: 775-5755 E-mail: RICE@PROTECTIONPROFESSIONALS.COM
 Installing contractor: R.M. PEARSON, INC Certificate of Fitness No: W1035
 Contractor phone: 839-3223 (CELL 329-8432) E-mail: rpearso1@MAINE.MA.COM

This is a new application: YES NO
 This is an amendment to an existing permit: YES NO Permit no: _____

The following documents shall be provided with this application:

- Floor plans
- Wiring diagram
- Annunciator details
- Equipment data sheets
- Battery & voltage drop calculations
- Input/ Output Matrix
- Designer qualifications
- Electrical Permit Pulled (check alarm/com)

RECEIVED
 OCT 26 2011
 Dept. of Building Inspections
 City of Portland Maine

COST OF WORK: \$6,000.00
 PERMIT FEE: 80
 (\$10 PER \$1,000 + \$30 FOR THE FIRST \$1,000)

11.3.11

The **designer** shall be the responsible party for this application. Download a new copy of this application at www.portlandmaine.gov/fire for every submittal. Submit all plans in electronic PDF in addition to full sized plans to the Building Inspections Department, 389 Congress Street, Room 315, Portland, Maine 04101.

Prior to acceptance of any fire alarm system, a complete commissioning and acceptance test must be coordinated with all fire system contractors and the Fire Department, and proper documentation of such test(s) provided.

All installation(s) must comply with the *City of Portland Technical Standard for Signaling Systems for the Protection of Life and Property*, available at www.portlandmaine.gov/fire.

Applicant signature: Robert M. Pearson Date: 10/26/11



CITY OF PORTLAND, MAINE

Department of Building Inspections

Original Receipt

10-26 20 11

Received from R M Pen

Location of Work 150 Congress

Cost of Construction \$ 40,000 Building Fee: _____

Permit Fee \$ _____ Site Fee: _____

Certificate of Occupancy Fee: _____

Total: _____

Building (IL) _____ Plumbing (I5) _____ Electrical (I2) _____ Site Plan (U2) _____

Other Plumbing 50

CBL: 17112 20

Check #: _____ Total Collected \$ 135

**No work is to be started until permit issued.
Please keep original receipt for your records.**

Taken by: [Signature]

WHITE - Applicant's Copy
YELLOW - Office Copy
PINK - Permit Copy

ELECTRICAL PERMIT

City of Portland, Me.



To the Chief Electrical Inspector, Portland Maine:
 The undersigned hereby applies for a permit to make electrical installations
 in accordance with the laws of Maine, the City of Portland Electrical Ordinance,
 National Electrical Code and the following specifications:

Date _____
 Permit # _____
 CBL# 17A2

LOCATION: 150 CONGRESS ST. METER MAKE & # _____
 CMP ACCOUNT # _____ OWNER Geoffrey Rice
 TENANT _____ PHONE # _____

					TOTAL EACH FEE	
OUTLETS	Receptacles	Switches	Smoke Detector		.20	
FIXTURES	Incandescent	Fluorescent	Strips		.20	
SERVICES	Overhead	Underground	TTL AMPS <800		15.00	
	Overhead	Underground	TTL AMPS >800		25.00	
Temporary Service	Overhead	Underground	TTL AMPS		25.00	
					25.00	
METERS	(number of)				1.00	
MOTORS	(number of)				2.00	
RESID/COM	Electric units				1.00	
HEATING	oil/gas units	Interior	Exterior		5.00	
APPLIANCES	Ranges	Cook Tops	Wall Ovens		2.00	
	Insta-Hot	Water heaters	Fans		2.00	
	Dryers	Disposals	Dishwasher		2.00	
	Compactors	Spa	Washing Machine		2.00	
	Others (denote)				2.00	
	MISC. (number of)	Air Cond/win			3.00	
		Air Cond/cent		Pools	10.00	
		HVAC	EMS	Thermostat	5.00	
	Signs			10.00		
	Alarms/res			5.00		
	X Alarms/com			15.00		
	Heavy Duty(CRKT)			2.00		
	Circus/Carnv			25.00		
	Alterations			5.00		
	Fire Repairs			15.00		
	E Lights			1.00		
	E Generators			20.00		
PANELS	Service	Remote	Main		4.00	
TRANSFORMER	0-25 Kva				5.00	
	25-200 Kva				8.00	
	Over 200 Kva				10.00	
TOTAL AMOUNT DUE						
MINIMUM FEE/COMMERCIAL 55.00					MINIMUM FEE	45.00

RECEIVED
 OCT 26 2011
 Dept. of Building Inspection
 City of Portland, Maine

CONTRACTORS NAME R. M. Pearson, Inc MASTER LIC. # MS6000 4434
 ADDRESS 232 OSSIPPE TRAILS LIMITED LIC. # _____
 TELEPHONE 329-8432

SIGNATURE OF CONTRACTOR R. M. Pearson

Benjamin Wallace - Re: 150 Congress Street

From: Benjamin Wallace
To: Rich Brobst
Date: 10/19/2011 11:01 AM
Subject: Re: 150 Congress Street
CC: Bob Pearson
Attachments: Benjamin Wallace.vcf

1. The hallways do require heat detection. If open to the dining rooms (no doors or deep headers) those heat detectors may suffice if within the spacing requirements.
2. The only exemption to the heat detectors is bathrooms less than 55 ft/sq and closets less than 24 ft/sq and with a maximum depth of 3 ft. The front rooms would appear to require the heats.
3. Ok. A meter will need to verify the DB at the pillows at the end of the job.
4. Thanks.
5. Ok

Ben

Lt. Benjamin Wallace Jr.
Fire Prevention Officer
Portland Fire Department
380 Congress Street
Portland, Maine 04101
(207)874-8400
wallaceb@portlandmaine.gov

>>> Rich Brobst <rich@protectionprofessionals.net> 10/19/2011 10:49 AM >>>
Good day:

Thank you for your comments. Please note my clarifications:

1. We did not supply heat detection in the hallways. I did not think it would be necessary. I thought we only had to cover the rooms.
2. The rooms directly above the front halls and the bathrooms are less than 55 s.f. We did not supply heats for these rooms.
3. We feel that the horn/strobes in the hallways will meet the 75 decibel requirement at the pillows. We did not supply additional devices inside the units.
4. Please note updated documents for the wireless detectors and the matrix. Sorry for the incomplete data.
5. The customer is supplying all of the Knox boxes for Rice Properties. I will pass on the specifications that are noted below.

Thank you for your time;

*Rich Brobst, Jr
NICET III
Master Electrician
Protection Professionals
325 US Route One*

Falmouth, Maine 04105
207-775-5755
Cell: 207-899-7761

From: "Benjamin Wallace" <wallaceb@portlandmaine.gov>
To: "Rich Brobst" <rich@protectionprofessionals.net>
Cc: "Bob Pearson" <rpearso1@maine.rr.com>
Sent: Wednesday, October 19, 2011 10:26:17 AM
Subject: Re: 150 Congress Street

Hi Rich,

I just went thru the documents you e-mailed me and the floor plans you dropped off. These are my comments:

There are no heat detectors in the dwelling unit hall ways. Are these open to the dining rooms so the dining room heat detectors can cover the halls per code?

There are no heat detectors in the rooms directly above the front hall on floors 2, 3 and 4. Are these bathrooms less than 55 ft/sq?

I do not see any occupant notification inside the dwelling units. In particular I'm looking at a lack of audibles in the sleeping rooms.

The operations matrix is generic and does not speak to the operation of the heat detectors in the dwelling units.

No spec sheets for the wireless detectors.

The building will require a Knox Box. We are going to the 4100 series from now on with two exceptions:

Small residential buildings that are master keyed and with two complete sets of keys there is no more than 10 keys in the box and no access cards are required.

Large residential and other commercial buildings a secondary Knox Box that is only provided to give exterior access to a sprinkler room. Again the 3200 series can only accommodate 10 keys.

Where we will allow the 3200 series we are going to require it to be a hinged model to prevent jamming.

Thanks,
Ben

Lt. Benjamin Wallace Jr.
Fire Prevention Officer
Portland Fire Department
380 Congress Street
Portland, Maine 04101
(207)874-8400
wallaceb@portlandmaine.gov

>>> Rich Brobst <rich@protectionprofessionals.net> 10/18/2011 2:10 PM >>>

Good day:

Please note attachments. We will provide a more professional riser for the fire alarm system

but we desired getting the process began so we can start installing the system as soon as we can. I will deliver the floor plans tomorrow at our meeting. Please let me know if I am missing anything.

Thank you for your time;

*Rich Brobst, Jr
NICET III
Master Electrician
Protection Professionals
325 US Route One
Falmouth, Maine 04105
207-775-5755
Cell: 207-899-7761*

Protection Professionals

325 US Route 1
 Falmouth, ME 04105
 Ph 207-775-5755
 Fax 207-781-2064

Device List No. 3234

List Date
10/17/2011

Est To Name/Address
Rice Management 658 Congress Street Portland, ME 04102

Job Site
150 Congress Street Portland, Maine

CHANGING THIS DEVICE LIST DOES NOT ALTER THE ORIGINAL ESTIMATE
 Please copy to Portland office for approval.

Estimate No.

Item	Description	Qty To Order	Qty Ordered
V128FBP-PAK1	Vista- 128 FBP kit, includes V128FBP, 6160CR, 5140DLM, Red transformer enclosure requires 120VAC direct	1	
Bat 12-12	Battery	1	
5881ENHC	Wireless receiver for commercial burglary and 5800 devices	1	
IM-RJ31XSET	IM-RJ31XSET	2	
06-SSU00672	Fire Document box 12 inches wide X 13.1 inches high X 2.25 inches deep, CAT 30 keyed	1	
DK-DTK120HW	DITEK AC SURGE PROTECTION	1	
6160CR	Keypad Red	1	
SF-STI7510E	Keypad cover with lock set	1	
8085	Ademco cam lock assembly	2	
5140MPS-1	Manual Pull Station	14	
5817CB	Wireless Contact Module (use for fire contacts) for pulls	12	
BK-2WB	Smoke Detector w/ Base over FACP	1	
5808W3	Wireless smoke detector/heat detector with sounder (one per landing)	12	
BK-5601P	135°F Fixed Temp/Rate-of-Rise, Single-Circuit Mechanical Heat Detector (basement, hardwired to panel)	3	
5809	Wireless Heat Detector, 135 fixed temperature and rate of rise (apartments)	36	
AX-AL602ULADA	NAC power supply, 24 or 12 VDC, 6.5 amps, two Class A or four Class B at 2.5 amps/circuit, 1 amp Aux power	1	
Bat 12-7	12V 7AH Batteries	2	
500-636161	ZH-MC-R Horn/strobe, red, wall mount, Hi or Lo volume, 15cd, 30cd, 75cd, or 110cd	14	
AD-TG7FS	Fire Alarm Communicator, cell based	1	
Bat 12-7	12V 7AH Batteries	1	
D8004	UL TRANSFORMER KIT	1	
	State of Maine Sales Tax		

Ordered By: _____

Date: _____

Received By: _____

Date: _____

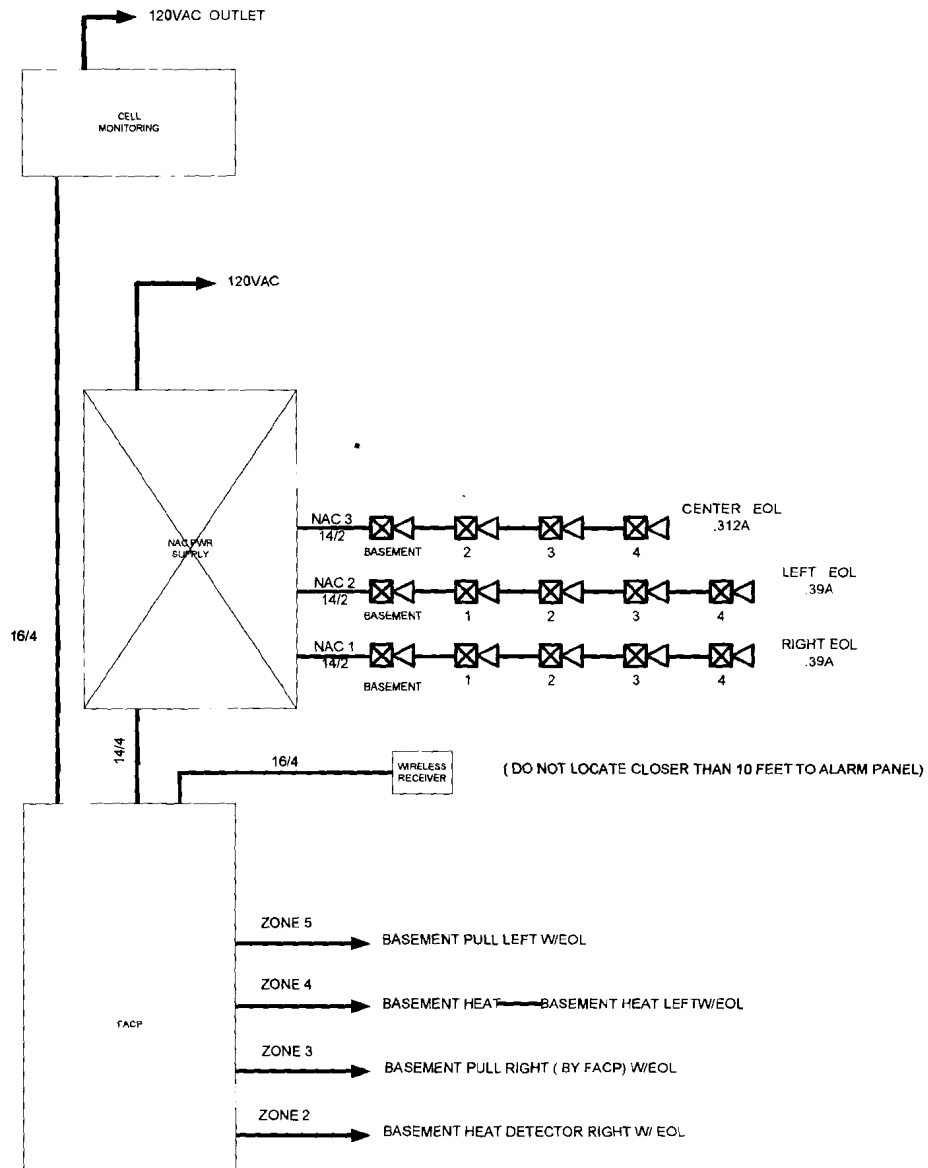

Sequence of Operations

	Audio/visual activation	Activate audible/visual signal at FACP & Annunciator	Device Description at FACP & Annunciator	Shutdown of HVAC equipment	Log event in system history	Activate Elevator Fire Hat	Activate Elevator primary or secondary control	Activate Elevator shunt trip	Silence of audible devices Including FACP & annunciator	Release door holders	Release locked doors	Event acknowledgement	Reset of all system functions and all visual devices	Remote transmission to Central Station A=alarm; T=trouble; S=Supervisory; L = log only	Remote indicator
Manual Pull Stations	X	X	X		X					X	X			A	
Smoke detectors common area	X	X	X		X					X	X			A	
Smoke detectors elevator lobbies	X	X	X		X	X	X			X	X			A	
Smoke Detectors elevator shaft/machine room	X	X	X		X	X	X			X	X			A	
Duct mounted Smoke Detectors		X	X	X	X									S	X
Heat Detectors common area/inside apartments	X	X	X		X					X	X			A	
Heat Detectors Elevator shaft/machine room	X	X	X		X	X		X		X	X			A	
Sprinkler flow or pressure switches	X	X	X		X					X	X			A	
Sprinkler Tamper, low temp, or low air		X	X		X									S	
Secondary fire panel such as kitchen hood	X	X	X		X					X	X			A	
FACP/annunciator silence button		X	X		X			X						L	
FACP/annunciator acknowledge button		X	X		X							X			
FACP/annunciator reset button		X	X		X								X	L	
Removal of any device		X	X		X									T	
Ground fault		X	X		X									T	
System wiring "open"		X	X		X									T	
AC Power loss		X	X		X									T	
Secondary power loss		X	X		X									T	
Telephone line loss		X	X		X									T	

Vista 128

Quantity	Part #	Description	Standby	Alarm	Total standby	Total alarm
1	V128	Fire Panel (maximum)	0.305	0.485	0.305	0.485
1	6160CR	Annunicator	0.150	0.150	0.150	0.150
	4208SN	Expander	0.001	0.033	0.000	0.000
			1.000	0.000	0.000	0.000
		Pull Station	0.000	0.000	0.000	0.000
1	2W	Smoke	0.000	0.130	0.000	0.130
	4W	Smoke	0.020	0.023	0.000	0.000
		heat	0.000	0.000	0.000	0.000
			0.001	0.001	0.000	0.000
		Motion	0.015	0.022	0.000	0.000
		Duct Detector	0.001	0.001	0.000	0.000
		Duct smoke	0.001	0.001	0.000	0.000
		Duct relay	0.001	0.001	0.000	0.000
		Duct Remote	0.001	0.001	0.000	0.000
		Remote light	0.001	0.001	0.000	0.000
			0.000	0.000	0.000	0.000
			0.000	0.000	0.000	0.000
		NAC power maximum (24V)	0.000	3.400	0.000	0.000
		NAC power maximum (12V)		2.300	0.000	0.000
					0.000	0.000
					0.000	0.000
		Miscellaneous			0.000	0.000
TOTAL			1.497	6.549	0.455	0.765

	Hours	Standby current		Total
	24	0.4551		10.921
Minutes		Alarm current		
5	0.08333333	0.7650		0.064
		Battery Capacity		
	10%	10.9850		12.083

Honeywell

VISTA-128FBP/V128FBP-24

COMMERCIAL PARTITIONED FIRE AND
BURGLARY ALARM CONTROL PANEL

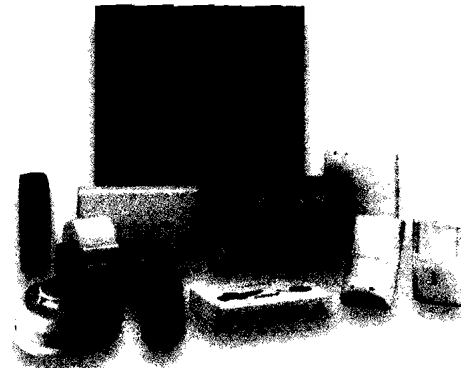

Now UL864 9th Edition Approved

Designed to integrate seamlessly with CCTV, access control and Honeywell's full range of fire and burglary components, the new VISTA-128FBP provides the ultimate protection of life and property. The UL Listed commercial fire and burglary control panel supports up to eight partitions and up to 128 zones/points using hardwired, wireless and V-Plex®

addressable technologies. A diverse line of Honeywell initiating devices, notification circuits, communication devices, keypads, RF receivers and relays are also supported. The VISTA-128FBP has been designed to mount quickly and easily in an attack resistant cabinet, and is available in 12V and 24V models.

FEATURES

- Eight hardwired zones standard, expandable to 120 V-Plex addressable points/zones or 128 wireless points/zones
- Can control eight separate areas independently (8 partitions)
- Supports commercial wireless fire and burglary devices
- Stores up to 512 events
- Accommodates 150 user codes and up to 250 access card holders using VistaKey
- Supports V-Plex addressable VistaKey access control (1 to 8 doors)
- Two on-board notification (bell) circuits delivering 2.3A @ 12V or 3.4A @ 24V
- Automatic smoke detector sensitivity maintenance testing
- Four-wire smoke reset using onboard J2 output trigger
- Supports Dynamic Signaling for AlarmNet Communicators
- Supports Remote Control via the Internet*
- Supports Internet Alarm Reporting*
- Supports Graphical User Interface Consoles
- Listed to UL864 9th Edition
- Upload/download via Ethernet*
- Carbon monoxide (CO) zone support

* *When used with AlarmNet devices.*

VISTA-128FBP/V128FBP-24

COMMERCIAL PARTITIONED FIRE AND BURGLARY ALARM CONTROL PANEL

Honeywell

ADDITIONAL FEATURES

- Notification Appliance Circuits (two):
 - Programmable
 - Temporal code compliant
 - Individually silenceable
- Programmable on-board auxiliary relay
- False alarm reduction features:
 - Exit error logic
 - Exit delay reset
 - Cross zoning
 - Call waiting defeat
 - Recent close report
- Supports commercial hardwired, addressable V-Plex polling loop and wireless zones
- Hardwired zones
 - Provides eight style B hardwired zones
 - EOLR supervised for Fire and UL burglary installations
 - Supports N.O. or N.C. sensors
 - Individually assignable to any eight partitions
 - Up to 32 two-wire smoke detectors each on zone one and two (64 total)
- Up to 50 two-wire glassbreak detectors on zone eight
- Patented addressable V-Plex polling loop technology
 - Supports 120 two-wire zones points
 - Global polling technology for faster processing
 - Supervised by panel
 - Zones individually assignable to partitions, notification circuit (bell) output or auxiliary relay
 - 4,000 ft. capability without the use of shielded cable
 - Extender/Isolation bus modules
 - Eight zone – Class A and B expander module
 - Eight zone – Class B expander module
 - One zone supervised contact monitor module
- UL Listed wireless expansion
 - Supports up to 128 wireless zones/points
- Supervised by control for check-in signals
- Tamper protection for transmitters
- Individually assignable up to eight partitions
- Supports commercial wireless smoke detectors
- Access Control integration
 - Full integration with PassPoint Access Control System Complete Gateway interface of VISTA and access functions
- Up to eight doors using VistaKey V-Plex Access Control
- Event reporting
- Local printer of access or VISTA related events
- Communication
 - Phone mapping by zone response type
 - Panel operation during download

SPECIFICATIONS

Applications

The VISTA-128FBP control is well suited for a variety of applications as an integrated fire and burglary control. A diverse line of Honeywell initiating devices supports this extremely powerful control. Some of the applications supported are: medical and professional buildings, churches or synagogues, office buildings, schools, strip malls, larger residences and factory or warehouse environments.

Electrical

- Primary power: 18VAC @ 72VA
Honeywell No. 1451
- Control panel quiescent current draw: 300mA
- Backup battery:
 - 12VDC, 12AH min to 34.4AH max
 - Lead acid battery (gel type)
- Alarm power: 12VDC, 1.7A max for each notification (bell) circuit output
Total 2.3A @ 12V
- Aux. standby pwr: 12VDC, 1A max
- Total power: 2.3A at 12VDC, 3.4A at 24VDC from all sources
- Standby time: 24 hours with 1A standby load using 34.4AH battery

- Fusing: Battery input, aux. and notification (bell) circuit outputs are protected using PTC circuit protectors. All outputs are power limited.
- Optional 24-volt power supply, PS 24 supplies two 24 VFW, 1.7A full wave rectified, unfiltered outputs

Main Dialer

- Line seize: Double Pole
- Ringer equiv.: 0.7B
- Formats: ADEMCO Low Speed, ADEMCO 4+2 Express, ADEMCO High Speed, ADEMCO Contact ID, SESCOA and Radionics
- Dual phone line capability (using 5140DLM module)

Cabinet dimensions

- 18" H x 14.5" W x 4.3" D

Environmental

- Storage temp: 14° F to 158° F
(-10° C to 70° C)
- Operating temp: 32° F to 122° F
(0° C to 50° C)
- Humidity: 85% RH

- EMI: Meets or exceeds the following requirements:
 - FCC Part 15, Class B Device
 - FCC Part 68
 - IEC EMC Directive

Agency Listings

- UL609 Grade A Local Mercantile Premises and Mercantile Safe and Vault
- UL611/1610 Grades A, AA, Central Station
- UL365 Grades A, AA Police Connect
- UL864/NFPA72 Local, Central Station and Remote Station
- UL985
- Factory Mutual
- California State Fire Marshal
- MEA
- CAN/ULC S304 – Central and Monitoring Station Burglar Alarm Unit
- CAN/ULC S527 – Central Unit for Fire Alarm Systems
- CAN/ULC S303 – Local Burglar Alarm Unit
- CAN/ULC S525 – Audible Signal Appliances

VISTA-128FBP/V128FBP-24

COMMERCIAL PARTITIONED FIRE AND BURGLARY ALARM CONTROL PANEL

COMPATIBLE DEVICES

Auxiliary Devices

- 6160CR-2 – Red Alpha Keypad
- 4204 – Relay Module, four form C contacts
- 4204CF – Two supervised output circuits
- 5881 Series RF receiver
- 5883H RF receiver
- 6220S – System printer used with 4100SM serial module
- 6160CR-2 – Red Fire Keypad
- 6160 – Burglary Keypad

Two-Wire Smoke Detectors

Conventional

- System Sensor
- ESL
- DSC

Horn/Strobes

- System Sensor
- Wheelock
- Gentex

Manual Pull Stations

- 5140MPS-1
- 5140MPS-2

V-Plex (Addressable) Devices

- 4208U Loop Expansion Module – eight zones
- 4101SN Single Relay/Zone Module

- 4208SNF Class A/B Expander Module
- 4190SN Remote Point Module – two zones
- 4193SN Two-Zone Serial Interface Module
- VSI Module
- 4293SN One-Zone Serial Interface Module

V-Plex Extender/Isolation Modules

- 4297 Extender/Isolator Module
- VSI Isolator Module

V-Plex Smoke Detectors:

- 5193SD
- 5193SDT

V-Plex Passive Infrared Detectors

- 998MX
- IS2500SN
- DT7500SN

V-Plex (Addressable) Contacts

- 4939SN-WH
- 4944SN-WH
- 4959SN

V-Plex Glassbreak Detectors

- FG1625SN

Optional 24V Power Supply

- PS24 – 24V power supply – 3.4A

Commercial Wireless Devices

- 5808W3 – Photoelectric Smoke/Heat Detector
- 5806W3 – Photoelectric Smoke Detector
- 5809 – Wireless Heat Detector
- 5817CB – Wireless Commercial Transmitter
- 5869 – Hold-Up Transmitter
- 5881ENHC – RF Receiver
- 5883H – RF Receiver

Access Control

- VistaKey V-Plex (addressable) Access Control
- VistaKey-SK Starter Kit
- VistaKey-EX Expansion Kit

Alarm Communications

- 7845i-ENT – Internet/Intranet Communicator
- 7845GSM – Digital Cellular Communicator
- 7845i-GSM – Internet and Digital Cellular Communicator
- GSMCF/iGSMCF – Commercial Fire Communication Kits (when available)

Product specifications subject to change.

ORDERING

V128FBP-8

Commercial Fire and Partitioned Burglary Alarm Control Panel 12V Model

V128FBP-24

Commercial Fire and Partitioned Burglary Alarm Control Panel 24V Model

For more information: www.honeywell.com/security/hsc

Automation and Control Solutions

Honeywell Security & Communications
2 Corporate Center Dr. Suite 100
Melville, NY 11747
1.800.467.5875
www.honeywell.com

Honeywell

L/VSTA128FBPD/D
September 2009
© 2009 Honeywell International Inc.

TELGUARD

TG-7FS

COMMERCIAL FIRE

PRODUCT FEATURES

Meets UL 864 requirements for sole, primary or backup path communications.

Supports virtually all alarm formats for universal panel compatibility.

Connects to your central station's PSTN or IP receivers.

Saves your customers money by replacing landline costs.

The Telguard TG-7FS is the ideal cellular alarm communications solution for commercial fire systems. The TG-7FS transmits alarm signals from the fire panel over the digital cellular network to the designated monitoring station.

Compliant with the 2010 Edition of NFPA 72, the TG-7FS can serve as the sole communications path for the fire alarm system, replacing all of the landlines currently dedicated to the master control unit. On average, cellular monitoring costs the end user significantly less than a dedicated landline. For each landline replaced with a TG-7FS, the monthly communications bill decreases.

By being able to signal failures to the central station within five minutes of an outage, the TG-7FS can be installed as the sole path for commercial fire installations. For existing installations, all landlines can be swapped for a single TG-7FS because of the new five minute supervision mode.

The TG-7FS can also be installed as a backup path, and upgraded to sole path at a later date.

Telguard Online

Telguard makes adopting cellular easy with a secure internet portal. The straightforward web interface allows security dealers and central stations to quickly and efficiently access Telguard based services 24/7. This advanced tool has multi-level user authorization and provides total account management of UL Listed Telguard cellular alarm communicators.

Telguard Cellular Service

Telguard Cellular Service provides nationwide digital cellular network coverage for all Telguard units. Telguard's Communication Center is UL listed and provides seamless connectivity between the alarm panel, the Telguard family of products and the central station. Telguard Technical Support provides a single point of contact for both cellular service and Telguard product questions.

Advanced Reliability

- Available relay output for tripping the alarm control panel when a trouble condition occurs.
- Automatic self-tests with central station notification ensure the cellular system is operating.
- 128 bit AES (Advanced Encryption Standard) alarm signals ensure authentication and security.
- Features SMS backup to reduce false alarms, providing supervision using SMS if CPRS fails.

TG-7FS

TELGUARD

Power

- Transmit power: 1.0W-2.0W (maximum allowable).
- Power Consumption:
60mA (Standby)
250mA (Transmission).
- Transformer: 12VAC, 800mA
UL listed plug-in.

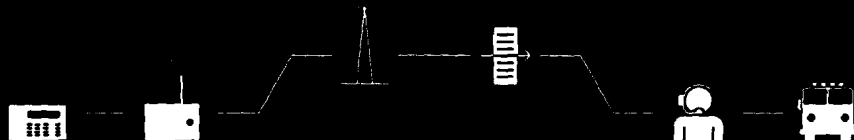

Radio Transceiver

- Dual band cellular and PCS.
- GSM 850MHz: Class 4 (2 watt).
- GSM 1900MHz: Class 1 (1 watt).
- Antenna: 9" dipole with 2dBi gain,
12 ft of cable and universal mounting
bracket.
- FCC part 15, 22, 24 and 68 compliant.

Physical Details

- TG-7FS: 7.5" H x 11.5" W x 3.5" D
- Shipping Weight: 8lbs
- Operating Environment:
0°C to +50°C, up to 95% humidity
(non-condensing).

Standard Features

- Full data reporting.
- Automatic self-test (5 min. & daily).
- Power supply with battery harness.
- Locking, red metal enclosure.
- Two programmable supervisory
trip outputs.
- Alarm format support for SIA2,
Contact ID, pulse (5x1, 4x2),
modem IIc, & IIIa2, DMP.
- Telephone line monitor built-in,
with Standard Line Security.

Telguard technology allows full data reporting for unlimited point-to-point signal details and maximum transmitting power for superior in-building penetration.

Telguard products are easy to install, economical, and UL Listed.

Accessories

- ACD 12, ACD 35, ACD 50, ACD 100:
12/35/50/100 feet of low loss, high performance cable.
- E-GD-0: High gain directional antenna.
- EX-D-0: External antenna.

UL Listings

Commercial Fire

904 • Central units &
accessories for fire
alarm systems

Commercial Burglary

903 • Police Station
central units based on
alarm units and
expansions

Residential

905 • Single and multi
dwelling units for
alarm systems
1073 • Single and multi
dwelling units

1070 • Central Station
based alarm units





AL602ULADA, AL802ULADA, AL1002ULADA NAC Power Extenders

Rev. AL602/802/1002ULADA- A05I

Overview

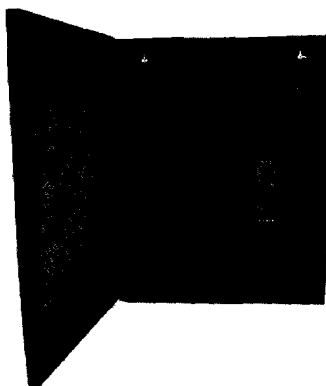

The AL602ULADA, AL802ULADA and AL1002ULADA are extremely cost effective voltage regulated remote NAC Power Extenders. They may be connected to any 12 or 24 volt Fire Alarm Control Panel (FACP). Primary applications include Notification Appliance Circuit (NAC) expansion (supports ADA requirements) and will provide auxiliary power to support system accessories.

AL602ULADA

- 24VDC or 12VDC rated @ 6.5 amp max.
- Two (2) Class A or four (4) Class B outputs.

AL602ULADAJ

- Larger enclosure.

AL802ULADA

- 24VDC or 12VDC rated @ 8 amp max.
- Two (2) Class A or four (4) Class B outputs.

AL802ULADAJ

- Larger enclosure.

AL1002ULADA

- 24VDC rated @ 10 amp max.
- Two (2) Class A or four (4) Class B outputs.

AL1002ULADAJ

- Larger enclosure.

Specifications

- Two (2) Class A or two (2) Class B FACP inputs.
- Two (2) NC dry contact trigger inputs (AL802ULADA and AL1002ULADA only)
- Two (2) Class A or four (4) Class B indicating circuits.
- Two (2) Class B outputs may be paralleled for more power on an indicating circuit.
- One (1) Aux. Power Output @ 1 amp supply current (w/battery back up).
- Signal Circuit Trouble Memory - facilitates quickly locating intermittent system trouble and eliminates costly and unnecessary service calls. LED's indicate a prior fault (short, open, ground) has occurred on one or more signaling circuit outputs.
- 2-wire Horn/Strobe Sync mode allows audible notification appliances (Horns) to be silenced while visual notification appliances (Strobes) continue to operate.
- Horn/Strobe sync protocols include: Gentex®, System Sensor®, Faraday, Amseco.
- Temporal Code 3 Mode.
- Steady Mode.
- Input to Output Follower Mode (maintains synchronization of notification appliance circuits).
- March Time.
- Compatible with 24VDC or 12VDC fire panels.
- Common trouble inputs and outputs.
- Ground fault detection.
- Input 115VAC.
- AC fail supervision (form "C" contacts).
- Low battery supervision (form "C" contacts).
- Battery presence supervision (form "C" contacts).
- Power supply, logic board, red enclosure, cam lock, transformer & battery leads.
- Enclosure:
 - Combination knockouts re 1/2" and 3/4"
 - Accommodates up to two (2) 12VDC/12AH batteries.

Agency Approvals



UL Listed Control Units and Accessories for Fire Alarm Systems (UL 864),
UL Listed Standard for Safety for Fire Protective Signaling Systems (UL 1481).



California State Fire Marshal Approved.



MEANYS Department of Buildings Approved.



Factory Mutual Approved.

Enclosure Dimensions

AL602ULADA, AL802ULADA and AL1002ULADA: 15.5"H x 12"W x 4.5"D

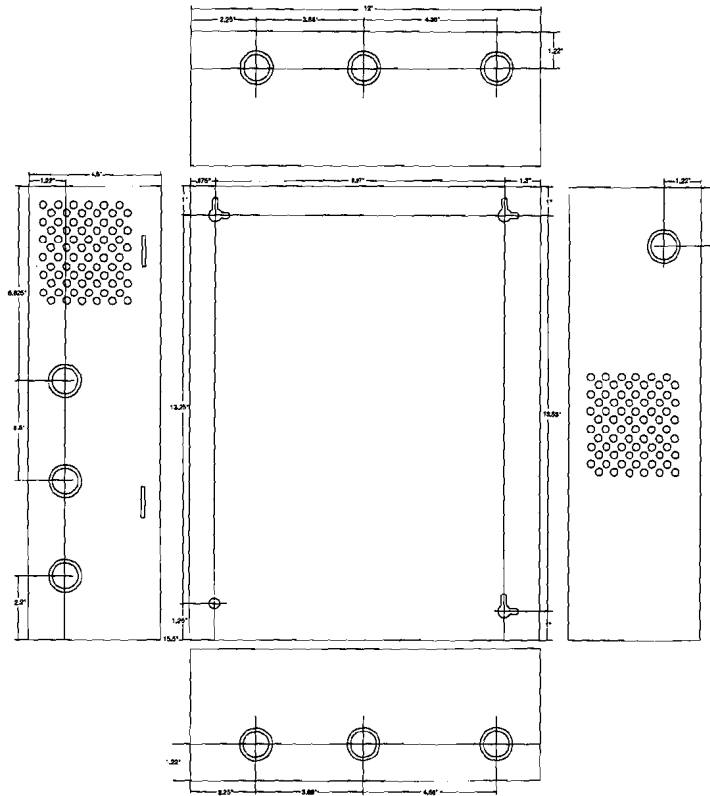

AL602ULADAJ, AL802ULADAJ and AL1002ULADAJ: 18"H x 14.5"W x 4.625"D

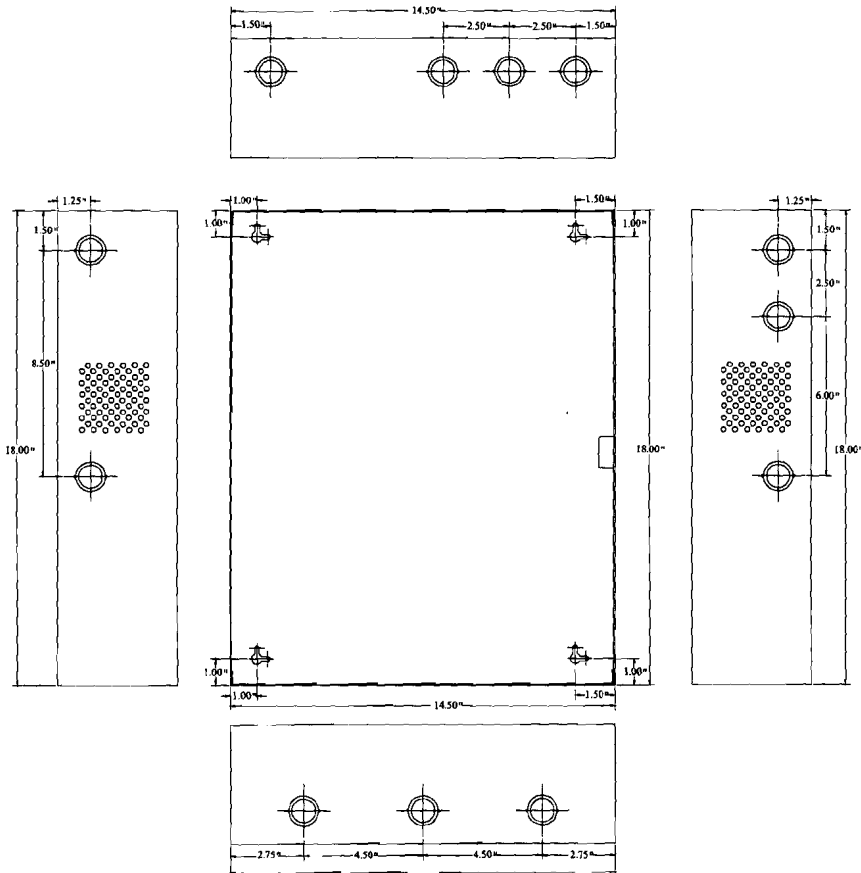

Honeywell

5809

WIRELESS HEAT DETECTOR

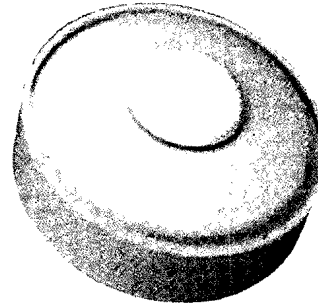

Honeywell's 5809 wireless fixed heat and rate-of-rise temperature sensor offers expanded fire detection and installation flexibility. It is ideal for hard to wire locations and applications that require more than smoke detection. With no wires to run, the 5809 is fast and easy to install. The 5809 combines both rate-of-rise and fixed temperature sensors. Fires typically cause a rapid rise in temperature in the

surrounding area. The 5809's rate-of-rise thermostat senses the rise in temperature and signals an alarm if the increase is 15° or more per minute. A built-in fixed temperature sensor will also signal an alarm if the environmental temperature rises above 135°F. The 5809 is UL Listed (UL521) and CSFM approved for commercial and residential applications.

FEATURES

- Contains a built-in transmitter which can send alarm, supervisory and battery condition messages to the system's receiver/control unit
- Powered by a three-volt lithium battery. If the battery voltage gets too low, the 5809 sends a low battery signal to the control panel
- Features a tamper switch, which causes a trouble signal to be sent to the control if the unit is removed from the mounting base
- UL Listed for Commercial (when using 5881EH Receiver) or Residential applications

5809

WIRELESS HEAT DETECTOR

SPECIFICATIONS:

• **Power:**

- 3V lithium battery (Duracell DL123A, Panasonic CR123A, Sanyo CR123A, Varta CR123A)
- Operating temperature: 40° to 140°F (6° to 60°C)
- Rate-of-rise temperature: 15°F (8°C) increase per minute (NOTE: Rate-of-rise sensor does not operate above 38°C)

- Fixed temperature: 135°F (57°C)
- Maximum spacing: 50 ft x 50 ft UL, 30 ft x 30 ft FM (refer to National Fire Alarm Code Standard NFPA 72 for application requirements)
- Dimensions: 4.4" diameter/2.2" deep

• **Agency Listings:**

- UL 521 Listed for Commercial (when using 5881EH Receiver) or

Residential applications

• **Wireless Transmission Path Test:**

- A good RF transmission path must be established from the proposed mounting location before permanently installing the detector. To determine that there is a good signal reception from the proposed location, perform the test procedure described in the installation instructions procedure.

MOUNTING THE DETECTOR:

- You can mount the 5809 on a wall or ceiling within the protection area:
- Wall mounting: Mount the detector 4" - 6" from the ceiling
- Ceiling mounting: Mount the detector at least 4" from any wall. Make sure the normal ceiling temperature will not exceed 100°F (37.8° C).

- Refer to NFPA Standard 72 for detector spacing and other requirements. Maximum spacing for UL installations is 50' x 50'
- Avoid mounting the detector near heat generating devices (e.g. ovens, heat vents, furnaces, boilers)
- IMPORTANT: Heat detectors should

be used for property protection. Reliance should not be placed solely on heat detectors for life safety. When life safety is involved, smoke detectors MUST also be used. Detectors must not be painted.

TESTING THE DETECTOR:

The test procedure should be performed to determine a good RF transmission path and again after installation is completed.

CAUTION: The fixed temperature sensor is intended for one-time use. Prolonged heat during testing can damage the unit. If used carefully following the instructions described below, the heat from a portable hair dryer can be used to test the unit. If the round disk on top of the detector detaches, the detector must be replaced.

- Activate the control panel's test mode

- Use either method (a) or (b) or activate the detector

- (a) Press and release the activation button on the PC board assembly OR
- (b) Holding a portable hair dryer about 12 to 18 inches away from the detector, turn the dryer on and aim the warm air at the side of the detector.

CAUTION: Aiming the dryer directly at the round disk on the detector can damage the unit to be replaced.

- The system's keypad should beep and the detector's ID should be displayed

- Exit the control's test mode
FCC ID: CFS 8DL 5809

This device complies with part 15 of FCC rules.

Operation is subject to the following conditions:

- (1) This device may not cause harmful interference, and (2) this device must accept any interference received, including interference that may cause undesired operation.

ORDERING

5809 Heat Detector

Honeywell Security & Custom Electronics

Honeywell
2 Corporate Center Drive Suite 100
P.O. 9040
Melville, NY 11747
www.honeywell.com

Honeywell



5140MPS-1 / 5140MPS-2 Manual Pull Stations

PRIMARY FEATURES

- ADA COMPLIANT
- KEY TEST OR ALLEN RESET
- KEYED TO ADEMCO CONTROLS
- STYLIZED HIGH TECH DESIGN
- ALUMINUM DIE CAST HOUSING
- TERMINAL BLOCK OR WIRE LEADS
- GOLD CONTACTS
- UL LISTED

■ GENERAL DESCRIPTION

Ademco's manual fire alarm stations are designed to be non-code single action devices for use in UL listed fire alarm applications. The attractive die-cast aluminum-alloy housing meets ADA pull requirements and has been tested at Underwriter's Laboratory.

For ADA compliance, manual stations must be mounted less than 48" above the floor for front wheelchair access and less than 54" above the floor for side wheelchair access.

A key reset feature on the 5140MPS-1 is designed for positive authorized resetting action. The key is designed to operate and match Ademco controls. The 5140MPS-1 utilizes a terminal block for secure terminations. The 5140MPS-2 is furnished with an Allen hex fitting and is equipped with wire leads.

Two alarm deterrent break tubes are supplied with each manual station; one tube is visible from the front, and the spare is stored in a compartment within the unit.

■ OPERATION

Pulling the handle down causes the manual stations to latch in the down position and to close the normally open switch. The handle is restored manually by using the key to unlock the station and pivot the station forward for resetting the pull handle to its normal position. The crush tube is then inserted in the cavity and the station assembly is then locked in the normal upright position.

■ CONSTRUCTION

The 5140MPS-1 and 5140MPS-2 manual stations are constructed of a durable die-cast aluminum-alloy and

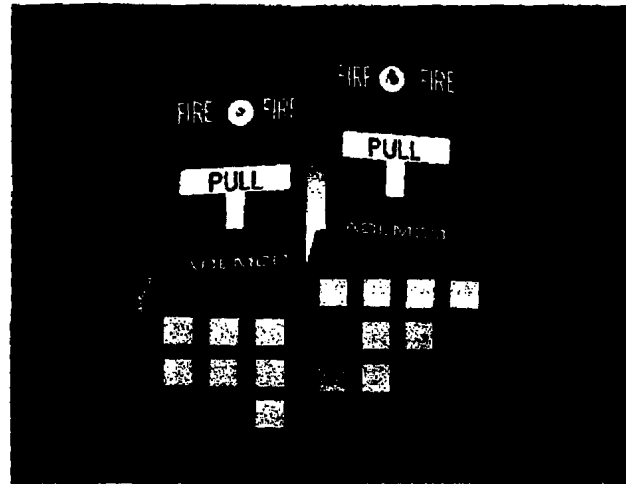

provide a neat and distinctive appearance. The housing is finished in red with white raised lettering and the "T-bar" handle is white with raised red lettering for enhanced visibility. The units are adaptable to both surface and semi-flush mounting configurations.

■ MOUNTING

SEMI-FLUSH MOUNT

Most semi-flush mount installations can be attached to a standard single-gang switch box using two 6-32 screws inserted through the slots that are centered on the unit's metal mounting plate.

SURFACE MOUNT

Use Ademco Backbox model number 5140MPS-BB for surface mount installations. The Backbox has four pre-drilled mounting holes of 0.187 inch diameter and conduit knockouts. Secure the Backbox to a wall with screws of size 8 or smaller. After the Backbox is in place, attach the conduit.

The housing is locked by using a key or Allen wrench lock. Unlock the housing by turning the key clockwise and swinging down the front of the housing to make the sheet metal mounting plate accessible. Mount the metal plate to the Backbox using the four 1/4" long, 8-32 screws (supplied).

■ DIMENSIONS

4.75" H x 3.12" W x 2" D

ADEMCO

The Technology Leader

■ ORDERING INFORMATION

5140MPS-1: Manual Station
Key Reset Test
and Terminal Block

5140MPS-2: Manual Station
Hex Allen Reset
Test and Wire Leads

5140MPS-BB: Surface Backbox

■ WIRING DIAGRAM

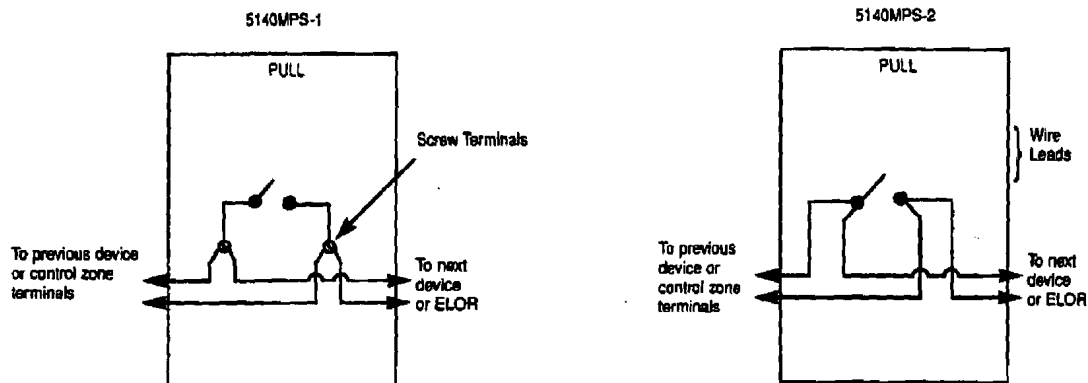

ARCHITECTURAL/ENGINEERING SPECIFICATIONS

Manual Fire Alarm Station Model 5140MPS-1 (5140MPS-2) shall be non-coded and include a break-type tube operated test-reset lock allowing testing with a key (Allen wrench). They shall be designed so that normal operation cannot be restored after an actual Fire Emergency Operation except by use of a key (Allen wrench). The key shall fit all standard Ademco controls.

An operated station shall automatically condition itself so as to be visually detected, as operated, at a mini-

imum distance of one hundred feet, front or side. Manual Stations shall be constructed of die cast aluminum alloy with clearly visible operating instructions provided on the cover. The word FIRE shall appear on the front of the stations in raised letters. Stations shall be suitable for surface mounting on matching Backbox, or semi-flush mounting on a standard single-gang box. Manual Stations shall be Underwriter's Laboratories Listed.

ADEMCO

The Technology Leader

5817CB

WIRELESS COMMERCIAL TRANSMITTER

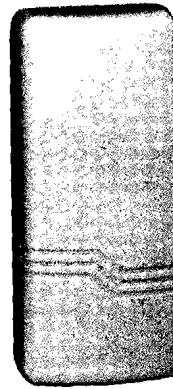

The 5817CB is a universal contact-monitoring transmitter that can be used with household and commercial fire and burglary-initiating devices such as door/window contacts, motion and glassbreak detectors, sprinkler water flow

switches, tamper switches, post indicator valves, manual pull stations and remote duct detectors. Upon activation, it emits an RF signal to a control panel, sending a burglary or fire alarm to a central station.

FEATURES

- The 5817CB has three unique input loops (zones).
- The first loop (primary loop) is supervised and typically used for high-priority alarm reporting such as commercial fire or burglary.
- The second loop is the built-in, normally closed reed switch used in conjunction with magnet.
- The third loop is another normally closed household burglary loop. All three loops may be used.
- A fourth (automatically enrolled) loop contains two tamper switches to protect the 5817CB.

MOUNTING

1. Remove the transmitter cover by inserting the flat blade of a small screwdriver into the pry-off slot at the bottom end of the unit (on the right side closest to the cover's decorative ribs and twisting).

2. Disengage the supplied mounting plate from the unit by inserting the blade of a small screwdriver into the mounting plate release hole (see Diagram 2) and pushing the locking tab out (see Diagram 1). Slide the mounting plate downward along the case back.

Note: For this application, the alignment guide strip along one edge of the mounting plate serves no function and may be broken away, if desired.

3. If concealed wiring is to be used, feed the wires through the concealed wiring entry hole on one corner of the plate (surface wiring is mentioned in step 5 below).

4. Install the mounting plate, with its caseholding posts pointing up, in the location selected as described in the

installation instructions. Use the two flat-head screws supplied. Note: To ensure proper operation of the unit's back tamper (when it is separated from the mounting plate), the screws must be anchored to a wall stud or other solid wood material.

5. Set the DIP switch (after the control panel has enrolled the transmitter's input ID's) for the desired primary loop characteristics, as described in the table on the following page.

5817CB

WIRELESS COMMERCIAL TRANSMITTER

Primary Loop Options Table				
Switch Setting	DIP Switch Position			
	1	2	3	4
On	Repeating transmission (every 4 sec.) upon primary loop fault use for high priority alarm, such as fire.	Switch must always be in the on position	Switch must always be in the on position	Switch must always be in the off position
Off	Single transmission per primary loop change-of-state			

Notes: a. In order for the control panel to enroll the transmitter, the DIP switches must be Set to OFF-ON-ON-OFF (see Diagram 2).
 b. The auxiliary loops are not affected by the DIP switch settings.

Wiring Connections

Connect the loop wiring to the unit's terminals before installing the battery (see Diagram 2).

Notes: a. Primary loop 1 is a supervised loop and must have an end-of-line (EOL) resistor (470K ohms, supplied) placed across the sensor. Additionally, for primary loop 1, a contact device may not be installed more than 20 feet from the transmitter.

b. If loop 2 is not going to be used, the magnet is not necessary.

c. If loop 3 is not going to be used, no connection is needed across its terminals. For UL household burglary and fire installations, the loop 3 contact device (if used) may not be more than 3 feet from the transmitter.

SPECIFICATIONS:

• Dimensions:

- 1-9/16"W x 3-1/2"H x 1-3/16"D
(40mm x 89mm x 30mm)
- Battery 3v Lithium
(see BATTERY INSTALLATION AND REPLACEMENT).

• UL Listings:

- Commercial Fire UL864
- Household Fire UL985
- Household Burg UL1023
- Commercial Burg UL365, UL609, UL1076, UL1610

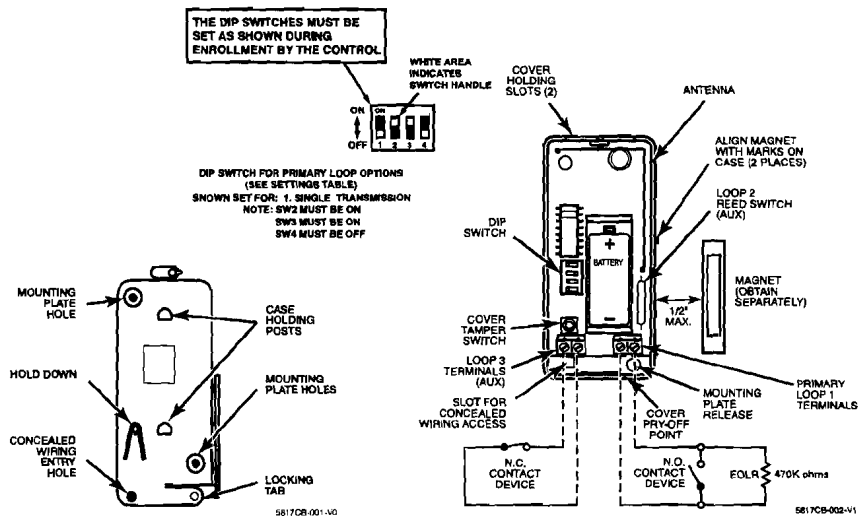

Note: For UL commercial and household fire installations, only one initiating device may be connected to this transmitter. For UL commercial burglary installations, multiple initiating devices may be used as long as the devices all service the same function such as door/window contacts, motion or glassbreak detectors. All initiating devices must be located within the same room.

ORDERING

5817CB

Wireless Commercial/Household Transmitter

Honeywell Security & Custom Electronics

Honeywell
 2 Corporate Center Drive Suite 100
 P.O. Box 9040
 Melville, NY 11747
 www.honeywell.com

Honeywell

L/5817CB/D
 August 2007
 © 2007 Honeywell International Inc.

STI Polycarbonate Enclosure

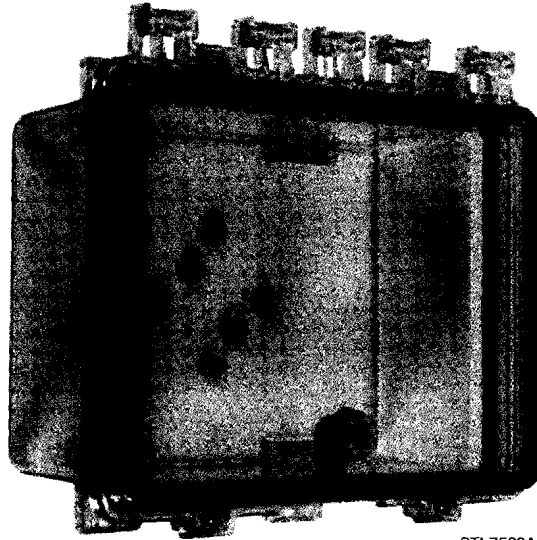

STI-7500A

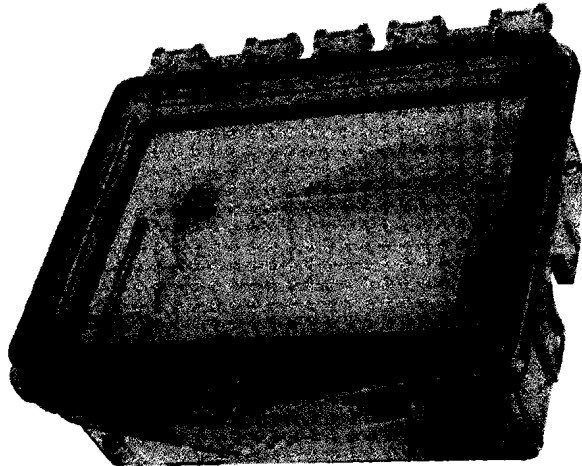

STI-7511D

PRODUCT OVERVIEW

Multipurpose lockable enclosure for a wide range of larger size devices, components and instruments, such as keypads, annunciators and automated external defibrillators (AEDs) which require protection from vandalism, accidental damage, as well as the elements, such as dirt and grime. Spacers, integrated hinge and covers are formed from super tough polycarbonate material. The polycarbonate enclosures are backed by a lifetime guarantee against breakage and damage in normal use. STI enclosure is lockable with either a key or thumb lock.

FEATURES

- Protection for large units against physical damage, grime and severe environments.
- Key or thumb lock available.
- Mounting hardware and gaskets are included.
- Fast and easy installation.
- Can be used over volume or lighting controls.
- 94V-2 flammability rating.
- Cover, integrated hinge and spacers are formed from super tough polycarbonate material.
- Each protected unit can be clearly seen and quickly identified.
- Typical working properties of polycarbonate are -40° to 250°F (-40° to 121°C).
- Lifetime guarantee against breakage of polycarbonate in normal use.

STI Polycarbonate Enclosure

Dimensions and Technical Information

MODELS AVAILABLE

- STI-7500 Cover with key lock and backbox
- STI-7501 Cover with thumb lock and backbox
- STI-7510 Cover with exterior key lock and backbox
- STI-7511 Cover with exterior thumb lock and backbox

NOTE: Select backbox from below

Accessories

- 18021 NEMA 4X 3/4" rigid conduit hub for "A" backbox
- 18054 Replacement key #CH751
- SUB-318 Adapter plate used for mounting "A", "B" or "F" backbox to pedestal
- SUB-6297B20 3/4" conduit hub for "B", "C" and "F" backboxes
- STI-1283 Backplate

BACKBOX DESCRIPTION

- A Enclosed deep backbox
- B Enclosed backbox with double-gang electrical box
- C Open backbox for flush mount applications
- D Open conduit backbox, surface mount applications
- E Open backbox for flush mount applications
- F Enclosed backbox

APPROVALS & WARRANTY

TESTING

The STI-7500 series only has been tested and approved or listed by:
 · UL/cUL Listed No. S7255

WARRANTY

Lifetime guarantee against breakage of polycarbonate in normal use.

NOTICE

STI recommends replacement of gaskets every five years for outdoor applications.

	STI-7500/7501						STI-7510/7511		
B	G	H	J	K	L	M	N	P	
A	8.48	5.40	4.15	6.48	3.40	8.48	6.48	4.59	
C	8.50	5.40	1.30	5.50	0.55	8.50	5.50	1.74	
K	7.81	4.80	2.51	6.25	1.75	7.81	5.25	2.95	
B	7.73	5.40	3.54	5.70	2.79	7.73	5.70	3.98	
O	7.70	5.40	1.76	5.71	1.01	7.70	5.71	2.20	
X	8.30	4.80	2.35	5.63	1.60	8.30	5.63	2.79	

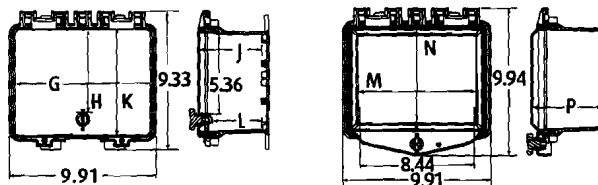

NOTE: Below pictures illustrate backbox differences.

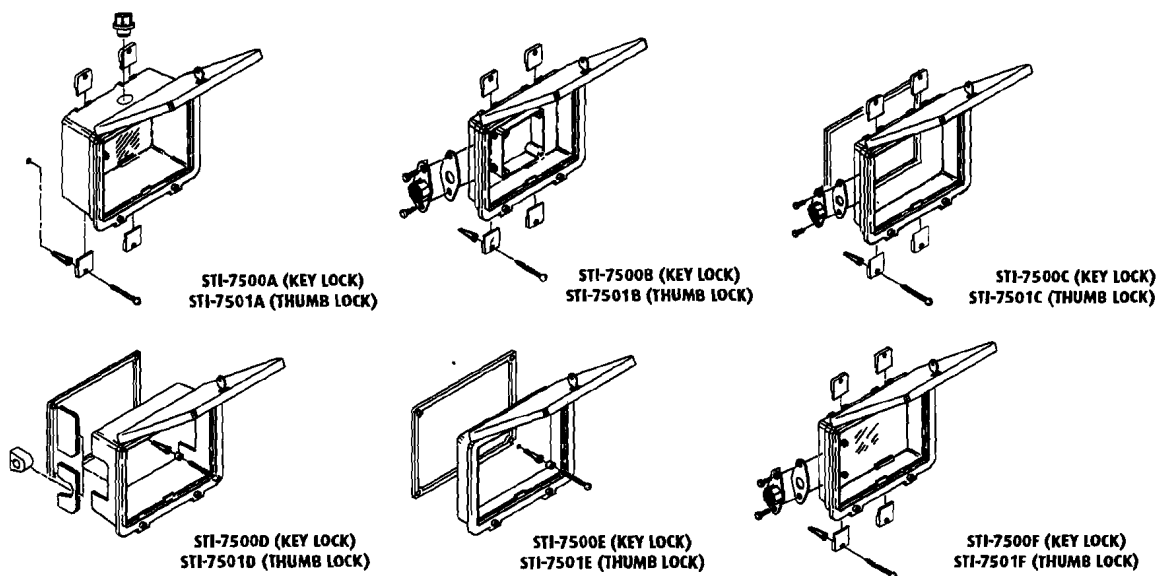

Safety Technology
International, Inc.

2300 Airport Road
Waterford, Michigan
48327, USA

Tel: 248-673-9598
Fax: 248-673-1246
Toll-free: 1-800-259-1774
info@sti-usa.com
www.sti-usa.com

Unit 496 Pipps Road
Park Farm Industrial Estate
Bosfield, Worcester
WR3 195, England

Tel: 44 (0) 1527 520 999
Fax: 44 (0) 1527 501 999
E-mail: info@sti-uk.com
www.sti-uk.com

Z Strobes, Horns, Horn/Strobes

Features

- UL listed. ULC, CSFM, and FM pending.
- ADA/NFPA compliant
- EZ Mount design, with separate base plate, provides ability to pre-wire the base and test the circuit wiring before the walls are covered
- The base plate is protected by a disposable cover and the appliances can quickly snap onto the base after the walls are painted.
- EZ Mount Universal Mounting Plate (ZBB) – uses single plate for ceiling and wall mount installations
- Wall Mount models feature field selectable candela settings of 15/30/75/110cd and 135/185cd
- Ceiling Mount models feature field selectable candela settings of 15/30/75/95cd and 115/177cd
- Strobes can be synchronized using the Siemens 5406B sync modules, MPC-6000 panel, MPC-7000 panel, or RSE-300 power supply with built-in sync protocol
- "Special Applications" listed with Siemens panels
- Strobes produce 1 flash per second
- Selectable Continuous Horn or Temporal (Code-3) Tones with selectable 90 or 95 dBA setting (ZH model)

Description

The Siemens Series Z notification appliances feature an easy snap on base that is designed to simplify the installation and testing of horns, strobes, and horn/strobes. The separate Series Z snap on base can be pre-wired so circuit wiring can be fully tested before the appliance is installed and before the walls are covered. Once all surrounding work is complete, the appliance can be simply installed by snapping it on the base. Shorting contacts in the base, which provide continuity for circuit testing, are permanently opened when the appliance is installed so any subsequent removal of the appliance will indicate a trouble condition on that circuit at the control panel when circuit supervision is enabled. The same base is used for all Series Z horns, strobes and horn/strobes to provide consistent installation and easy replacement of appliances if required. A locking screw is also included for the appliance to provide extra secure installation.

The Siemens Series Z appliances incorporate the same dependable circuitry and high efficiency optics that are used in Siemens ST strobes, NS horn/strobes and NH horns and have the same high performance ratings. The Series Z appliances are "Special Applications" listed with Siemens panels.

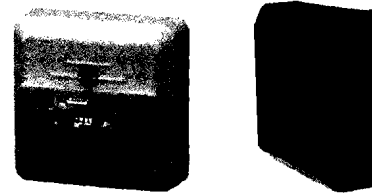

Series ZH

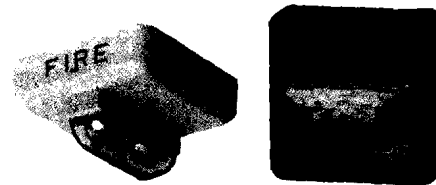

Series ZR

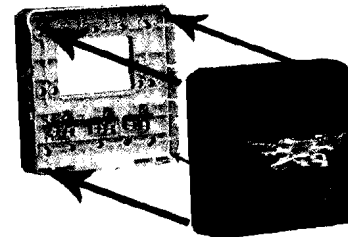

ZR AND ZH Mounting

Engineering Specifications

General

Audible/visual notification appliances shall be listed for indoor use and shall meet the requirements of FCC Part 15 Class B. These appliances shall be listed under UL Standard 1971, (Standard for Safety Signaling Devices for Hearing Impaired) and UL Standard 464 (Fire Protective Signaling). The appliances shall use a universal backplate that shall allow mounting to a single-gang, double-gang, 4-inch square, 4" octal, or a 3-1/2" octal backbox. Two wire appliance wiring shall be capable of directly connecting to the mounting back plate. Continuity checking of the entire NAC circuit prior to attaching any audible/visual notification appliances shall be allowed. A dust cover shall fit and protect the mounting plate. The dust cover shall be easily removed when the appliance is installed over the backplate. Removal of an appliance shall result in a trouble condition by the Fire Alarm Control Panel (FACP).

Strobes

Strobe appliances shall produce a minimum flash rate of 60 flashes per minute (1 flash per second) over the Regulated Input Voltage Range and shall incorporate a

Xenon flashtube enclosed in a rugged Lexan® lens. The strobes shall be available with two or four field selectable settings in one unit and shall be rated, per UL 1971, for up to 185 cd for wall mounting and 177 cd for ceiling mounting. The strobes shall operate over an extended temperature range of 32°F to 120°F (0°C to 49°C) and be listed for maximum humidity of 95% RH. Strobe inputs shall be polarized for compatibility with standard reverse polarity supervision of circuit wiring by a Fire Alarm Control Panel (FACP).

Audibles and Audible/Strobe Combinations

Horns and horn/strobes shall be listed for Indoor use under UL Standard 464. The horns shall be able to produce a continuous output or a temporal code-3 output that can be synchronized. The horns shall have at least 2 sound level settings of 90 and 95 dBA.

Synchronization Modules

When synchronization of strobes or temporal Code-3 audibles is required, the appliances shall be synchronized using the Siemens 5406B sync modules, MPC-6000 panels, MPC-7000 panels, or RSE-300 power supplies with built-in sync protocol. The strobes shall not drift out of synchronization at any time during operation. Au-

dibles and strobes shall be able to be synchronized on a 2-wire circuit with the capability to silence the audible if required. If the sync module or power supply fails to operate (i.e., contacts remain closed), the strobes shall revert to a non-synchronized flash rate. All notification appliances shall be listed for "Special Applications".

- Strobes are designed to flash at 1 flash per second minimum over their "Regulated Input Voltage Range".
- All candela ratings represent minimum effective strobe intensity based on UL Standard 1971.
- Series ZH Strobe products are listed under UL Standards 1971 and 464 for indoor use with a temperature range of 32°F to 120°F (0°C to 49°C) and maximum humidity of 93% (± 2%).
- Series ZH horns are listed under UL Standard 464 for audible signal appliances (Indoor use only).

Technical Information

For complete technical information, please consult the relevant installation sheets as well as the Siemens Compatibility Guide.

Ordering Information / Mounting Requirements / Approvals

Model Number	Order Code	Mounting Options#	Agency Approvals			
			UL	ULC	CSFM	FM
ZH-MC-R	500-636161	B, D, E, F	X	#	#	#
ZH-MC-W	500-636162	B, D, E, F	X	#	#	#
ZH-HMC-R	500-636163	B, D, E, F	X	#	#	#
ZH-HMC-W	500-636164	B, D, E, F	X	#	#	#
ZH-R	500-636159	B, D, E, F	X	#	#	#
ZH-W	500-636160	B, D, E, F	X	#	#	#
ZH-MC-CR	500-636165	B, D, E, F	X	#	#	#
ZH-MC-CW	500-636166	B, D, E, F	X	#	#	#
ZH-HMC-CR	500-636167	B, D, E, F	X	#	#	#
ZH-HMC-CW	500-636168	B, D, E, F	X	#	#	#
ZR-MC-R	500-636169	B, D, E, F	X	#	#	#
ZR-MC-W	500-636170	B, D, E, F	X	#	#	#
ZR-HMC-R	500-636171	B, D, E, F	X	#	#	#
ZR-HMC-W	500-636172	B, D, E, F	X	#	#	#
ZR-MC-CW	500-636174	B, D, E, F	X	#	#	#
ZR-MC-CR	500-636173	B, D, E, F	X	#	#	#
ZR-HMC-CR	500-636175	B, D, E, F	X	#	#	#
ZRS-HMC-CW	500-636176	B, D, E, F	X	#	#	#
ZBB-R	500-636193	Accessory - Includes base, dust cover, mounting screws and installation sheet				
ZBB-W	500-636194	Accessory - Includes base, dust cover, mounting screws and installation sheet				

X = listed/approved # = pending * = Refer to Data Sheet #9675 for mounting options.

WARNING: PLEASE READ THESE SPECIFICATIONS AND INSTALLATION INSTRUCTIONS CAREFULLY BEFORE USING, SPECIFYING OR APPLYING THIS PRODUCT. FAILURE TO COMPLY WITH ANY OF THESE INSTRUCTIONS, CAUTIONS AND WARNINGS COULD RESULT IN IMPROPER APPLICATION, INSTALLATION AND/OR OPERATION OF THESE PRODUCTS IN AN EMERGENCY SITUATION, WHICH COULD RESULT IN PROPERTY DAMAGE, AND SERIOUS INJURY OR DEATH TO YOU AND/OR OTHERS.



Siemens Building Technologies, Inc.
 8 Fernwood Road • Florham Park, NJ 07932
 Tel: (973) 593-2600 • Fax: (973) 593-6670
 Web: www.faradayfirealarms.com

Mounting Matrix and Details

(A) UNIVERSAL MOUNTING PLATE

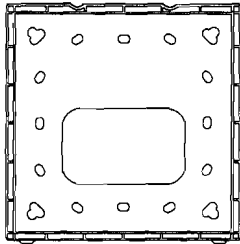

"AS" Mounting (item included with AS series devices)

(B) SINGLE-GANG, FLUSH (BO)

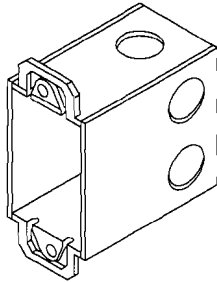

MAXIMUM NUMBER OF CONDUCTORS

AWG. #18	AWG. #16	AWG. #14	AWG. #12
4	4	4	4

Used with Series AH, AS, MH, NH, NS, ST

(D) 4" SQUARE, FLUSH (BO)

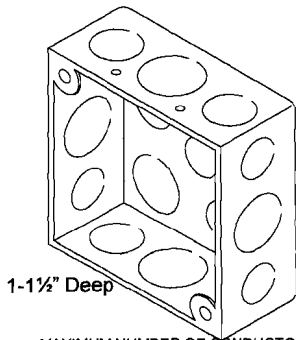

1-1/2" Deep

MAXIMUM NUMBER OF CONDUCTORS

AWG. #18	AWG. #16	AWG. #14	AWG. #12
4	4	4	4

Used with Series MH115, B6, B10, AH, AS, HS, MBDC, MTH, NH, NS, ST

(E) 4" SQUARE, DEEP, FLUSH (BO)

2-1/8" Deep

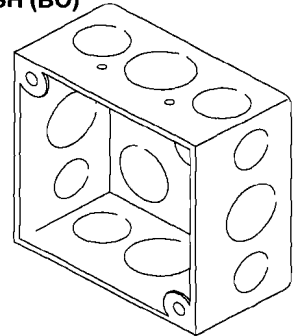

MAXIMUM NUMBER OF CONDUCTORS

AWG. #18	AWG. #16	AWG. #14	AWG. #12
8	8	8	8

Used with Series MH115, B6, B10, AH, AS, SETSF, SET-ULC, HS, MBDC, MTH, NH, NS, ST

(F) DOUBLE-GANG, FLUSH (BO)

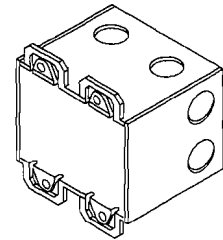

MAXIMUM NUMBER OF CONDUCTORS

AWG. #18	AWG. #16	AWG. #14	AWG. #12
4	4	4	4

Used with Series AH, AS, HS, MT, NH, NS, ST

(G) DOUBLE-GANG, SURFACE (BO)

L	W
4-7/8"	4-3/4"
D.	GANG #
1-3/4"	2

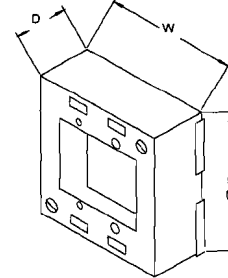

MAXIMUM NUMBER OF CONDUCTORS

AWG. #18	AWG. #16	AWG. #14	AWG. #12
4	4	4	4

Used with Series AH, AS, NH, NS, ST

(I) WPBBS (ORDER CODE: RED 500-636137)

Plastic backbox for surface mounting series AS weather-proof outdoor products.

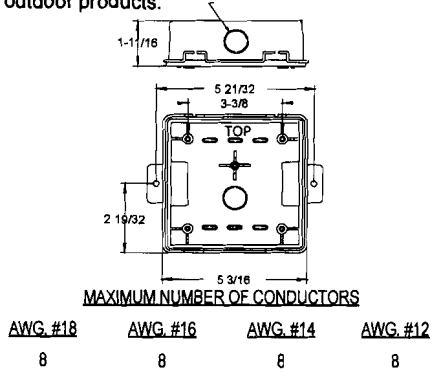

(M) MT-SUR-BOX BACKBOX (ORDER CODES: RED 500-693168, WHITE 500-636118)

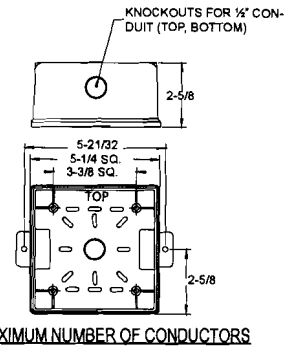

Used with Series SET, HS, MTH, MTWP. For surface mounting MT products.

(J) BBS BACKBOX (ORDER CODES: RED 500-636110)

Standard steel backbox with knockouts for interior surface mounting, concealed conduit mounting or semi-flush applications.

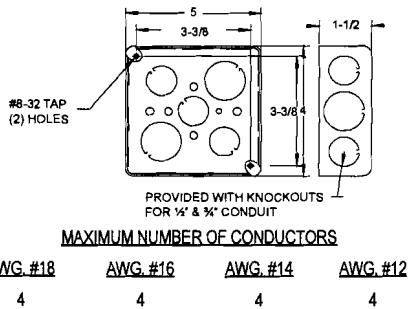

Used with Series MH115, B6, B10, AH, AS, MBDC, MTH-15-115, NH, NS, ST

(N) DBBS BACKBOX (ORDER CODE: RED 500-636111)

Standard steel backbox provided with knockouts for interior surface mounting, concealed conduit mounting or semi-flush applications.

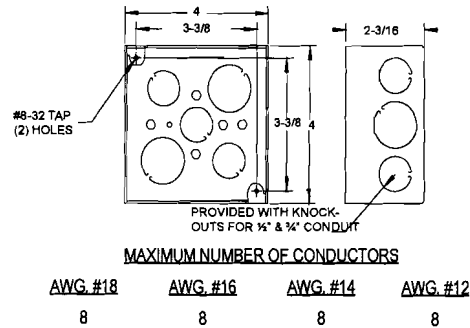

Used with Series MH115, B6, B10, AH, AS, SETSF, HS, MBDC, MTH, NH, NS, ST

(K) WBBS WEATHER RESISTANT BACKBOX (ORDER CODES: RED 500-636129, WHITE 500-636131)

Sturdy die cast housing, threaded conduit hole and knockout for outdoor applications.

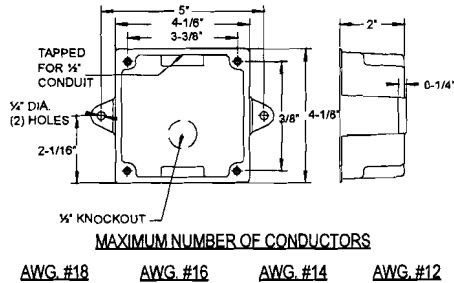

Used with Series MH115, B6, B10, SETSF, MBDC, MTH-15-115

(P) SBBS BACKBOX (ORDER CODES: RED 500-636119, WHITE 500-636120)

For surface mounting speakers, chimes, and electronic applications.

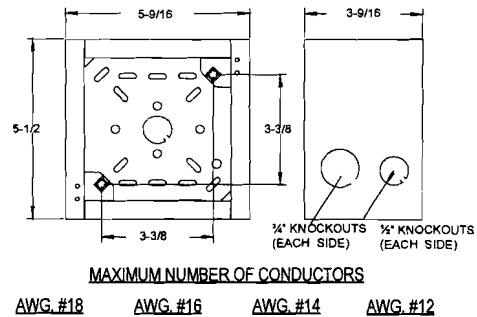

Used with Series B6, B10, CH, SEF, SET, SETFL, HS, MBDC, MTH, NH, NS, ST

(Q) 4" SQUARE DEEP W/ EXTENSION RING, FLUSH (BO)

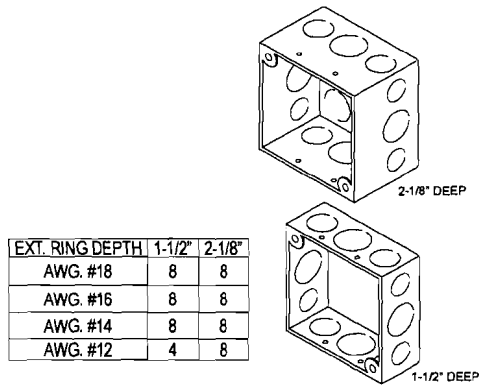

EXT. RING DEPTH	1-1/2"	2-1/8"
AWG. #18	8	8
AWG. #16	8	8
AWG. #14	8	8
AWG. #12	4	8

Used with Series CH, SEF, SET, SETFL

(T) WPSBBS (ORDER CODES: RED 500-636139, WHITE 500-636140)

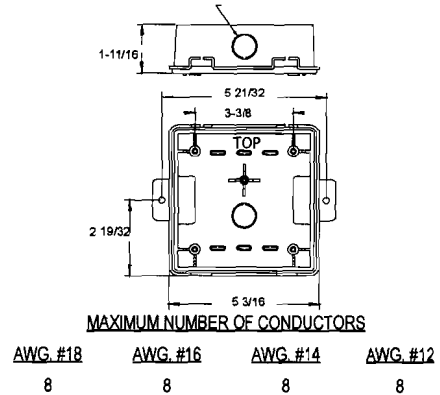

MAXIMUM NUMBER OF CONDUCTORS

AWG. #18	AWG. #16	AWG. #14	AWG. #12
8	8	8	8

Used with Series ST-WP

(R) SFPS SEMI-FLUSH PLATE (ORDER CODES: RED 500-636124, WHITE 500-636125)

Stamped aluminum surface wall plate which mounts behind the basic unit and serves to cover recessed backboxes in semi-flush mounting applications.

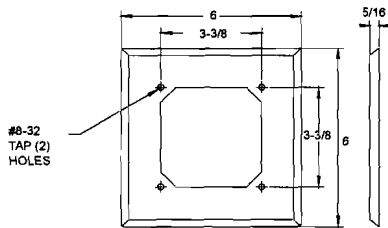

Used with Series MT, SET, SE, NH, NS, ST

(U) 5" SQUARE BACKBOX W/ EXTENSION RING, FLUSH (BO)

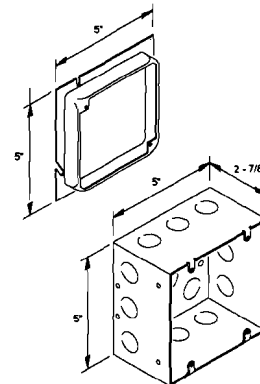

(S) APS ADAPTER PLATE (ORDER CODE: RED 500-630109)

Stamped aluminum adapter plate designed for applications where semi-flush installations cannot be used. The plate can be mounted to standard octagon or round backboxes single or double gang boxes or plaster rings. The backbox and basic unit are then fastened to the plate. This type mounting is referred to as a concealed conduit installation.

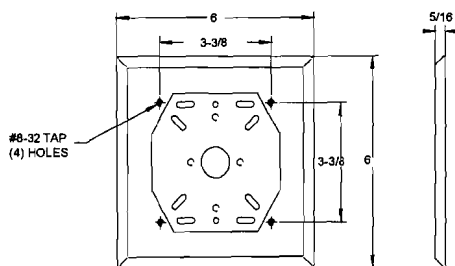

Used with Series MBDC

(W) 4 1/16" SQUARE, DEEP SURFACE (BO)

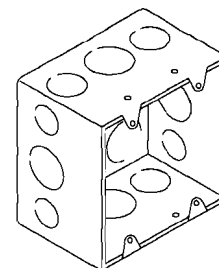

MAXIMUM NUMBER OF CONDUCTORS

AWG. #18	AWG. #16	AWG. #14	AWG. #12
10	10	10	10

(X) SHBBS SQUARE, SURFACE BACKBOX
 (Order Codes: Red 500-636126, White 500-636127)

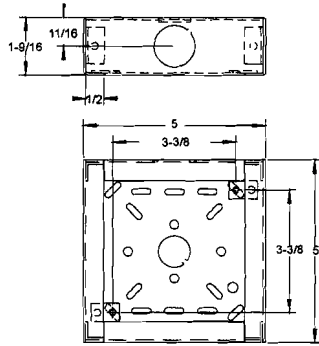

Used with Series AS, AH, NS, Z

(BB) SPSSB (ORDER CODES: RED 500-636114, WHITE 500-636115)

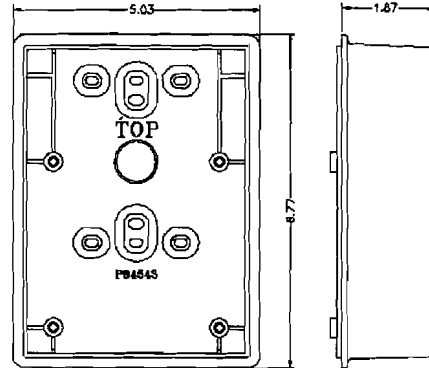

Used with Series SE-MC/HMC
 (wall mount speaker/ strobe)

(Y) SERS SQUARE SEMI-FLUSH EXTENSION RING (Order Codes: Red 500-636122, White 500-636123)

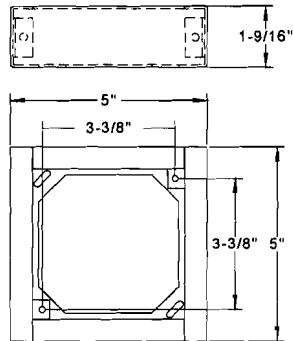

Used with Series CH, SEF, SET

(CC) SB-W 8" CEILING SUPPORT BRIDGE (ORDER CODE: WHITE 500-634882)

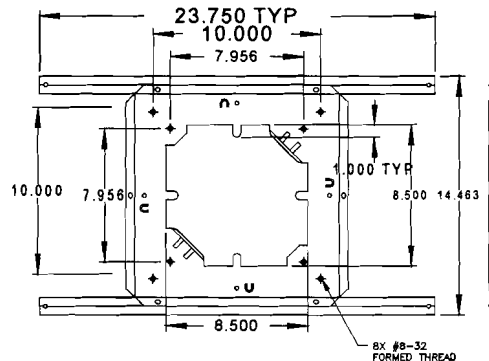

Used with Series S 8" Ceiling Speakers

(Z) SBL2S BACKBOX (Order Codes: RED 500-636121)

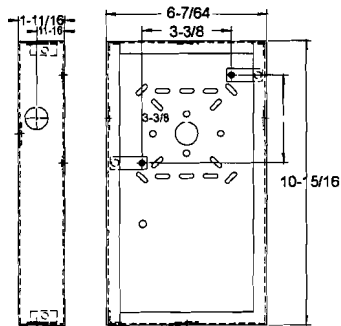

(AA) SPSB (Order Codes: Red 500-636112, White 500-636113)

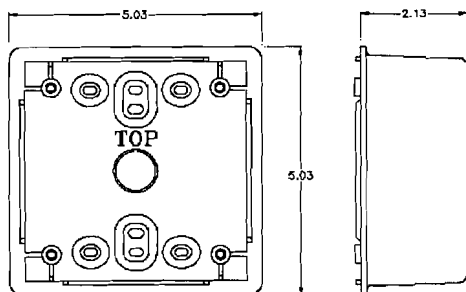

Used with Series SE Speakers

(DD) SE-1 8" CEILING SPEAKER BACKBOX (ORDER CODE: WHITE: 500-634881)

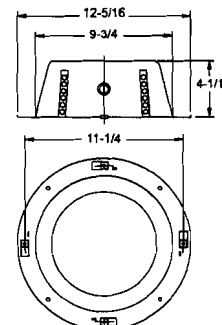

Used with 8" Ceiling Speakers

(EE) SPEXT EXTENSION RING (ORDER CODE: RED 500-636116, WHITE 500-636117)

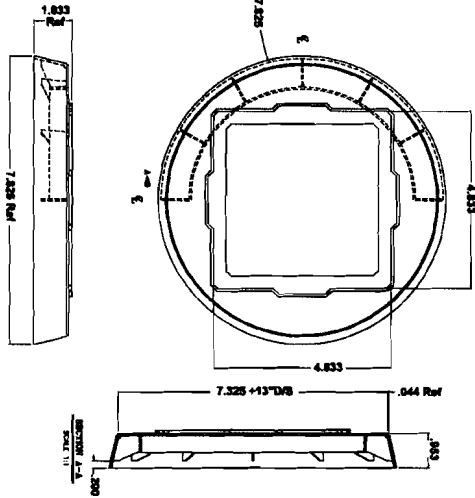

Used with Series SE-MC-C (ceiling mount strobe)

(FF) ZBB (ORDER CODES: RED 500-636193, WHITE 500-636194)

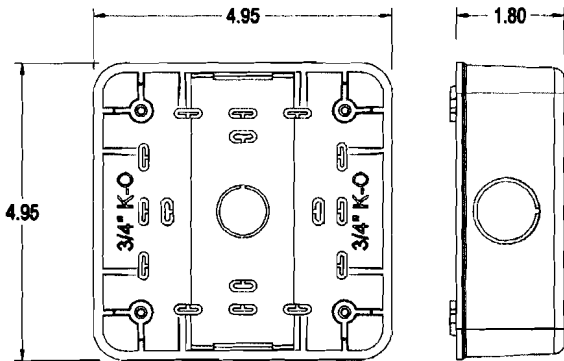

Used with Series Z

(GG) WFPS PLATE (ORDER CODES: RED 500-636135, WHITE 500-636136)

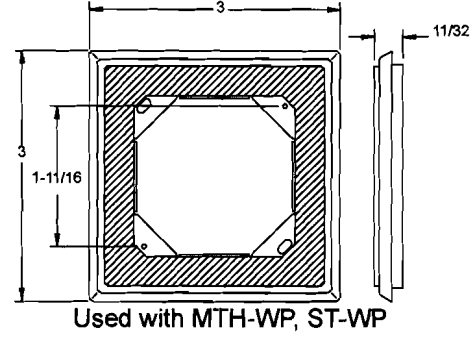

(HH) WFPAS PLATE (Order Codes: Red 500-363133, White 500-656134)

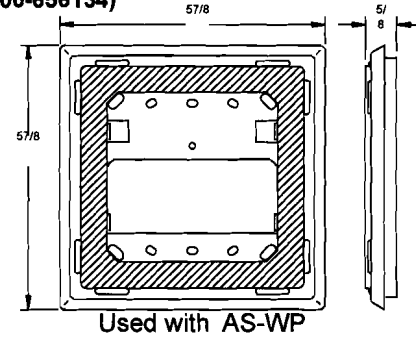

MOUNTING MATRIX

	Series SET-C	Series ST	Series ST-MC-RETRO	Series MH115	Series SE	Series B10-115	Series CH	Series SETSF-B	Series SETSF	Series MBDC	Series SET/SET Wall Mount	Series SE-C	Series MH	Series MTH	Series NH/NS	Series HS	Series AS/AH	Series AH-WB(3), MT-WP(4), MTH	Series Z
(A) Universal Mounting Plate (included with AS series devices)																	X		
(B) 1-GANG x 2" Deep - Flush (BO)		X											X		X		X		X
(D) 4" x 4" x 1.5" Deep - Flush (BO)		X	X	X		X			X						X		X		X
(E) 4" x 4" x 2.125" Deep - Flush (BO)		X	X	X	X	X		X	X					X	X	X	X		X
(F) 2-Gang x 3.5" Deep - Flush (BO)		X												X	X	X	X		X
(G) 2-Gang x 1.75" Deep - Surface (BO)		X													X		X		
(I) WPBBS-R Weatherproof Backbox for AS-WP																			2
(J) BBS Surface (SP) Note 9		X		X	X				X						X				
(K) WBBS Weatherproof (SP)				X	X				X	X							X		3
(M) MT-SUR-BOX Surface & Weatherproof (SP)										X	X			X		X			4
(N) DBBS Surface (SP)		X		X	X				X	X				X	X	X			
(P) SBBS Surface (SP)	X	X			X	X	X		X	X				X	X	X	X		
(Q) 4" x 4" x 2.125" Box w/ 1.5" Extension Ring- Flush (BO)	X		X			X	X				X	X							
(R) SPT Semi-Flush Plate (SP)		X		X	X	X	X		X	X				X	X	X	X		
(S) APS Adapter Plate (SP)					X				X	X	X								
(T) WPSBBS-R Weatherproof Backbox for ST-WP																			1
(U) 5" Square Backbox w/ Extension Ring, Flush (BO)	X						X	X				X							
(V) 4.6875" x 4.6785" x 2.125" Deep Surface (BO)																			
(X) SHBBS (SP) Shallow Surface		X				X				X					X		X		
(Y) SERS Semi-Flush Extension Ring (Retrofit Appl.)	X						X				X								
(Z) SBLS-2 Surface (SP)		X	X	X		X	X	X	X										
(AA) SPSB Backbox for SE Speaker					X														
(BB) SPSSB Backbox for SE Speaker Strobe					X														
(EE) SPECT Extension Ring												X							
(FF) ZBB																			X

MOUNTING NOTES

Caution: The mounting options figures show the maximum number of field wires (conductors) that can enter the backbox used with each mounting option. If these limits are exceeded, there may be insufficient space in the backbox to accommodate the field wires and stresses from the wires could damage the product.

Although the limits shown for each mounting option comply with the National Electrical code (NEC), Siemens recommends use of the largest backbox option and the use of approved field wires whenever possible, to provide additional wiring room for easy installation and minimum stress on the product from wiring.

Caution: Check that the installed product will have sufficient clearance and wiring room prior to installing backboxes and conduit, especially if sheathed multiconductor cable or 3/4" conduit fittings are used.

1. Mounting hardware for each mounting option is supplied.
2. Conduit entrances to the backbox should be selected to provide sufficient wiring clearance for the installed product. When extension rings are required, conduit should enter through the backbox, not the extension ring. Use Steel City #53151 (1-1/2" deep) or #53171 (2-1/8" deep) extension rings (as noted in the mounting options) or equal with the same cut-out area.

3. When terminating field wires, do not use more lead length than required. Excess lead length could result in insufficient wiring space for the appliance.
4. Use care and proper techniques to position the field wires in the backbox so that they use minimum space and produce minimum stress on the product. This is especially important for stiff, heavy gauge wires and wires with thick insulation or sheathing.
5. Do not pass additional wires (used for other than the appliance) through the backbox "unless the backbox is of a sufficient size to permit additional wiring as described in NEC 314.16 (B)". Such additional wires could result in insufficient wiring space for the appliance.

NOTE: Due to continuous development of our products, specifications and offerings are subject to change without notice in accordance with Siemens Inc. standard terms and conditions.

BACKBOX MOUNTING HEIGHTS for SIEMENS WALL MOUNTED HORIZONTAL STROBE APPLIANCES NFPA-72 (2007)

7.5.4.1* Wall-mounted appliances shall be mounted such that the entire lens is not less than 2030 mm (80 in.) and not greater than 2440 mm (96 inc.) above the finished floor or at the mounting height specified using the performance-based alternative 7.5.4.5

7.5.4.2 Where low ceiling heights do not permit mounting at a minimum of 2030 mm (80 in.), visible appliances shall be mounted within 150 mm (6 in.) of the ceiling. The room size covered by a strobe of a given value shall be reduced by twice the difference between the minimum mounting height of 2030 mm (80 inc.) and the actual, lower mounting height.

Backbox Mounting Options*	Series AS/AH Audible Strobe		Series ST-MC-RETRO Flush and Surface Retrofit Plate		Series NS Horn Strobe		Series Z and ST Strobe		Series MTH Multitone	
	80 IN	6 IN	80 IN	6 IN	80 IN	6 IN	80 IN	6 IN	80 IN	6 IN
(B) 1-Gang x 2" Deep - Flush (BO)	77 1/2"	8 1/2"			78 3/8"	7 5/8"	79 1/8"	6 7/8"		
(D) 4" x 4" x 1.5" Deep - Flush (BO)	77"	9"	83 15/16"		77 7/8"	8 1/8"	78 5/8"	7 3/8"	79 15/16"	6 1/16"
(E) 4" x 4" x 2.125" Deep - Flush (BO)	77"	9"	83 15/16"		77 7/8"	8 1/8"	78 5/8"	7 3/8"	79 15/16"	6 1/16"
(F) 2-Gang x 3.5" Deep - Flush (BO)	77 1/2"	8 1/2"			78 3/8"	7 5/8"	79 1/8"	6 7/8"	80 9/16"	5 7/16"
(G) 2-Gang x 1.75" Deep - Surface (BO)	77 1/2"	8 1/2"			78 3/8"	7 5/8"	79 1/8"	6 7/8"	80 9/16"	5 7/16"
(M) MT-SUR-BOX Surface & Weatherproof (SP)									79 3/8"	6 5/8"
(P) SBBS Surface (SP)									79 1/4"	6 3/4"
(Q) 4" x 4" x 2.125" Box w/ 1.5" Extension Ring - Flush (BO)										
(U) 5" Square Backbox w/ Extension Ring, Flush (BO)	69 1/2"	8 1/2"	83 7/16"		77 3/8"	7 5/8"	78 1/8"	6 7/8"	79 7/16"	5 9/16"
(X) SHBBS (SP) Shallow Surface	76 1/2"	9 1/2"			77 3/8"	8 5/8"	78 1/8"	7 7/8"		
(Y) 4" x 4" x 1.5" Box w/ 1.5" Extension Ring Plate (BO)										
(Z) SBL2S Surface (SP)			78"							
(FF) ZBB							78 1/8"	7 7/8"		

Backbox Mounting Options*	Series CH Chime Strobe		Series SET-V Speaker Strobe		Series SEF-C Speaker Strobe		Series SET-C Speaker Strobe	
	80 IN	6 IN	80 IN	6 IN	80 IN	6 IN	80 IN	6 IN
(P) SBB Surface (SP)	77 3/4"	8 1/4"	79 3/16"	6 13/16"	77 3/4"	8 1/4"	77 3/4"	8 1/4"
(Q) 4" x 4" x 2.125" Box w/ 1.5" Extension Ring - Flush (BO)	77 1/2"	7 1/2"	80"	6"	78 1/2"	7 1/2"	78 1/2"	7 1/2"
(U) 5" Square Backbox w/ Extension Ring - Flush (BO)	78"	7"	79 1/2"	5 1/2"	78"	7"	78"	7"
(X) SHBB (SP) Shallow Surface								
(Y) 4" x 4" x 1.5" Box w/ 1.5" Extension Ring Plate - Flush (BO)	78 1/2"	7 1/2"	80"	6"				

* Measured from Bottom of Backbox

NOTES: (BO) = By Others (SP) = Siemens Product

WARNING: PLEASE READ THESE SPECIFICATIONS AND INSTALLATION INSTRUCTIONS CAREFULLY BEFORE USING, SPECIFYING OR APPLYING THIS PRODUCT. FAILURE TO COMPLY WITH ANY OF THESE INSTRUCTIONS, CAUTIONS AND WARNINGS COULD RESULT IN IMPROPER APPLICATION, INSTALLATION AND/OR OPERATION OF THESE PRODUCTS IN AN EMERGENCY SITUATION, WHICH COULD RESULT IN PROPERTY DAMAGE, AND SERIOUS INJURY OR DEATH TO YOU AND/OR OTHERS.



Siemens Building Technologies, Inc.
8 Fernwood Road • Florham Park, NJ 07932
Tel: (973) 593-2600 • Fax: (973) 593-6670
Web: www.faradayfirealarms.com

8/07 2M SBT/IG

August 2007 - New Issue



Photoelectric Smoke Detectors

System Sensor's *i³*™ series smoke detectors represent significant advancement in conventional detection. The *i³* family is founded on three principles: installation ease, intelligence, and instant inspection.

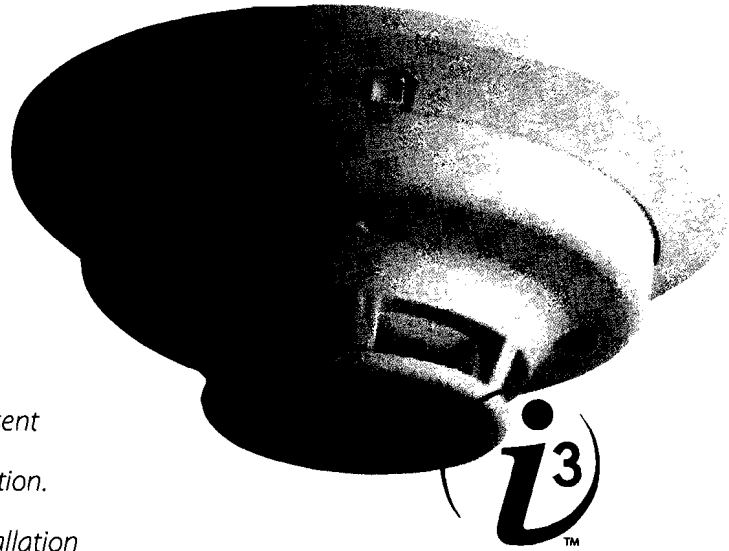

Features

- Plug-in detector line, mounting base included
- Large wire entry port
- In-line terminals with SEMS screws
- Mounts to octagonal and single-gang backboxes, 4-square backboxes, or direct to ceiling
- Stop-Drop 'N Lock attachment to base
- Removable detector cover and chamber
- Built-in remote maintenance signaling
- Drift compensation and smoothing algorithms
- Simplified sensitivity measurement
- Wide angle, dual color LED indication
- Loop testing via EZ Walk feature
- Built-in test switch

Installation ease. The *i³* line redefines installation ease with its plug-in design. This allows an installer to pre-wire the bases included with the heads. The large wire entry port and in-line terminals provide ample room for neatly routing the wiring inside the base. The base accommodates a variety of back box mounting methods, as well as direct mounting with drywall anchors. To complete the installation, *i³* heads plug in to the base with a simple Stop-Drop 'N Lock™ action.

Intelligence. *i³* detectors offer a number of intelligent features to simplify testing and maintenance. Drift compensation and smoothing algorithms are standard with the *i³* line to minimize nuisance alarms. Two-wire *i³* detectors needing cleaning can generate a remote maintenance signal, when connected to the 2W-MOD2 loop test/maintenance module, or to a panel equipped with the *i³* protocol. This signal is indicated by LEDs located at the module and the panel. The SENS-RDR, a wireless device, displays the sensitivity of *i³* detectors in terms of percent per-foot-obscuration.

Instant inspection. The *i³* series provides wide-angle red and green LED indicators for instant inspection of the detector's condition: normal standby, out-of-sensitivity, alarm, or freeze trouble. When connected to the 2W-MOD2 loop test/maintenance module or a panel with the *i³* protocol, the EZ Walk loop test feature is available on two-wire *i³* detectors. This feature verifies the initiating loop wiring by providing LED status indication at each detector.

Agency Listings



Smoke Detector Specifications

Architectural/Engineering Specifications

Smoke detector shall be a System Sensor P Series model number _____, listed to Underwriters Laboratories UL 268 for Fire Protection Signaling Systems. The detector shall be a photoelectric type (Model 2W-B, 4W-B) or a combination photoelectric/thermal (Model 2WT-B, 4WT-B) with thermal sensor rated at 135°F (57.2°C). The detector shall include a mounting base for mounting to 3½-inch and 4-inch octagonal, single gang, and 4-inch square back boxes with a plaster ring, or direct mount to the ceiling using drywall anchors. Wiring connections shall be made by means of SEMS screws. The detector shall allow pre-wiring of the base and the head shall be a plug-in type. The detector shall have a nominal sensitivity of 2.5 percent-per-foot nominal as measured in the UL smoke box. The detector shall be capable of automatically adjusting its sensitivity by means of drift compensation and smoothing algorithms. The detector shall provide dual color LED indication which blinks to indicate power up, normal standby, out of sensitivity, alarm, and freeze trouble (Model 2WT-B, 4WT-B) conditions. When used in conjunction with the 2W-MOD2 module, 2-wire models shall include a maintenance signal to indicate the need for maintenance at the alarm control panel, and shall provide a loop testing capability to verify the circuit without testing each detector individually.

Electrical Specifications

Operating Voltage	Nominal: 12/24V non-polarized Minimum: 8.5V Maximum: 35V
Maximum Ripple Voltage	30% peak to peak of applied voltage
Standby Current	2-wire: 50 µA maximum average; 4-wire: 50 µA maximum average
Maximum Alarm Current	2-wire: 130 mA limited by control panel; 4-wire: 20 mA @ 12V, 23mA @ 24V
Peak Standby Current	2-wire: 100 µA; 4-wire: n/a
Alarm Contact Ratings	2-wire: n/a; 4-wire: 0.5 A @ 30V AC/DC

Physical Specifications

Dimensions (including base)	5.3 inches (127 mm) diameter; 2.0 inches (51 mm) height
Weight	6.3 oz. (178 grams)
Operating Temperature Range	2W-B and 4W-B: 32°F–120°F (0°C–49°C); 2WT-B and 4WT-B: 32°F–100°F (0°C–37.8°C)
Operating Humidity Range	0 to 95% RH non-condensing
Thermal Sensor	135°F (57.2°C) fixed
Freeze Trouble	2WT-B and 4WT-B only: 41°F (5°C)
Sensitivity	2.5%/ft. nominal
Input Terminals	14–22 AWG
Mounting	3½-inch octagonal back box 4-inch octagonal back box Single gang back box 4-inch square back box with a plaster ring Direct mount to ceiling

LED Modes			Power Up Sequence for LED Indication	
LED Mode	Green LED	Red LED	Condition	Duration
Power up	Blink every 10 seconds	Blink every 10 seconds	Initial LED status indication	80 seconds
Normal (standby)	Blink every 5 seconds	off		
Out of sensitivity	off	Blink every 5 seconds		
Freeze trouble	off	Blink every 10 seconds		
Alarm	off	Solid		

Ordering Information

Model	Thermal	Wiring	Alarm Current
2W-B	No	2-wire	130 mA max. limited by control panel
2WT-B	Yes	2-wire	130 mA max. limited by control panel
4W-B	No	4-wire	20 mA @ 12V, 23mA @ 24V
4WT-B	Yes	4-wire	20 mA @ 12V, 23mA @ 24V

Accessories

2W-MOD2	2-wire loop test / maintenance module	RT	Removal / replacement tool
SENS-RDR	Sensitivity reader	A77-AB2	Retrofit adapter bracket, 6.6 in. (16.76cm) diameter



3825 Ohio Avenue • St. Charles, IL 60174
Phone: 800-SENSOR2 • Fax: 630-377-6495

©2006 System Sensor.
Product specifications subject to change without notice. Visit systemsensor.com for current product information, including the latest version of this data sheet.
A05-0318-006 • 7/06 • #1676



D8004 Transformer Enclosure

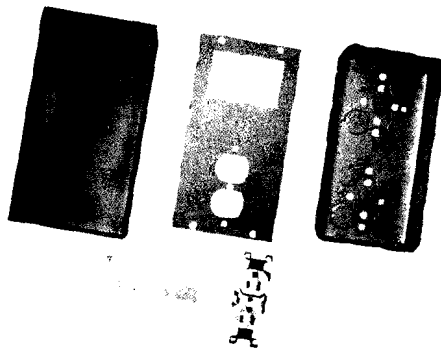

The D8004 Transformer Enclosure protects the AC plug-in transformer and ensures that it remains securely fixed to the AC wall outlet. The D8004 Transformer Enclosure may be required for certain applications; the most common being fire alarm.

Environmental Considerations

Environment: Indoor, dry

Mechanical Properties

Cover

Color: Light gray
 Dimensions: 8.8 in. x 4.7 in. x 3.0 in.
 (22.4 cm x 11.9 cm x 7.6 cm)

Material: Cold-rolled steel, 18 gauge (1.2 mm)

Outlet Box

Dimensions: 8.7 in. x 4.6 in. x 1.7 in.
 (22.1 cm x 11.7 cm x 4.3 cm)

Material: Galvanized steel, 18 gauge (1.2 mm)

Power Requirements

Voltage (supply): 120 VAC

Region	Certification
USA	UL AMCX: Central Station Alarm Units (UL1610, UL1635), AOTX: Local Alarm Units (UL464, UL609), APAX: Police Station Alarm Units (UL365, UL464), NBSX: Household Burglar Alarm System Units (UL1023), UOXX: Control Unit Accessories, System (UL864, 9th edition), UTOU: Control Units and Accessories - Household System Type (UL985)
	FM CSFM 7167-1615: 100, 7165-1615: 112, 7165-1615: 119
	NYC-MEA 12-92-E, Vol. 12 12-92-E, Vol. 15

D8004 Transformer Enclosure

For applications such as fire alarm that might require a transformer enclosure.

D8004

Americas:
Bosch Security Systems, Inc.
130 Perinton Parkway
Fairport, New York, 14450, USA
Phone: +1 800 289 0096
Fax: +1 585 223 9180
security.sales@us.bosch.com
www.boschsecurity.us

Europe, Middle East, Africa:
Bosch Security Systems B.V.
P.O. Box 80002
5600 JB Eindhoven, The Netherlands
Phone: + 31 40 2577 284
Fax: +31 40 2577 330
emea.securitysystems@bosch.com
www.boschsecurity.com

Asia-Pacific:
Robert Bosch (SEA) Pte Ltd, Security Systems
11 Bishan Street 21
Singapore 573943
Phone: +65 6571 2600
Fax: +65 6571 2698
apr.securitysystems@bosch.com
www.boschsecurity.com

Represented by

NO EXCUSES!

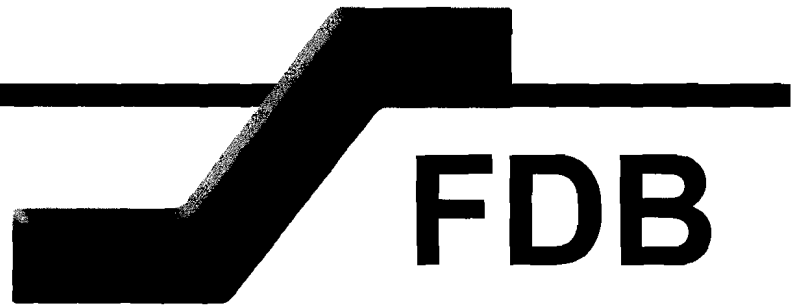

Fire Alarm Control Unit (FACU) Records & Document Box

The Space Age FDB has been developed to be a code compliant solution to a mandated item specified by the National Fire Code (NFPA 72).

An internal galvanized sleeve holds the documents safely and securely. Access to the documents is via a high security CAT 30 Lock Set.

The galvanized sleeve also contains 2 hooks for key rings or thumb drives, a place for several business cards, a cutout for a 1.4 Oz. can of test gas and a slot where a standard CD "jewel" case can be stored.

Held in by two "wing nuts" the sleeve is easily removable to allow storage of a 1.5" 3 ring binder.

The door reads "FACU MAINTENANCE RECORDS" in 1" tall white lettering. Custom Logo and Lock Sets are available upon request.

NFPA 72 section 6.2.2.1 states, "A record of installed software and firmware version numbers shall be maintained at the location of the fire alarm control unit." The FDB is large enough to hold Operating Manuals, Permits, Shut-Down Instructions and more.

Standard Features:

- Overall Dimensions are:
12" Wide x 13.1" High x 2.25" Deep
- CAT 30 Secured Locking Door
- Piano Hinged Door w/Notes Sticker
- Removable document holder can hold 1" of 8.5" x 11" paperwork
- Powder Coat Red Finish
- 16 Gauge CRS construction
- Embossed:
Key Ring Hooks
Business Card Holder
CD Case Slot
- 1.4 Oz. can of detector test gas
- Private labeling available

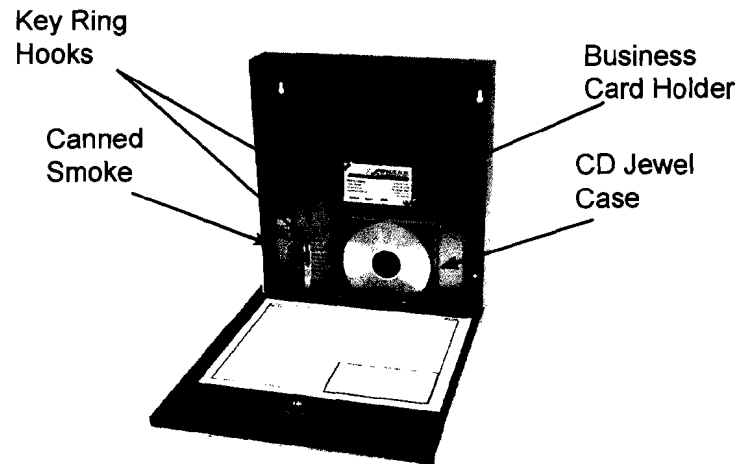

Space Age Electronics, Inc.
www.1sae.com
800.486.1723 Toll Free
508.485.0966 Local
508.485.4740 Fax

