

OCCUPANT LOAD
 AREA = 1052 SQUARE FEET
 BUSINESS OCCUPANCY = 100 SQ. FT. PER OCCUPANT
 1052/100 = 11
 OCCUPANT LOAD = 11 PEOPLE

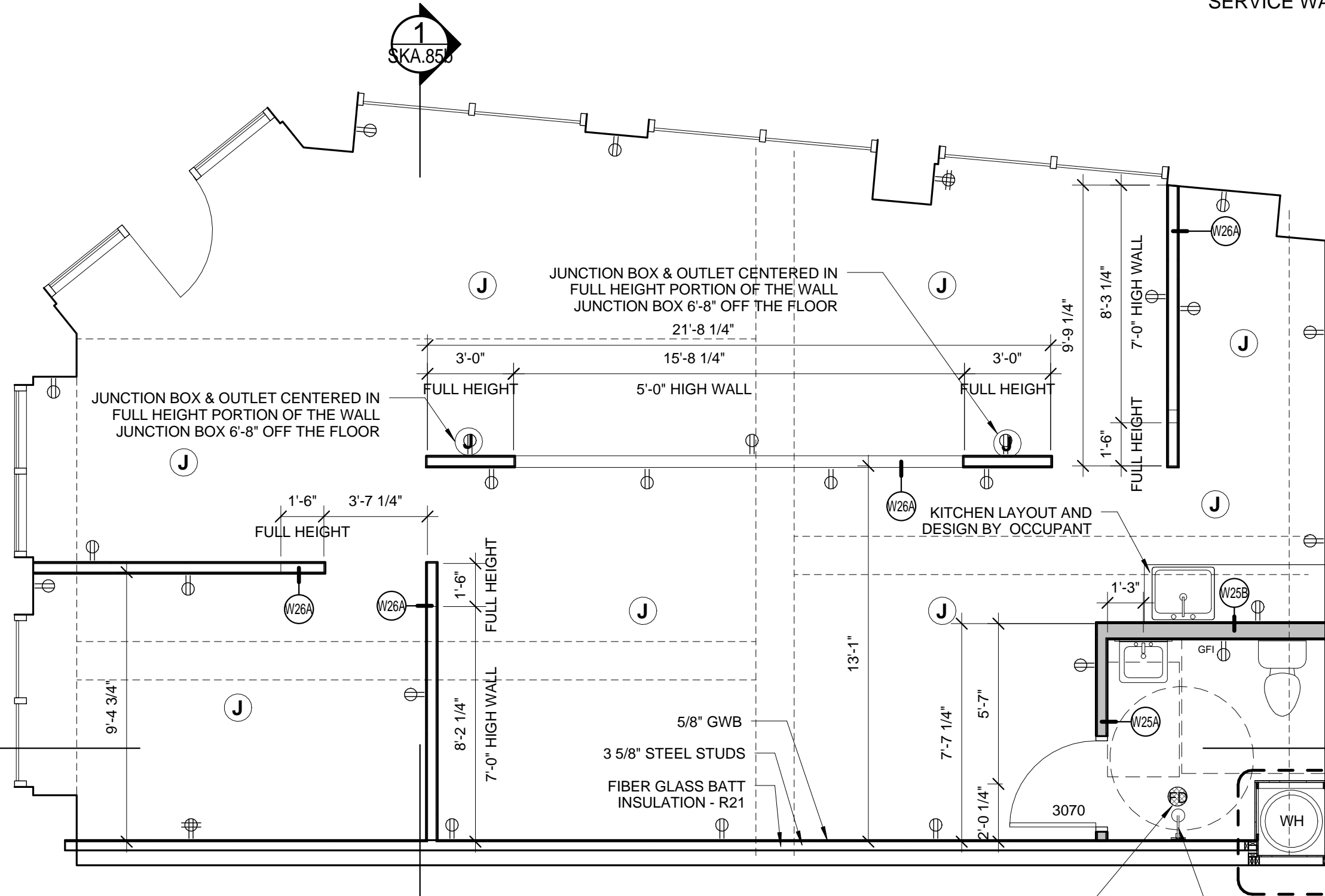

1 | 1ST FLOOR - BUSINESS A PLAN
 1/4" = 1'-0"
 0 1'-0" 2'-0" 4'-0" 8'-0"

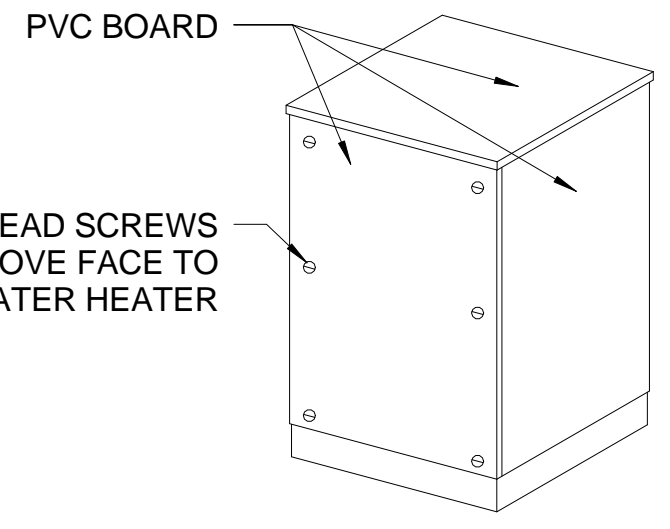

3 | W.H. ENCLOSURE
 1/4" = 1'-0"

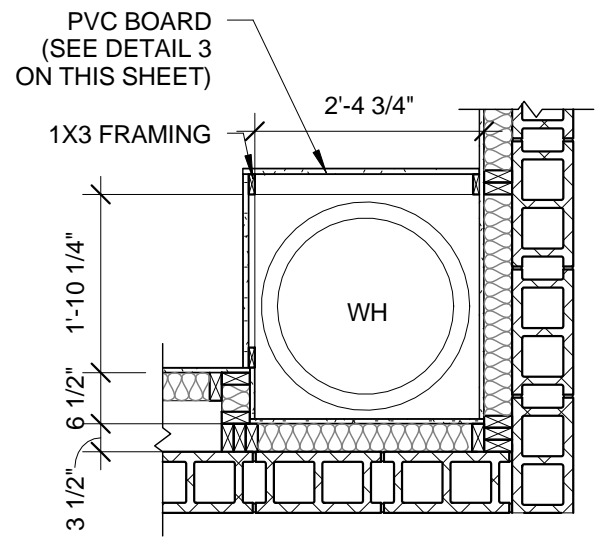

2 | PLAN DETAIL
 1/2" = 1'-0"

2 SKA.85b
 2 SKA.85c

LOCATE FLOOR DRAIN AS CLOSE TO SHOWER HEAD LOCATION AS POSSIBLE

Architect:
ARCHETYPE
 architects
 48 Union Wharf Portland, Maine 04101
 (207) 772-6022 Fax (207) 772-4056

Date: May 12, 2015
 Scale: As indicated
 Project: 118 ON MUNJOY HILL
 SPACEA - LAYOUT

118 CONGRESS STREET PORTLAND, MAINE

SKA.85c