

1 CONDO UNIT GAS WATER HEATER PIPING DIAGRAM
 TYP SCALE: NONE

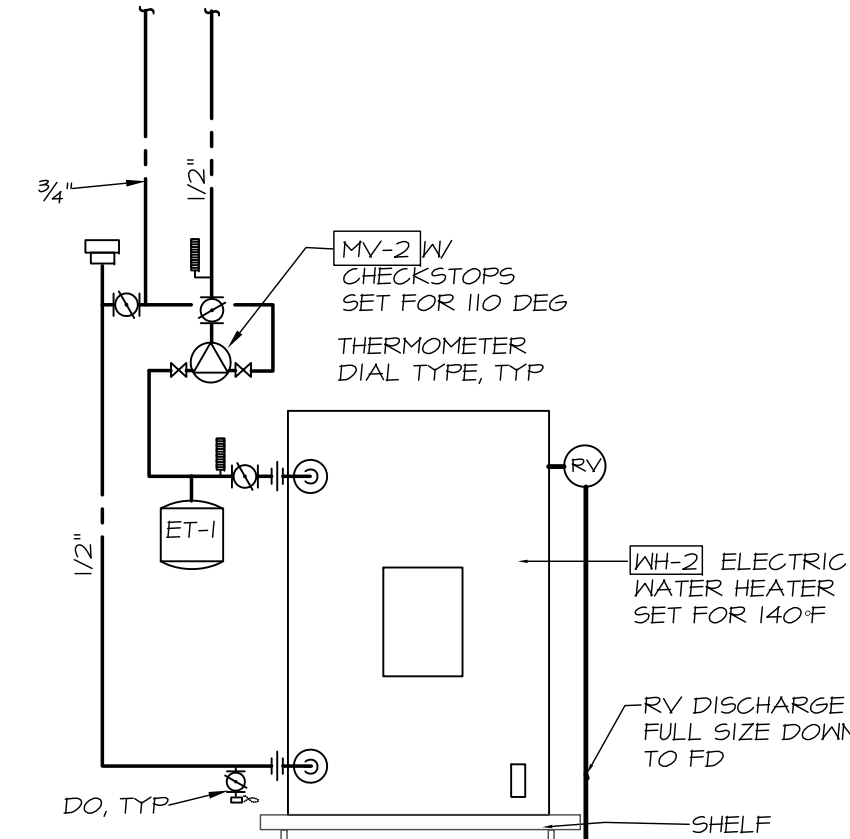

2 DOG WASH ELECTRIC WATER HEATER PIPING DIAGRAM
 P2 SCALE: NONE

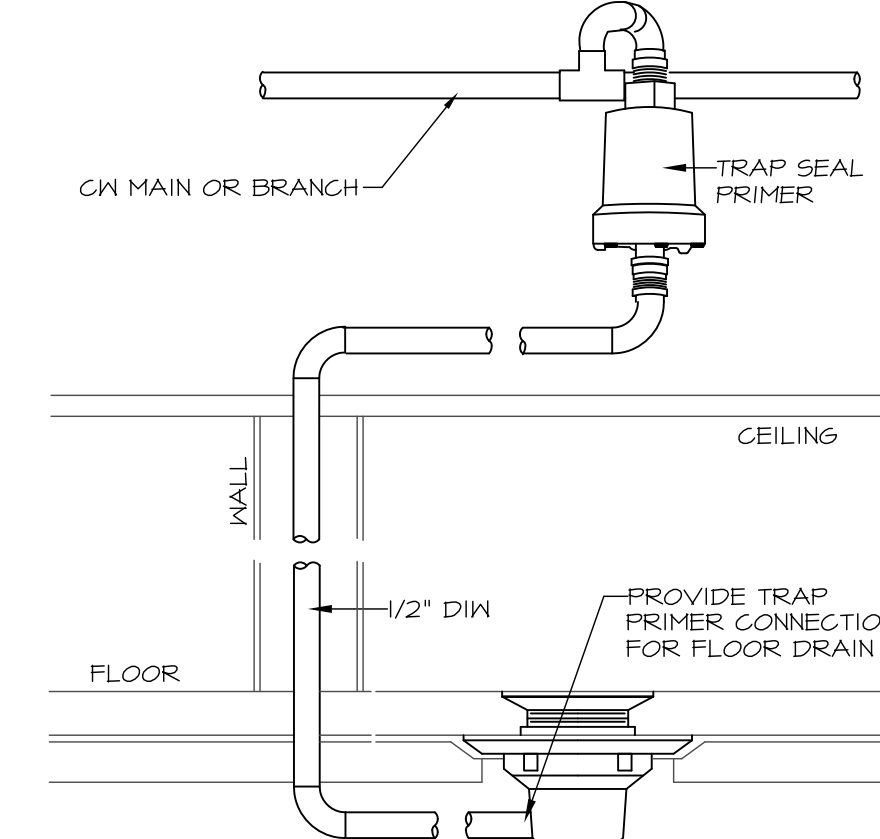

3 TP-1 TRAP SEAL PRIMER DETAIL
 TYP SCALE: NONE

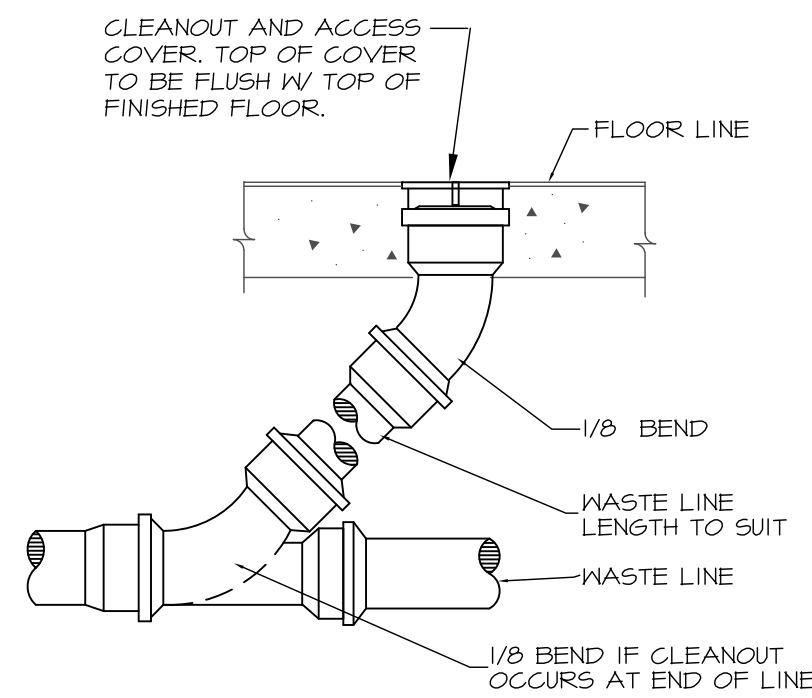

4 FLOOR CLEAN OUT DETAIL
 TYP SCALE: NONE

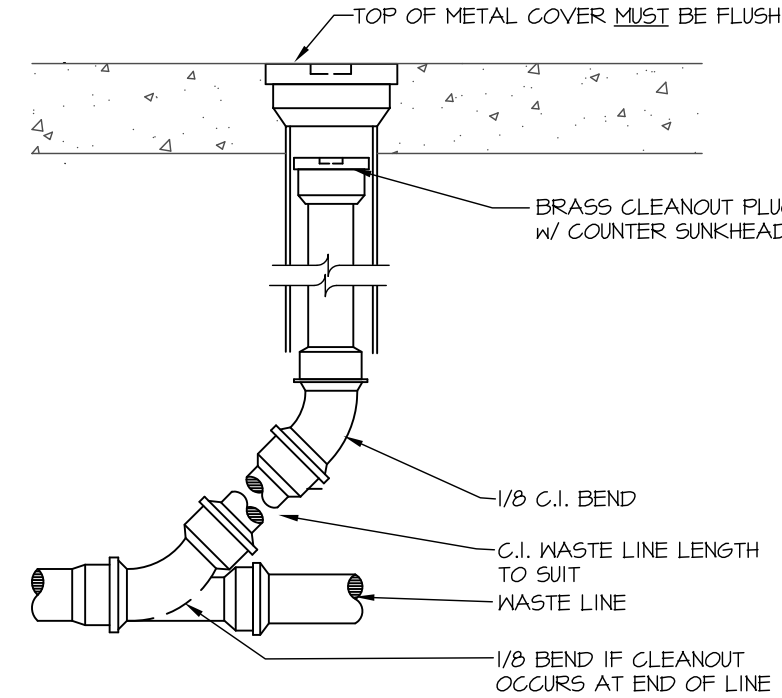

5 GARAGE CLEANOUT TO GRADE DETAIL
 TYP SCALE: NONE

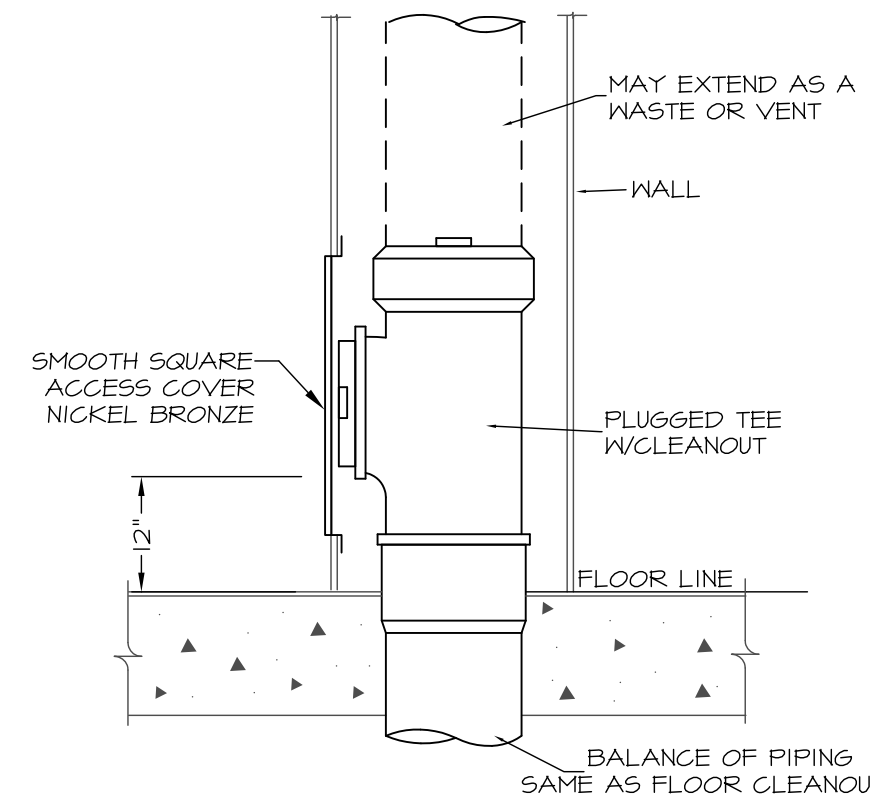

6 WALL CLEAN OUT DETAIL
 TYP SCALE: NONE

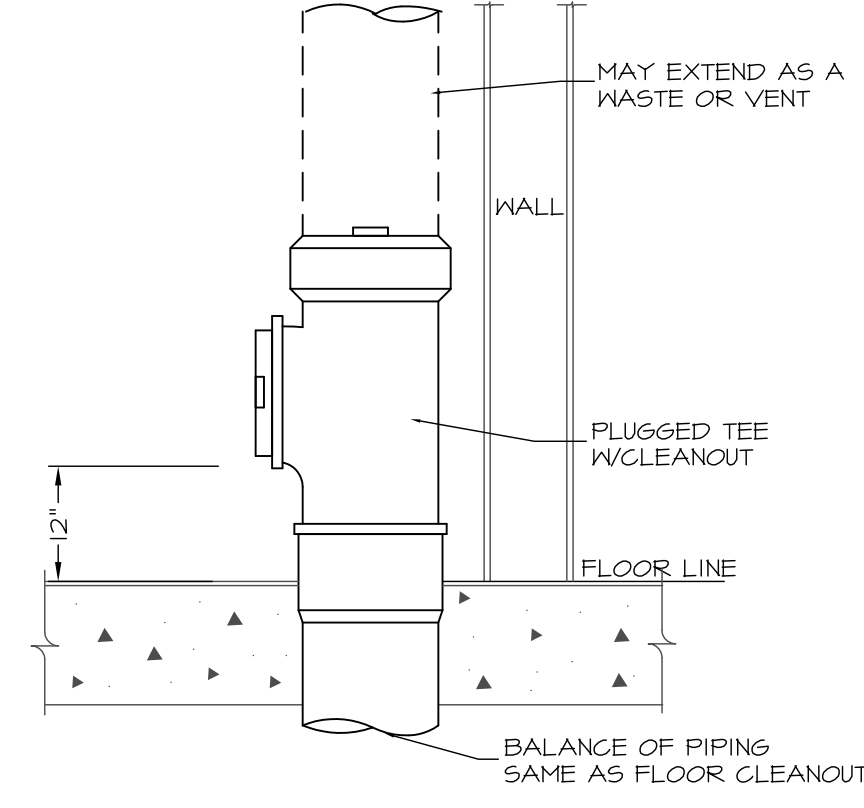

7 EXPOSED CLEAN OUT DETAIL
 TYP SCALE: NONE

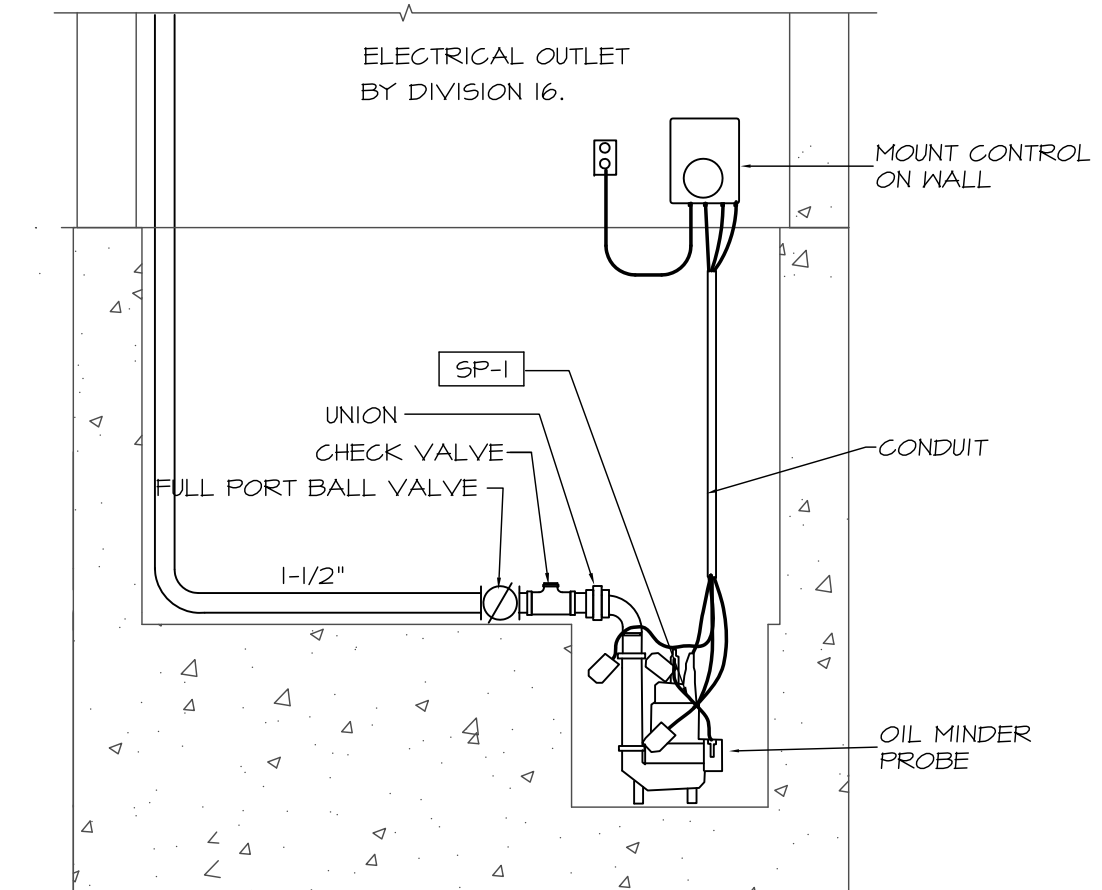

8 ELEVATOR SUMP PUMP DETAIL
 P2 SCALE: NONE

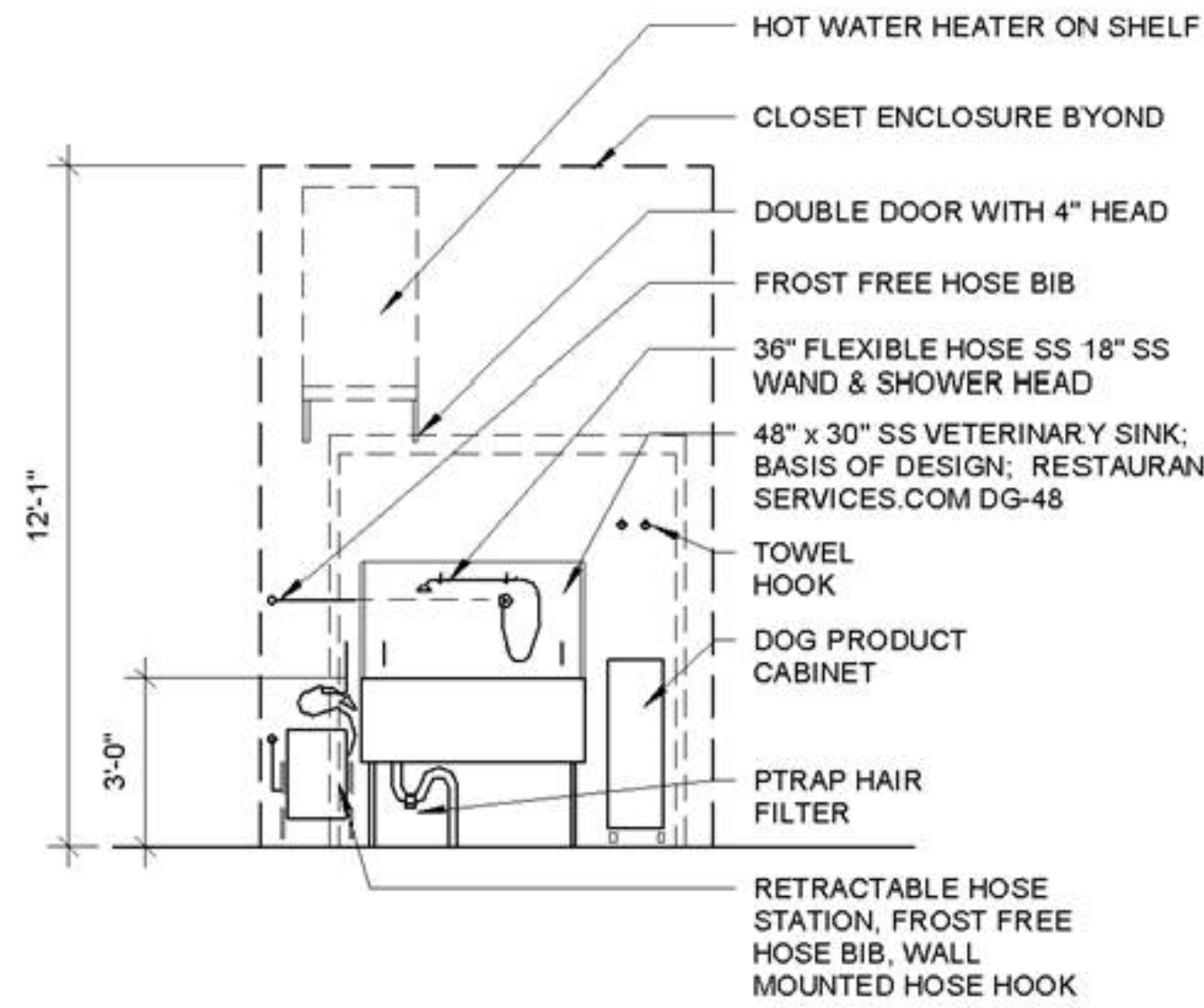

9 DOG WASH ELEVATION
 P2 SCALE: NONE

Prepared For: 118 on Munjoy Hill, LLC 118 CONGRESS STREET PORTLAND, ME 04101	Consulting Engineer: MECHANICAL SYSTEMS ENGINEERS PROJECT #10 10 FOREST FALLS DRIVE #10 YARMOUTH, MAINE 04096 (207) 846-1411 © copyright 2014
Project: 118 ON MUNJOY HILL 118 CONGRESS STREET PORTLAND, MAINE	Architect: ARCHETYPE architects 48 Union Wharf Portland, Maine 04101 (207) 772-6022 Fax (207) 772-4056
Revisions: 100% CONSTRUCTION DOCUMENTS	Date: 24 FEB 2014 Scale: NONE
PLUMBING DETAILS	
<h1>P11</h1>	
<small>MSE PROJECT 1332</small>	