

City of Portland, Maine - Building or Use Permit Application

389 Congress Street, 04101 Tel: (207) 874-8703, Fax: (207) 874-8716

Permit No: 06-1692	Issue Date:	CBL: 016 C018001
-----------------------	-------------	---------------------

Location of Construction: 23 Atlantic St	Owner Name: Dipietrantonio Ann M	Owner Address: 23 Atlantic St	Phone:
Business Name:	Contractor Name: Seth Dipietrantonio	Contractor Address: 4 Picnic Hill Freeport	Phone 2075224567
Lessee/Buyer's Name	Phone:	Permit Type: Amendment to Single Family	Zone: R6

Past Use: Single Family	Proposed Use: Single Family Amend permit # 05-1138 Change floor of existing shed to wood on sauna ^{sauna} tubes	Permit Fee: \$30.00	Cost of Work: \$30.00	CEO District: 1
		FIRE DEPT: <input type="checkbox"/> Approved <input type="checkbox"/> Denied	INSPECTION: Use Group: Type:	

Proposed Project Description: Change floor of existing shed to wood on sauna ^{sauna} tubes	Signature:	Signature:
PEDESTRIAN ACTIVITIES DISTRICT (P.A.D.)		
Action: <input type="checkbox"/> Approved <input type="checkbox"/> Approved w/Conditions <input type="checkbox"/> Denied		
Signature:	Date:	

Permit Taken By: dmartin	Date Applied For: 11/20/2006	Zoning Approval	
-----------------------------	---------------------------------	------------------------	--

<ol style="list-style-type: none"> This permit application does not preclude the Applicant(s) from meeting applicable State and Federal Rules. Building permits do not include plumbing, septic or electrical work. Building permits are void if work is not started within six (6) months of the date of issuance. False information may invalidate a building permit and stop all work.. 	Special Zone or Reviews <input type="checkbox"/> Shoreland <input type="checkbox"/> Wetland <input type="checkbox"/> Flood Zone <input type="checkbox"/> Subdivision <input type="checkbox"/> Site Plan Maj <input type="checkbox"/> Minor <input type="checkbox"/> MM <input type="checkbox"/> Date: 11/27/06 <i>Ann</i>	Zoning Appeal <input type="checkbox"/> Variance <input type="checkbox"/> Miscellaneous <input type="checkbox"/> Conditional Use <input type="checkbox"/> Interpretation <input type="checkbox"/> Approved <input type="checkbox"/> Denied Date:	Historic Preservation <input checked="" type="checkbox"/> Not in District or Landmark <input type="checkbox"/> Does Not Require Review <input type="checkbox"/> Requires Review <input type="checkbox"/> Approved <input type="checkbox"/> Approved w/Conditions <input type="checkbox"/> Denied <i>Ann</i> Date:
---	---	---	--

WITHDRAW

CERTIFICATION

I hereby certify that I am the owner of record of the named property, or that the proposed work is authorized by the owner of record and that I have been authorized by the owner to make this application as his authorized agent and I agree to conform to all applicable laws of this jurisdiction. In addition, if a permit for work described in the application is issued, I certify that the code official's authorized representative shall have the authority to enter all areas covered by such permit at any reasonable hour to enforce the provision of the code(s) applicable to such permit.

SIGNATURE OF APPLICANT ADDRESS DATE PHONE

RESPONSIBLE PERSON IN CHARGE OF WORK, TITLE DATE PHONE



General Building Permit Application

If you or the property owner owes real estate or personal property taxes or user charges on any property within the City, payment arrangements must be made before permits of any kind are accepted.

Location/Address of Construction: <u>23 Atlantic</u>		
Total Square Footage of Proposed Structure		Square Footage of Lot
Tax Assessor's Chart, Block & Lot Chart# Block# Lot# <u>016</u> <u>C</u> <u>018</u>		Owner: <u>Selvino & Annina</u> <u>23 Atlantic St</u> <u>Portland, ME</u>
Lessee/Buyer's Name (If Applicable)		Telephone: <u>879-5950</u>
Applicant name, address & telephone:		Cost Of Work: \$ <u>4</u>
		Fee: \$ <u>30</u>
		C of O Fee: \$ _____
Current Specific use: <u>Single Family</u>		
If vacant, what was the previous use? _____		
Proposed Specific use: _____		
Project description: <u>Amendment to permit # 051138</u> <u>Rather than the slab described in Section AA, I would like to build a</u> <u>wood floor system on sauna tubes. The floor will have 6x6 on the tubes w/ 2x10</u> <u>space 12.5 o.c. on the 6x6's w/ 5/8 advantage on the 2x10's</u>		
Contractor's name, address & telephone: <u>Seth DiPietrantonio 4 Picnic Hill Freeport</u> <u>865-3171 Peter or Seth</u>		
Who should we contact when the permit is ready: _____		Phone: <u>865-3171</u>
Mailing address: _____		

Please submit all of the information outlined in the Commercial Application Checklist.
Failure to do so will result in the automatic denial of your permit.

In order to be sure the City fully understands the full scope of the project, the Planning and Development Department may request additional information prior to the issuance of a permit. For further information visit us on-line at www.portlandmaine.gov, stop by the Building Inspections office, room 315 City Hall or call 874-8703.

I hereby certify that I am the Owner of record of the named property, or that the owner of record authorizes the proposed work and that I have been authorized by the owner to make this application as his/her authorized agent. I agree to conform to all applicable laws of this jurisdiction. In addition, if a permit for work described in this application is issued, I certify that the Code Official's authorized representative shall have the authority to enter all areas covered by this permit at any reasonable hour to enforce the provisions of the codes applicable to this permit.

Signature of applicant: <u>Seth DiPietrantonio</u>	Date: <u>11-20-06</u>
--	-----------------------

This is not a permit; you may not commence ANY work until the permit is issued.

WITHDRAW

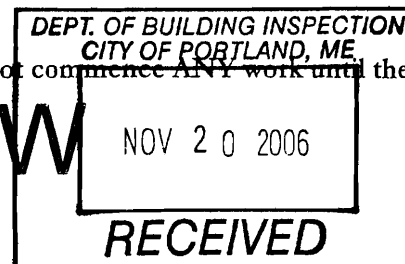

1/4" = 1'0"

SLAB PLAN

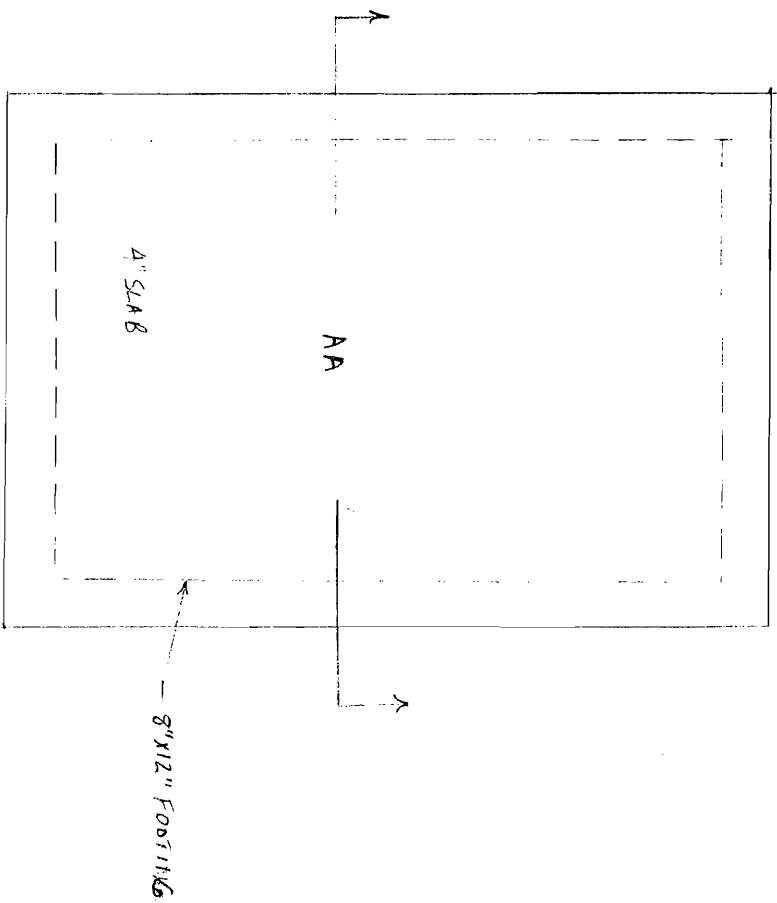

SLAB SECTION

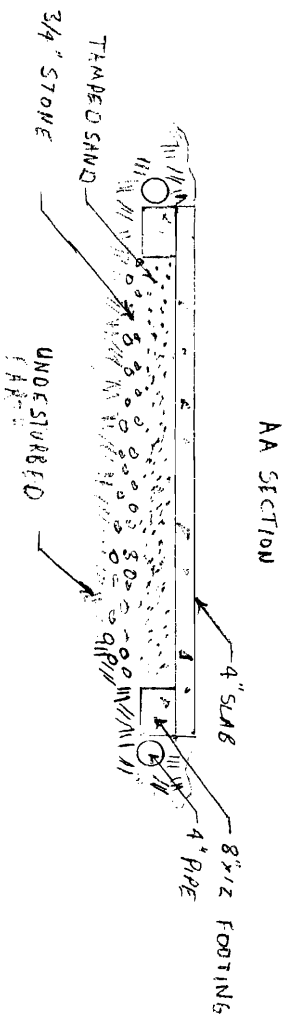

11'0" x 16'0" SHED
16" O.C. 2x4 FRAMING
4-2x8 DOOR HEADER
DOOR R.O. 8'0" x 6'0"
TRIM 2x6 PINE

2x4 Rafters - 6'-4"
Max Spacing for S

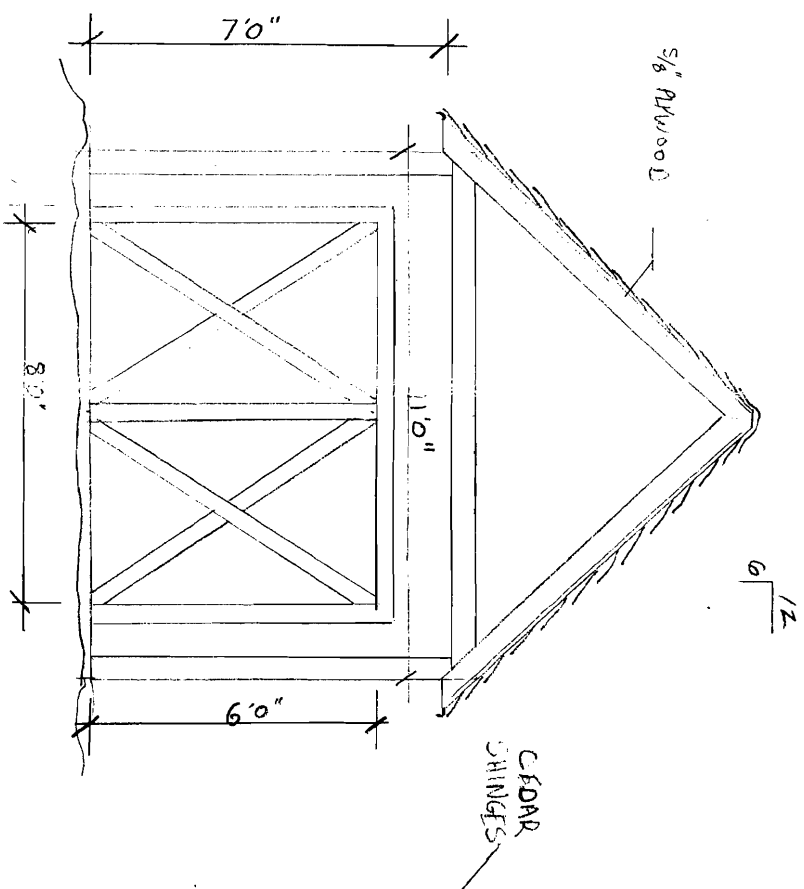

1. OVER HANG
2 5/8 plywood
3 Plywood
4 3/4" batts