

Job Name: _____
 System Reference: _____ Date: _____

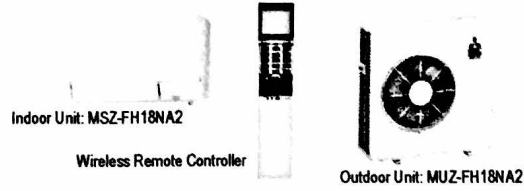

Electrical Power Requirements	208 / 230V, 1-Phase, 60 Hz
-------------------------------	----------------------------

Minimum Circuit Ampacity (MCA)		
Indoor / Outdoor	A	1 / 16

Indoor Unit		
Blower Motor (ECM)	FLA.	0.67
Blower Motor Output	W	30
SHF / Moisture Removal		0.69 / 4.8 pt./h
Field Drainpipe Size O.D.	In.(mm)	5/8 (15)

Outdoor Unit		
Compressor		DC INVERTER-driven Twin Rotary
Fan Motor (ECM)	FLA.	0.93

Airflow Rate (Lo - Med - Hi - Super Hi - Powerful)			
Indoor (Cooling)	DRY	CFM	225-262-304-355-459
	WET		194-225-261-305-395
Indoor (Heating)	DRY		201-254-317-394-514
Outdoor			1,692 / 1,634

Sound Pressure Level (Lo - Med - Hi - Super Hi - Powerful)			
Indoor	Cooling	dB(A)	27-31-35-39-47
	Heating		25-29-34-39-46
Outdoor	Cooling		52
	Heating		55

External Dimensions		
Indoor (H x W x D)	In.(mm)	12 + 11/16 x 36-7/16 x 9-3/16 (305 +17 x 925 x 234)
Outdoor (H x W x D)		34-5/8 x 33-1/16 x 13 (880 x 840 x 330)

Net Weight		
Indoor	Lbs.(kg)	29 (12)
Outdoor		124 (56)

External Finish	
Indoor	Munsell 1.0Y 9.2 / 0.2
Outdoor	Munsell No. 3Y 7.8 / 1.1

Refrigerant	R410A; 3 lb. 7 oz.
-------------	--------------------

Refrigerant Piping (Flared)		
Liquid (High Pressure)	In.(mm)	1/4 (6.35)
Gas (Low Pressure)		1/2 (12.7)
Max. Total Refrigerant Pipe Length (Height Diff.)	Ft. (m)	50 (15)
Max. Total Refrigerant Pipe Length (Length.)		100 (30)

ACCESSORIES:

Indoor Unit

- Condensate Pump (BlueDiamond X87-711/721; 115/230V)
- Condensate Pump (Sauermann SI30-115/230; 115/230V)
- Replacement Platinum Deodorizing Filter (MAC-3000FT-E)
- Replacement Anti-allergy Enzyme Filter (MAC-2330FT-E)

Outdoor Unit

- Air Discharge Guide (MAC-886SG-E)
- Base Pan Heater (MAC-642BH-U)
- Drain Socket (MAC-851DS)

Controls

- Wireless Controller (MHK1)
- Wired Remote Controller PAR-31MAA (Requires MAC-333IF-E)
- Wireless Interface for kumo cloud™ (PAC-WHS01WF-E)
- Thermostat Interface (PAC-US444CN-1)

SPECIFICATIONS:

Rated Conditions (Capacity / Input)		
Cooling ¹	Btu/h / W	17,200 / 1,375
Heating at 47° F ²	Btu/h / W	20,300 / 1,720

Capacity Range		Minimum	Maximum
Cooling ¹	Btu/h	6,450	21,000
Heating at 47° F ²	Btu/h	5,150	30,000
Heating at 17° F ³	Btu/h	-	20,300
Heating at 5° F ⁴	Btu/h	-	20,300

¹ Cooling | Indoor: 80° F (27° C) DB / 67° F (19° C) WB; Outdoor: 95° F (35° C) DB / 75° F (24° C) WB
² Heating at 47° F | Indoor: 70° F (21° C) DB / 60° F (16° C) WB; Outdoor: 47° F (8° C) DB / 43° F (6° C) WB
³ Heating at 17° F | Indoor: 70° F (21° C) DB / 60° F (16° C) WB; Outdoor: 17° F (-8° C) DB / 15° F (-9° C) WB
⁴ Heating at 5° F | Indoor: 70° F (21° C) DB / 60° F (16° C) WB; Outdoor: 5° F (-15° C) DB / 5° F (-15° C) WB
 * Rating Conditions per AHRI Standard.

Operating Conditions (Indoor Intake Air Temp.) (Max./ Min.)	
Cooling ⁵	90° F (32° C) DB / 67° F (19° C) DB
Heating	80° F (27° C) DB / 70° F (21° C) DB

Operating Conditions (Outdoor Intake Air Temp.) (Max./ Min.)	
Cooling ⁵	115° F (46° C) DB / 14° F (-10° C) DB
Heating	75° F (24° C) DB / -13° F (-25° C) DB**

⁵ Applications should be restricted to comfort cooling only; equipment cooling applications are not recommended for low ambient temperature conditions.
 ** System cuts out at -18° F (-28° C) to avoid thermistor error and automatically restarts at -14° F (-26° C).

AHRI Efficiency Ratings	
SEER / HSPF	21 / 12
COP at 47° F / 17° F	3.46 / 3.04

Energy Star [®]	Yes
--------------------------	-----

ENERGY STAR products are third-party certified by an EPA-recognized Certification Body.

DIMENSIONS: MSZ-FH18NA2 & MUZ-FH18NA2

MSZ-FH18NA2

Unit: inch

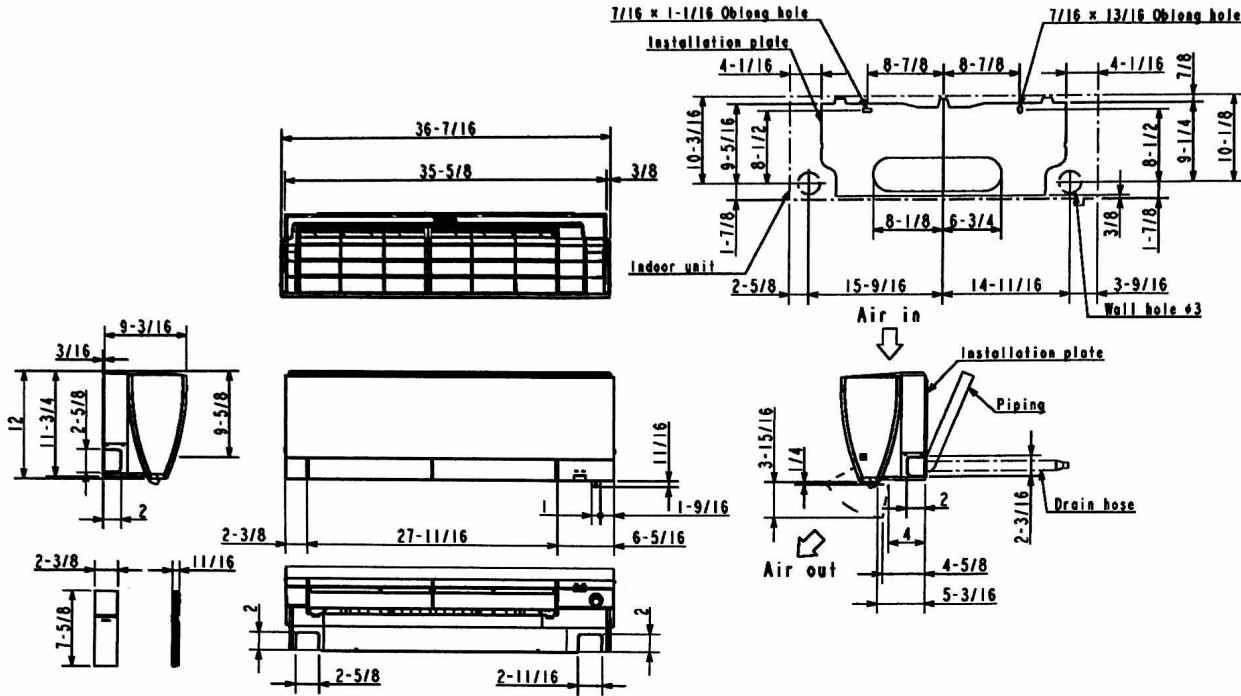

(MSZ-FH15/18NA/18NA2)

Piping	Insulation	ø1-7/16 O.D
	Liquid line	ø1/4 19-11/16 (Flared connection ø1/4)
	Gas line	ø3/8 16-15/16 (Flared connection ø1/2)
	Drain hose	Insulation ø1-1/8 Connected part ø5/8 O.D

MUZ-FH18NA2

Unit: inch

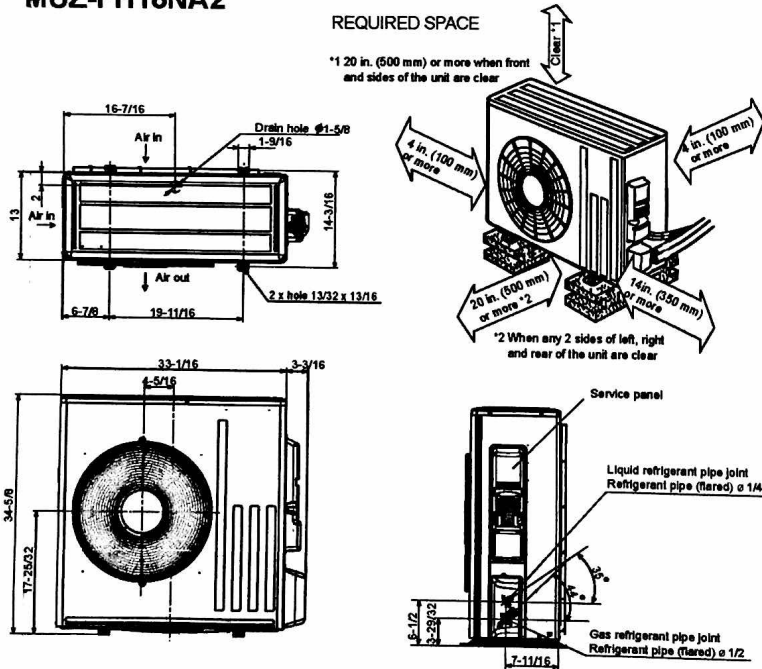

FORM# MSZ-FH18NA2 / MUZ-FH18NA2 - 201705

Specifications are subject to change without notice.



1340 Satellite Boulevard, Suwanee, GA 30024
Toll Free: 800-433-4822 www.mehvac.com

