

1. DECK TO WALL DETAIL

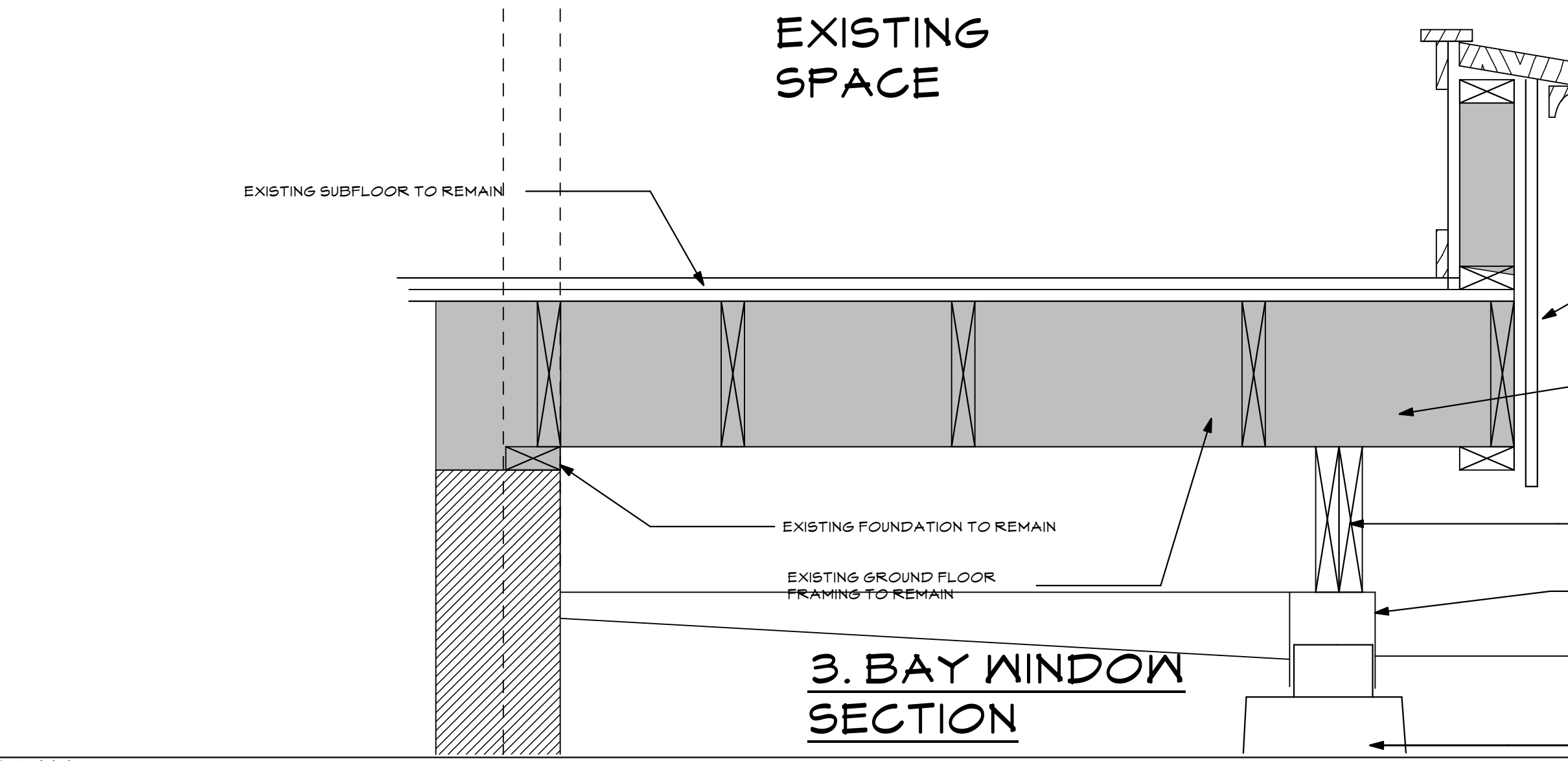

3. BAY WINDOW SECTION

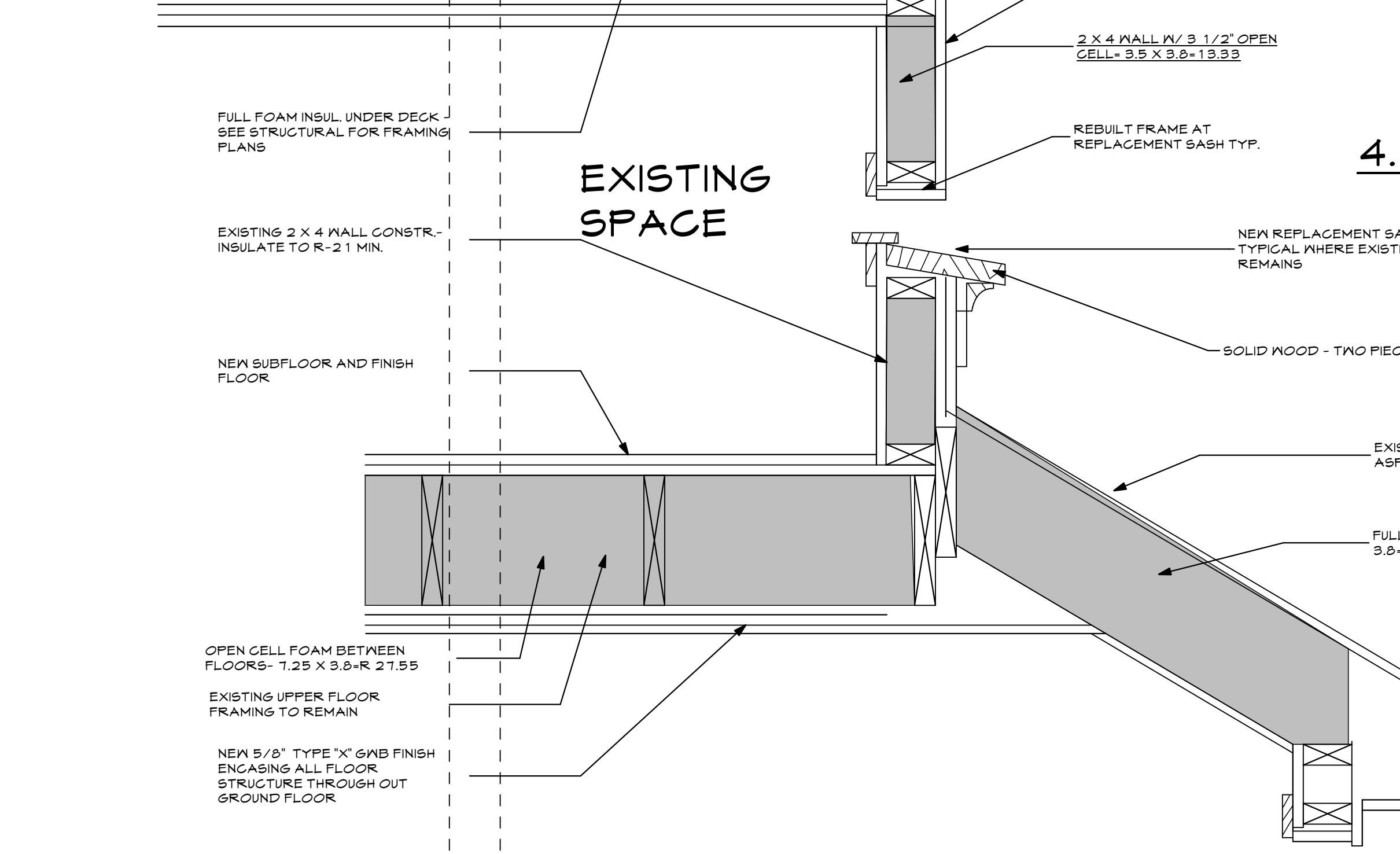
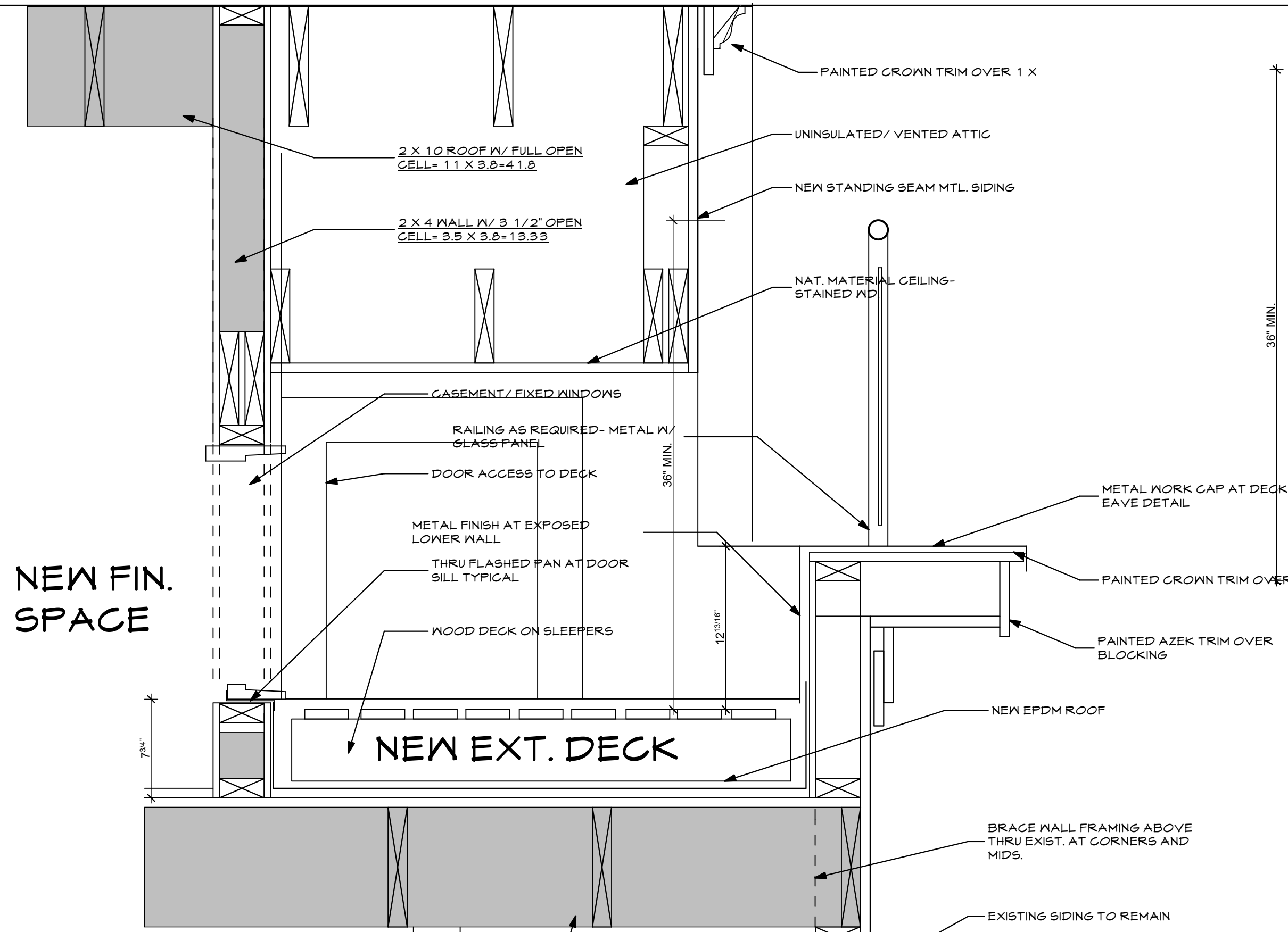
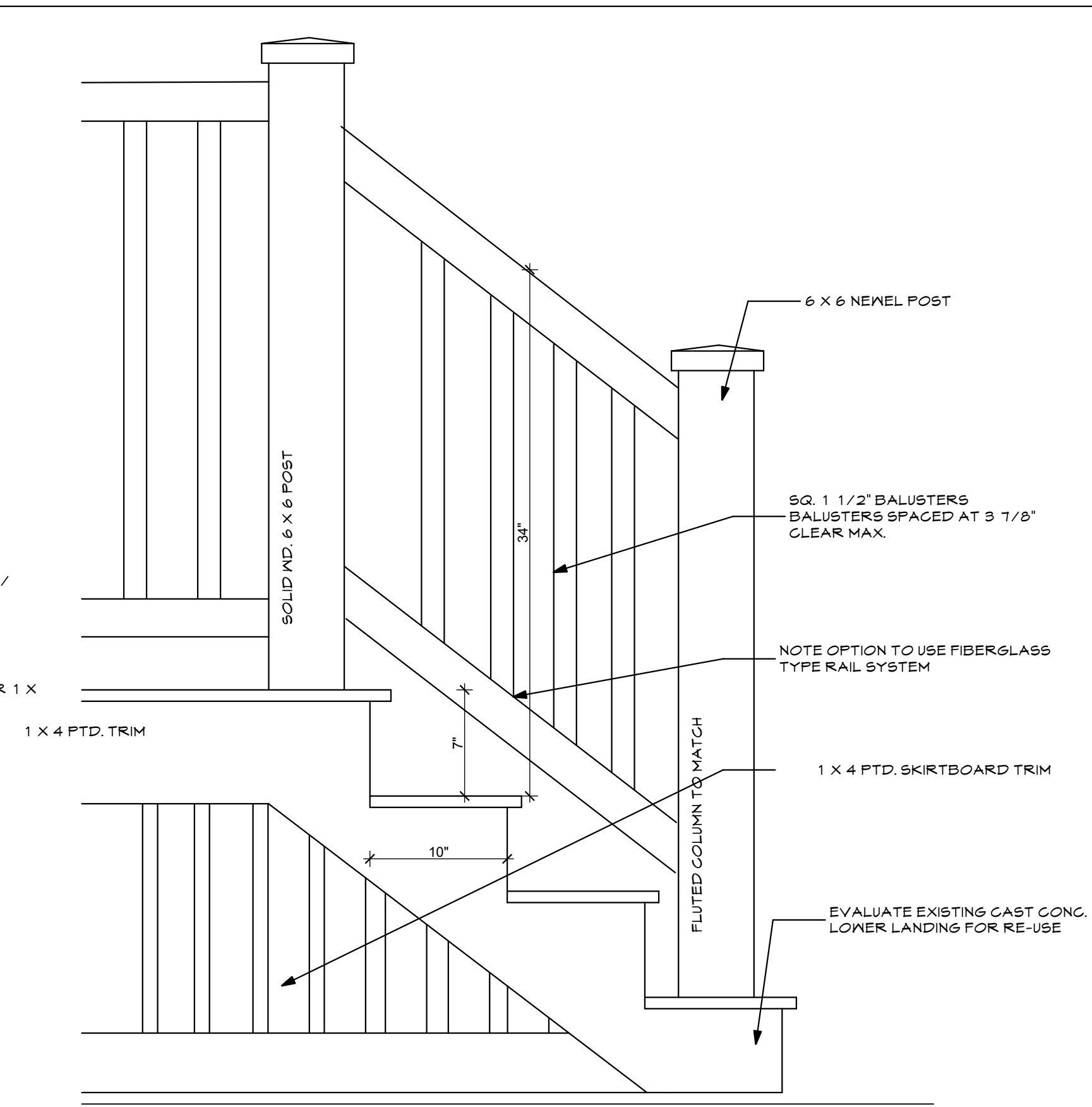

4. ENTRY PORCH STAIR SECTION

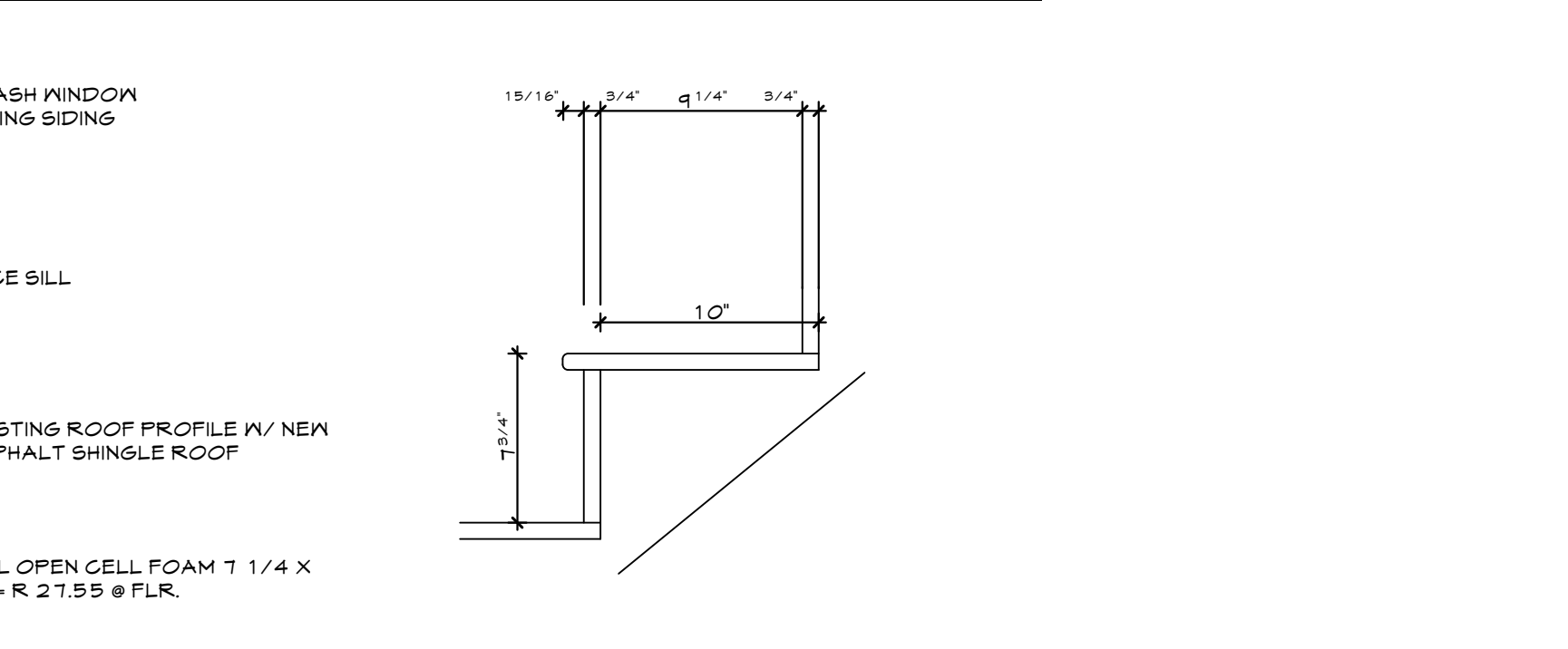

5. TYP. STAIR TREAD

32 TURNER ST.
 AQUARIUS PROPERTY MANAGEMENT
 PORTLAND, MAINE

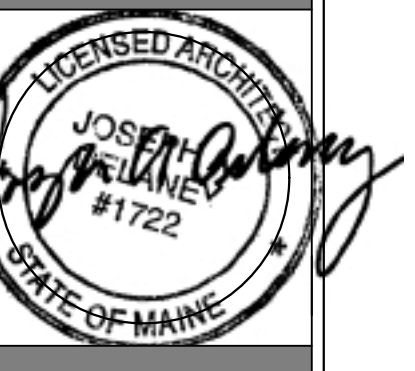

WHIPPLE — CALLENDER ARCHITECTS

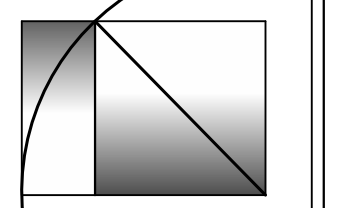

136 PLEASANT AVE.
 PORTLAND, ME 04103
 P 207.775.2646
 F 207.775.3631
 www.whipplecallender.com

MARK	DATE	DESCRIPTION

DATE: PERMIT APP. 2.12.14
 CHECKED BY: JAD
 DRAWN BY: JAD
 JOB: 13-2014
 SHEET TITLE: DETAILS

A-501