

Oct 26, 2017 - 8:27am  
 H:\Projects\2017\17078 - Done Dumond Structural Rpt Portland\Working Drawings (DWG)\17078 - STRUCTURAL PLAN.dwg Jonch

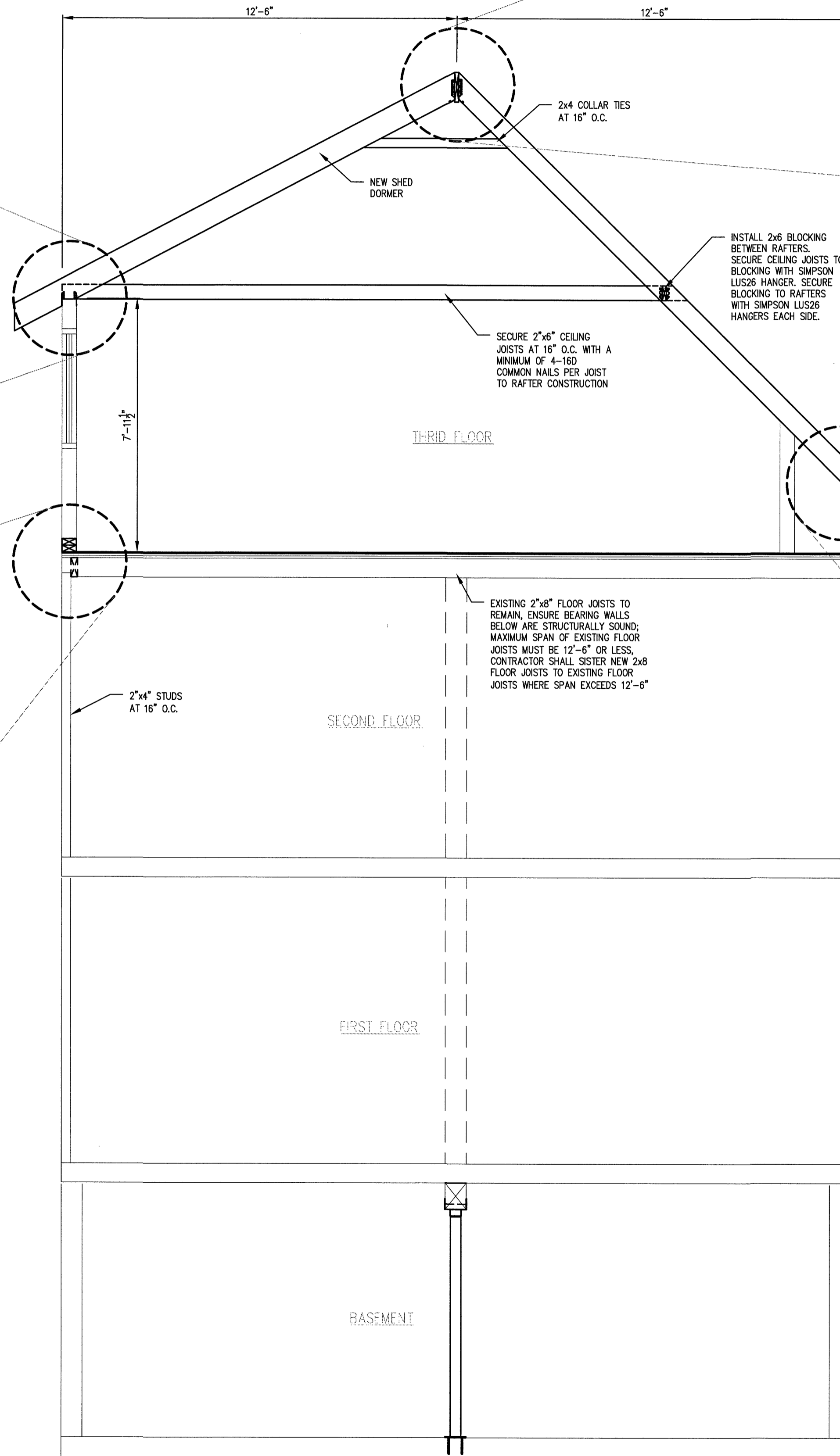

SECTION VIEW (A-A)  
 SCALE: 3/8" = 1'-0"

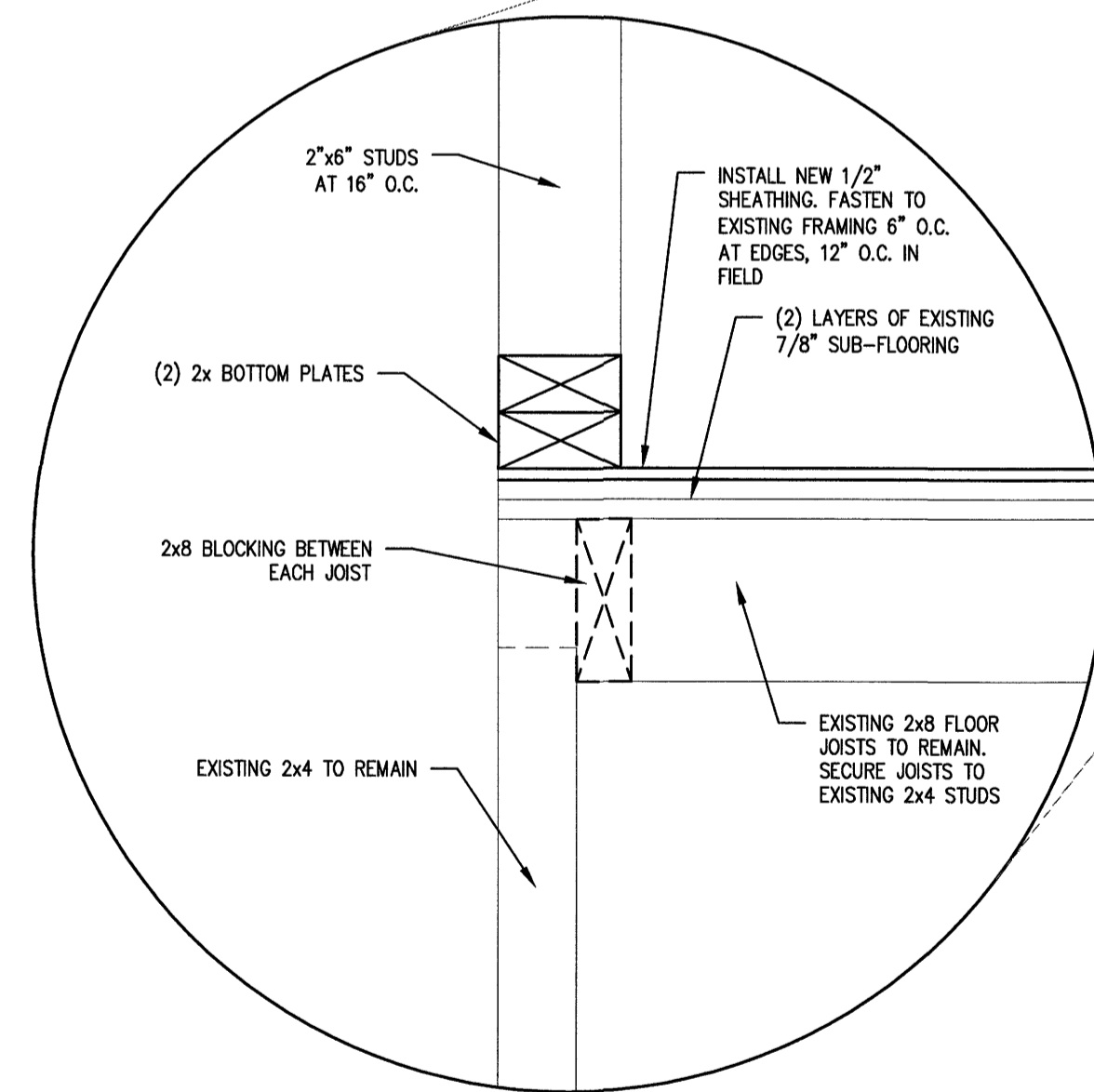
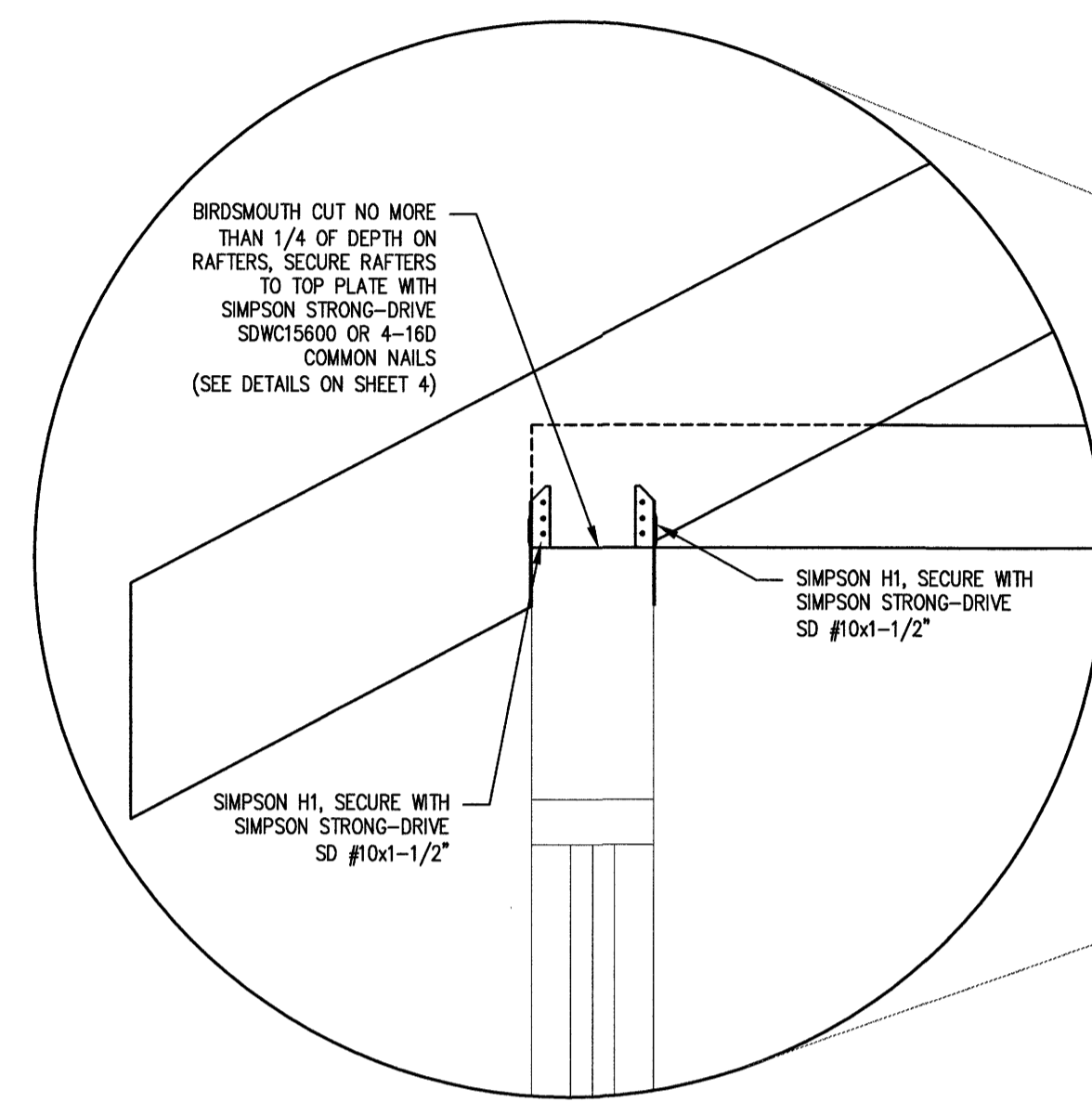
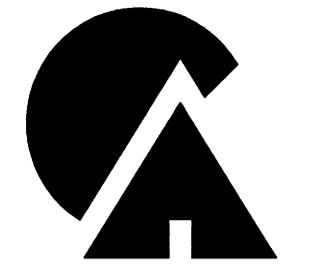
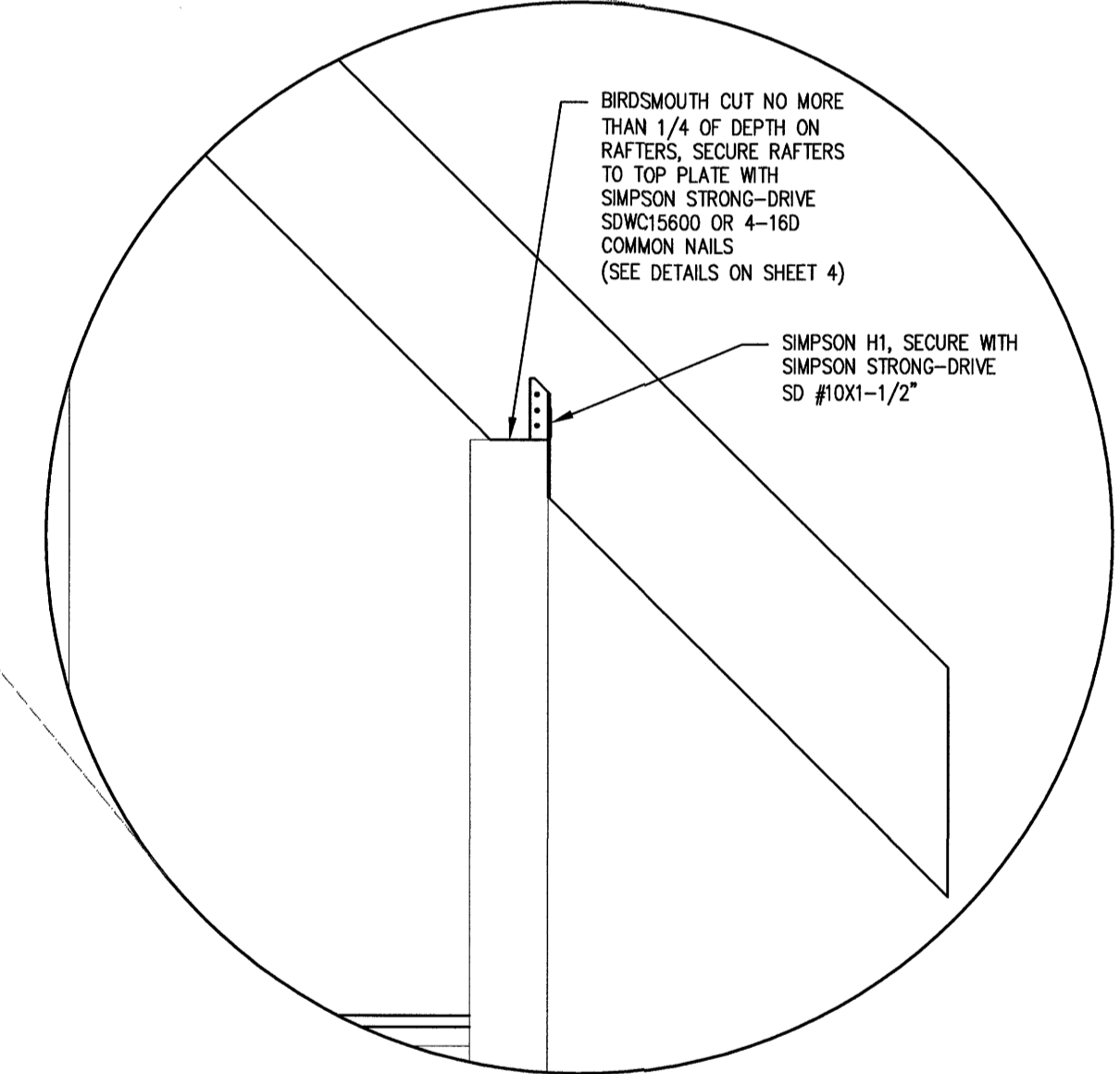
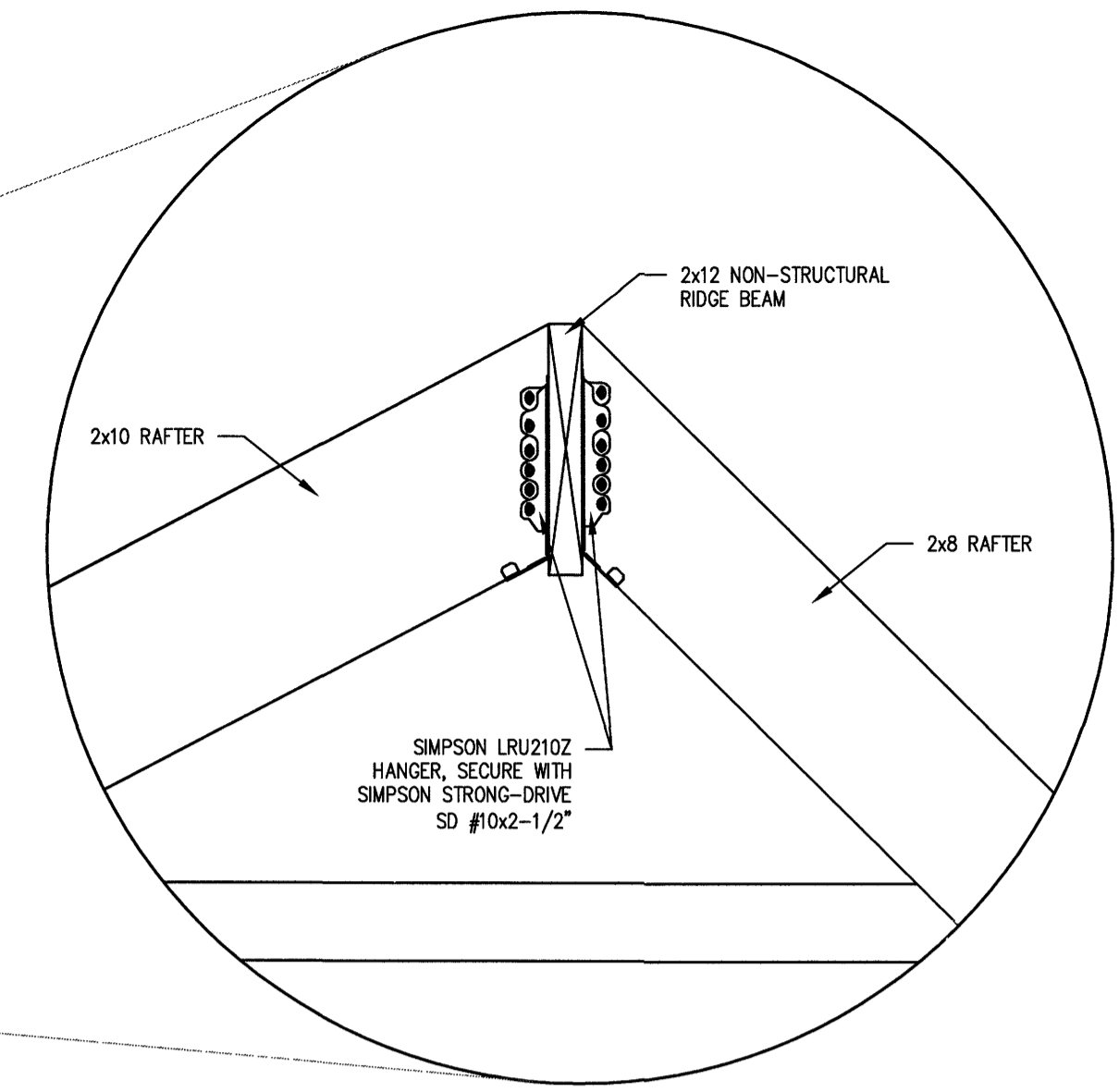

**CARPENTER ASSOCIATES**  
 CONSULTING ENGINEERS  
 687 STILLWATER AVENUE - OLD TOWN - MAINE 04468

NO.	DATE	BY	DESCRIPTION

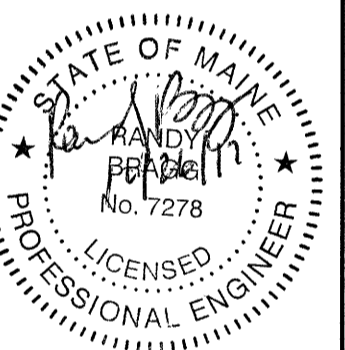

PETER DOWLING  
**DOWLING HOUSE THIRD FLOOR RENOVATION**  
 59 CONGRESS STREET - PORTLAND, MAINE  
**STRUCTURAL SECTION VIEWS**

Drawn: JE  
 Checked: RB  
 Scale: AS NOTED  
 Date: 09-29-2017  
 Project No:  
 17078  
 Sheet Number:

FOR REVIEW  
 10-26-2017

**2**