

Side Wall Vent Termination - Stainless Steel, CPVC or PP(s)

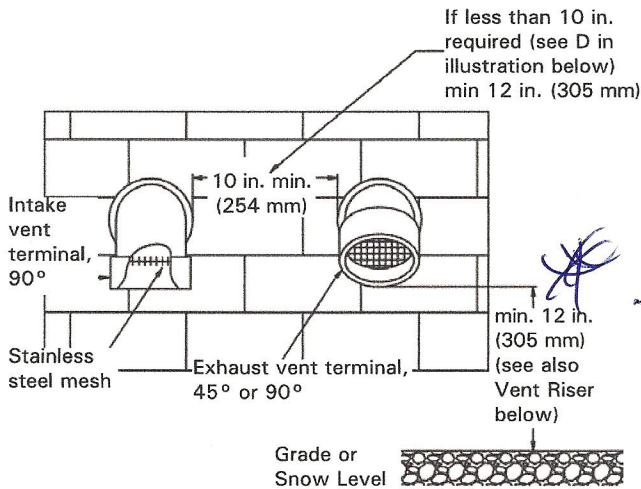

Side wall vent termination (front view)

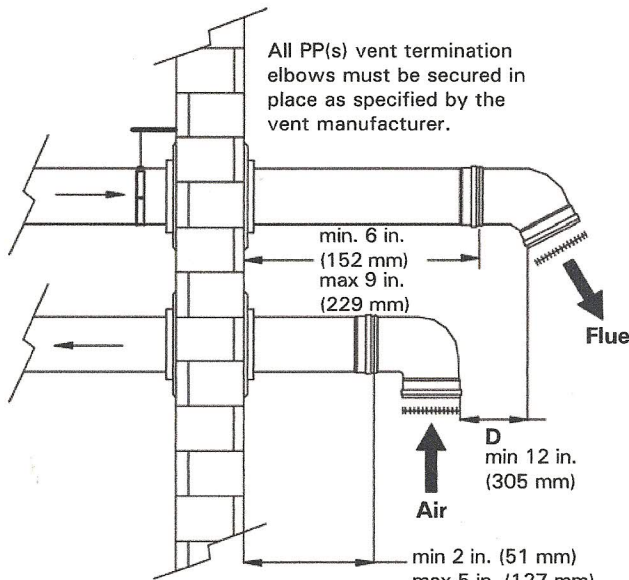

Side wall vent termination (side view)

IMPORTANT

The exhaust vent/air intake system must terminate so that proper clearances are maintained as cited in local codes or the latest edition of the "Natural Gas and Propane Installation Code" CAN/CSA-B149.1 (Canada), or the "National Fuel Gas Code" ANSI Z223.1 (NFPA 54) (U.S.A.). See page 8.

WARNING

Vent termination must be at least 12 in. (300 mm) above the anticipated snow level (consult your local building authorities or local weather office). Locate vent termination in such a way that it cannot be blocked by snow.

IMPORTANT

For PP(s) systems, all exhaust vent and air intake piping and elbows exposed outside, must be UV resistant polypropylene (supplied by the vent manufacturer).

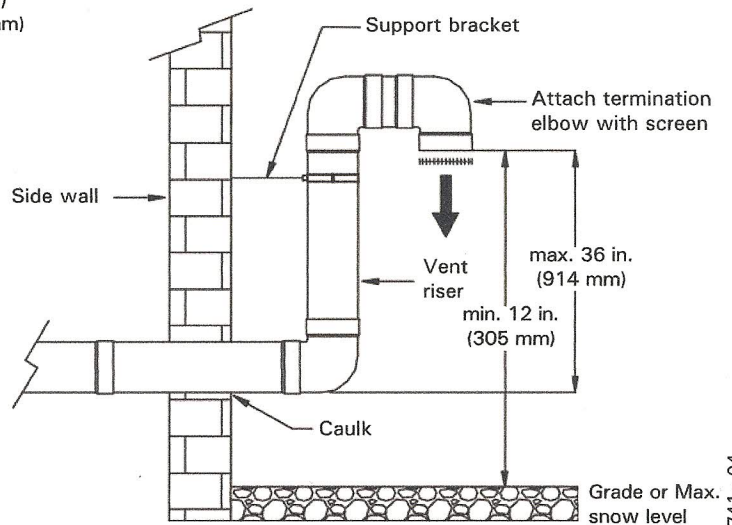

Installation of field fabricated vent riser