

BUILDING A
VERTICAL BOUNDARIES

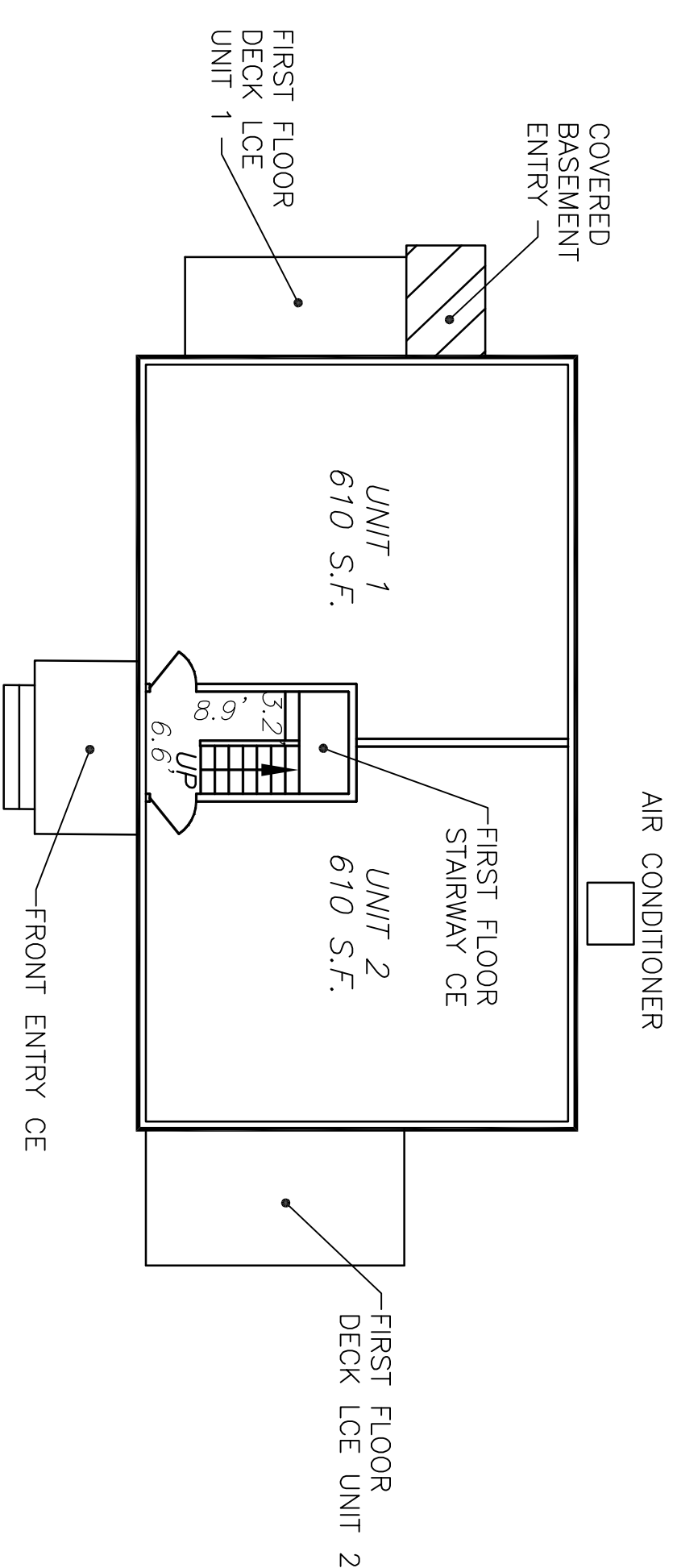

BUILDING B
VERTICAL BOUNDARIES

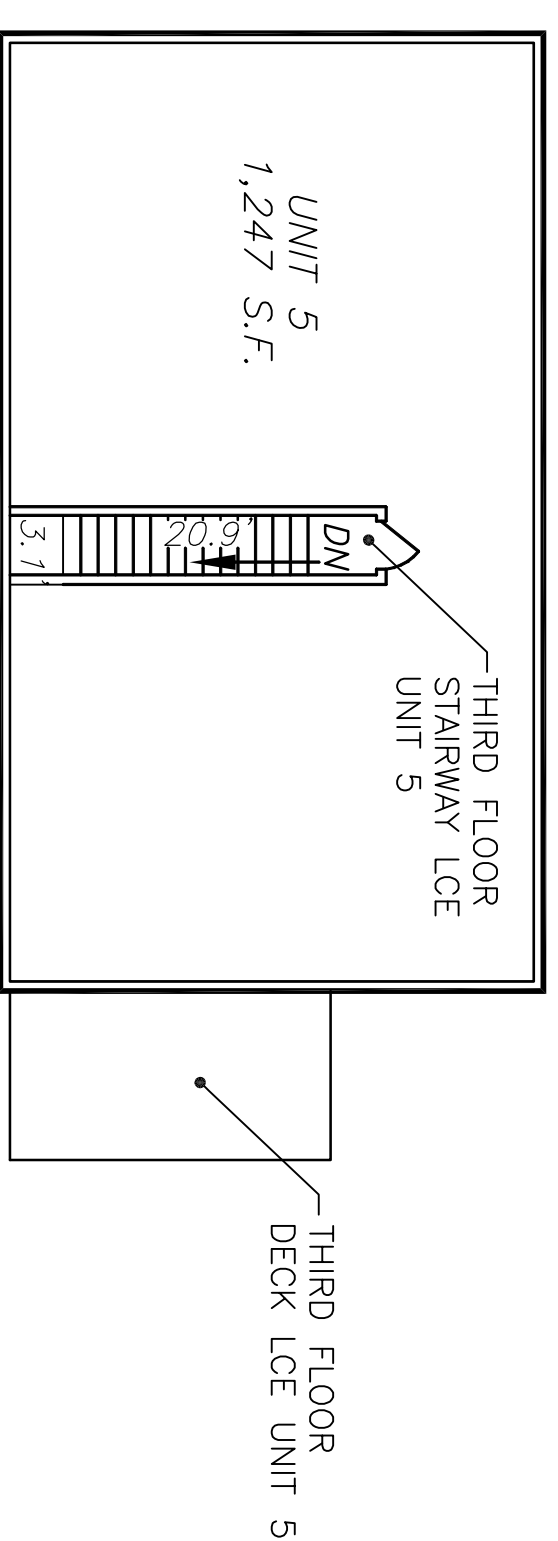
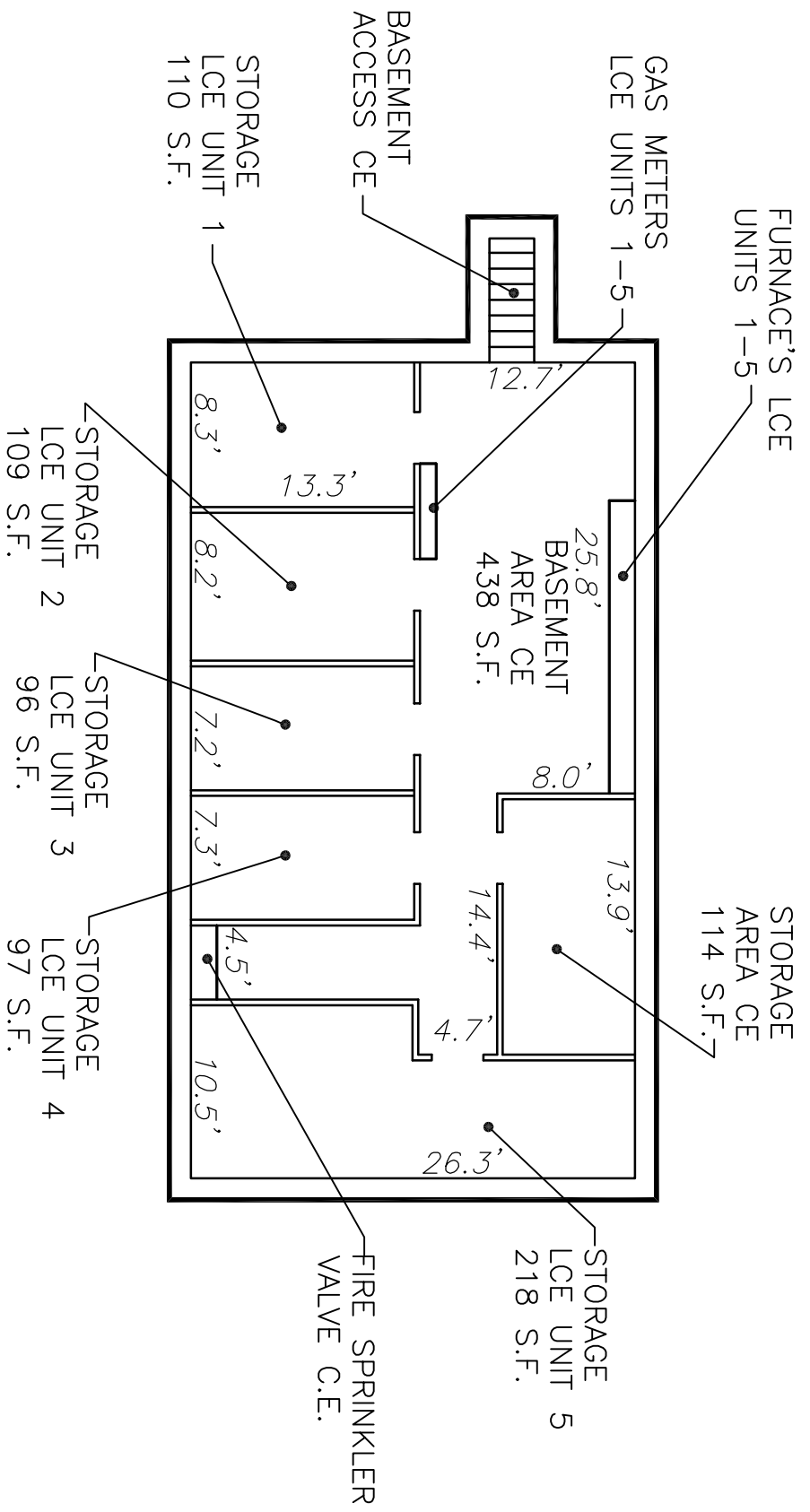
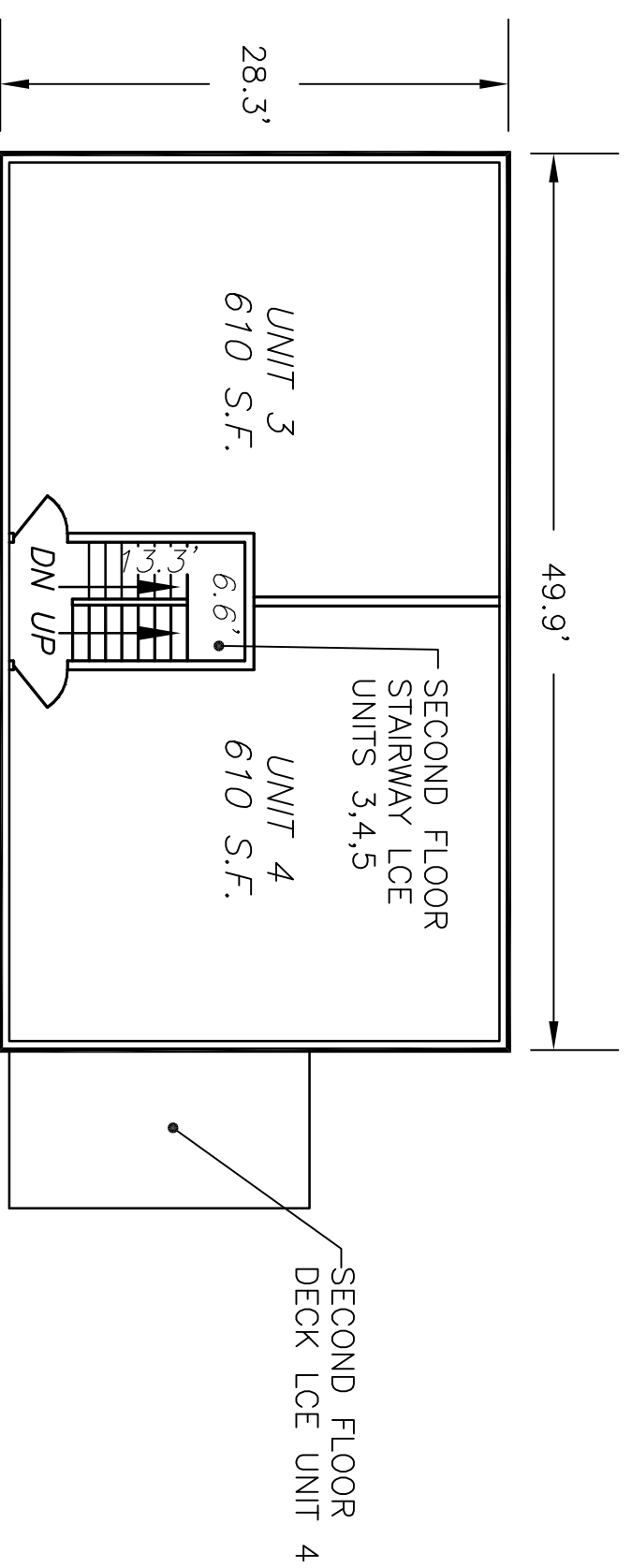
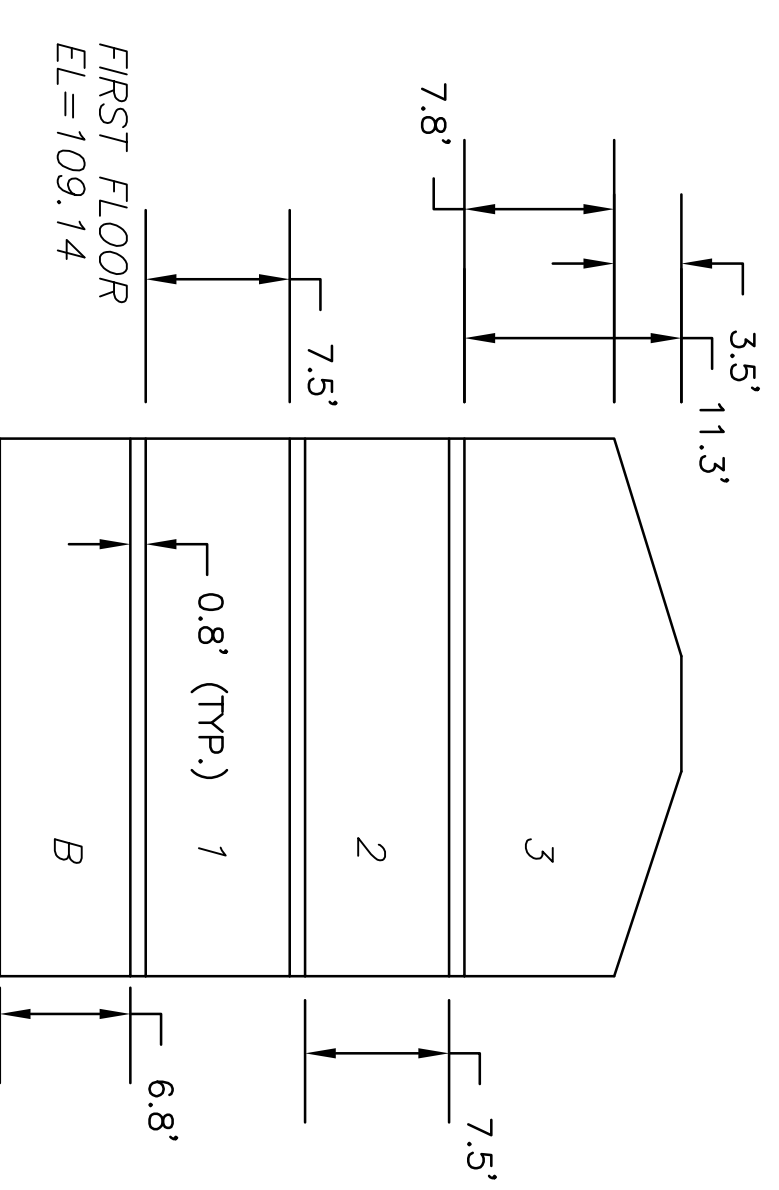
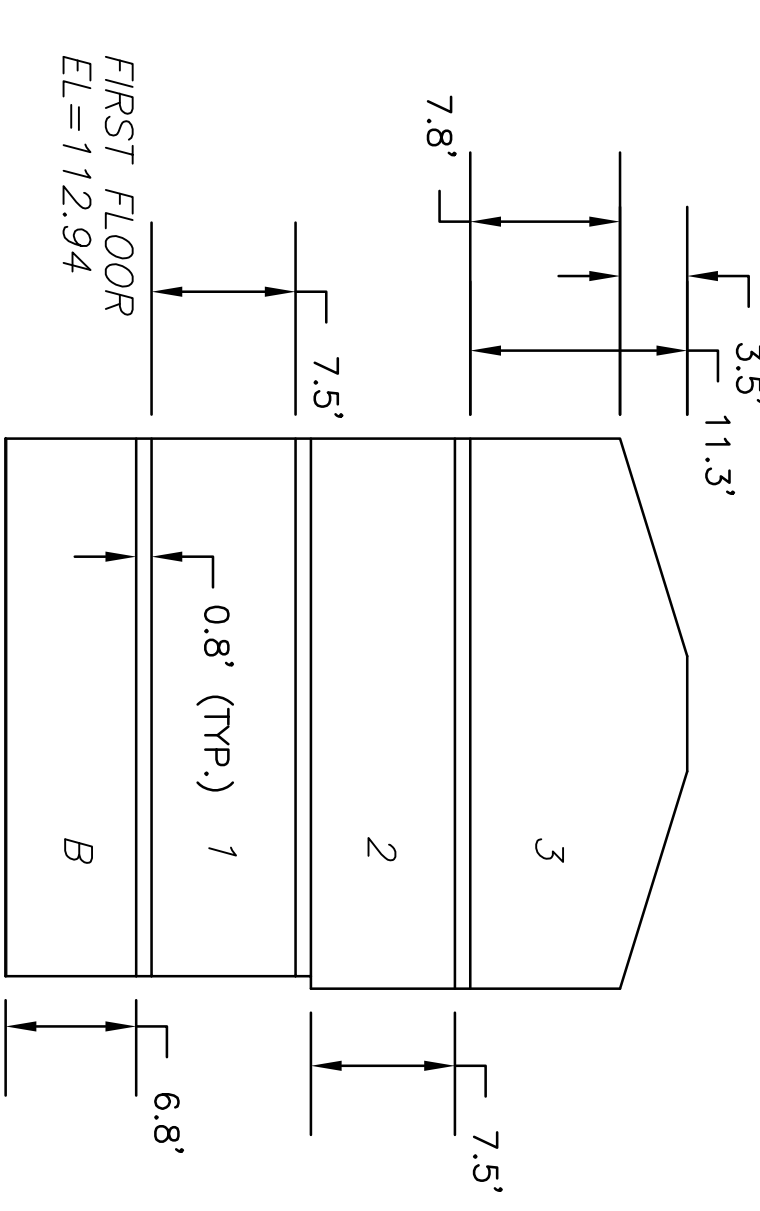

BUILDING A
END VIEW

BUILDING B
END VIEW

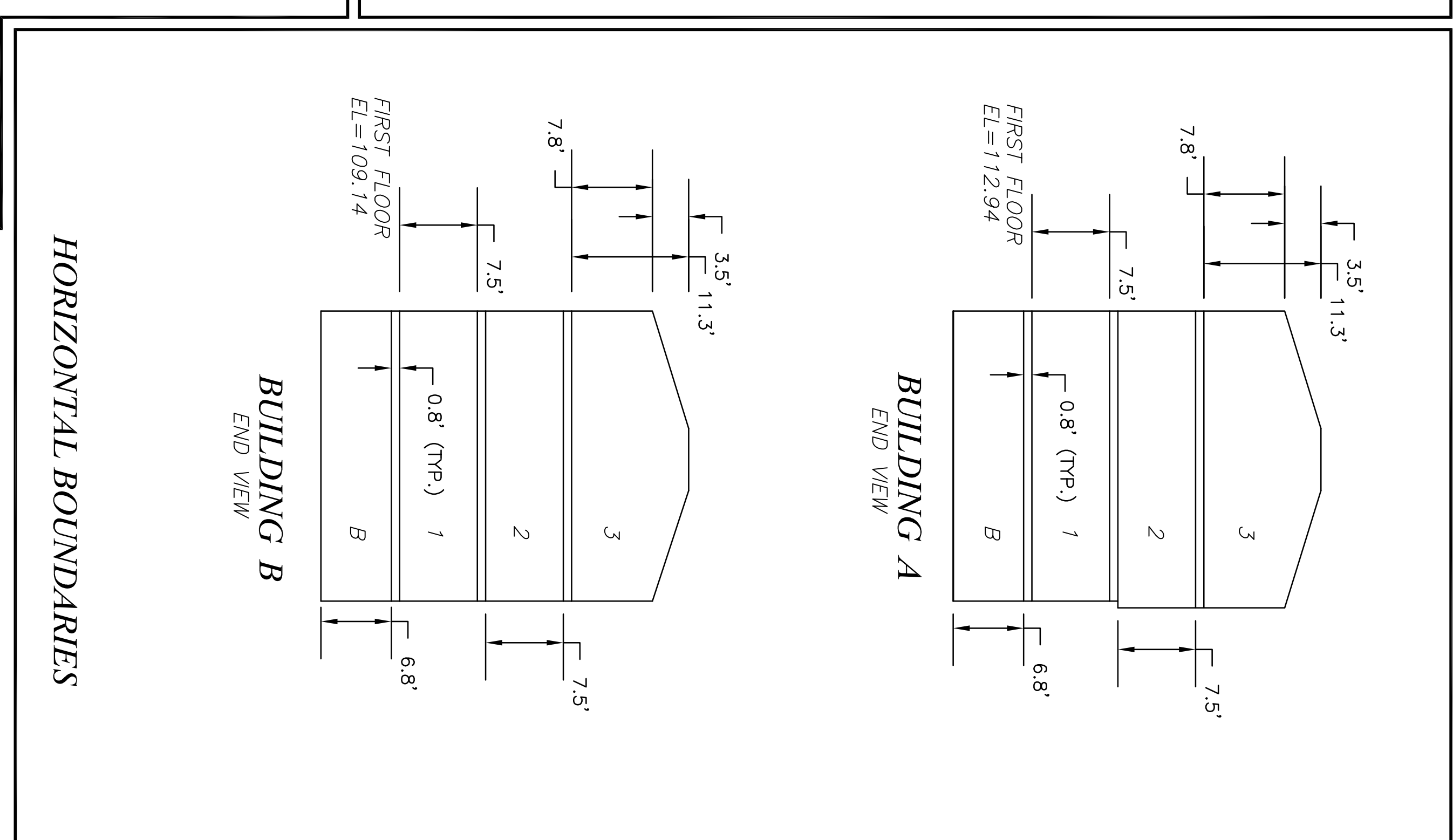

PROMENADE PLACE CONDOMINIUM
HORIZONTAL AND VERTICAL BOUNDARIES

234 & 236 EASTERN PROMENADE, PORTLAND, MAINE

Owner: **G.O. ENTERPRISES, LLC**
19 SOUTH STREET, UNIT 5, PORTLAND, MAINE 04101

Prepared for: **G.O. ENTERPRISES, LLC**
19 SOUTH STREET, UNIT 5, PORTLAND, MAINE 04101

Drawn by: **JOHANN BUISMAN**
1314

PROJECT: 27991
DATE: FEBRUARY 19, 2008
REVISION: APRIL 16, 2014
SCALE: 1" = 10'
COMMENTS: REVISED BUILDING NUMBERS

DRAWING NAME: 27991.DWG
DATE: FEBRUARY 19, 2008
SCALE: 1" = 10'

STAMP AND SIGNATURE

JOHANN BUISMAN
1314
REGISTERED PROFESSIONAL ENGINEER
NO. 1314
MAINE

Northwest Civil Solutions
SURVEYING ENGINEERING LAND PLANNING
153 US ROUTE 1, SCARBOROUGH, MAINE 04074
Tel: 207.883.1000 Fax: 207.883.1001
Email: info@northwestcivilsolutions.com
Web: www.northwestcivilsolutions.com

SHEET 2 OF 2