

**GENERAL NOTES**

- 1) Smoke detectors and sprinklers as required per code
- 2) 1 HR continuous fire rated wall assembly between units
- 3) Egress windows in bedroom as noted on plan
- 4) All insulation as required per energy code
- 5) See structural plans for all framing related information

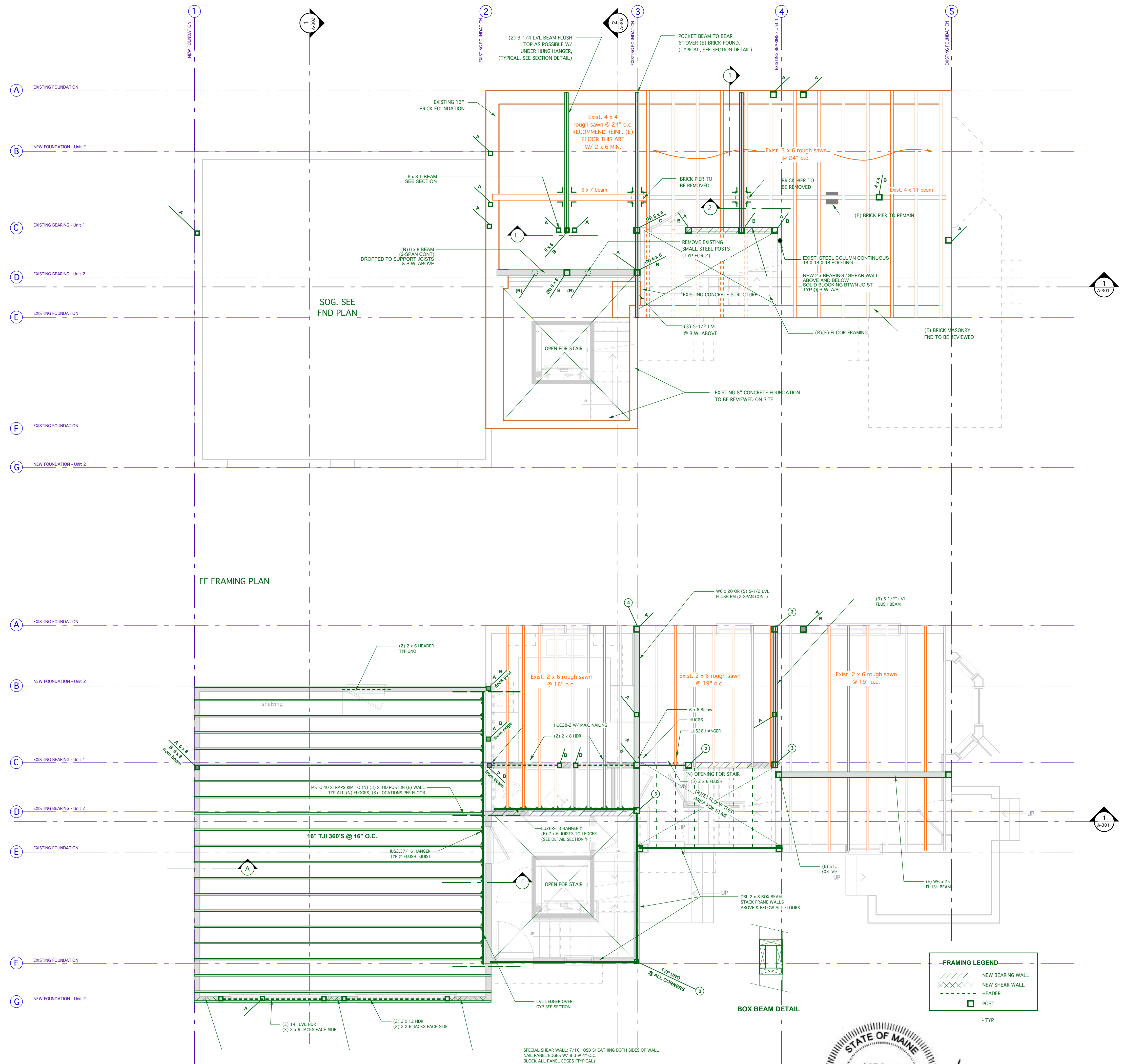

SECOND FLOOR FRAMING PLAN

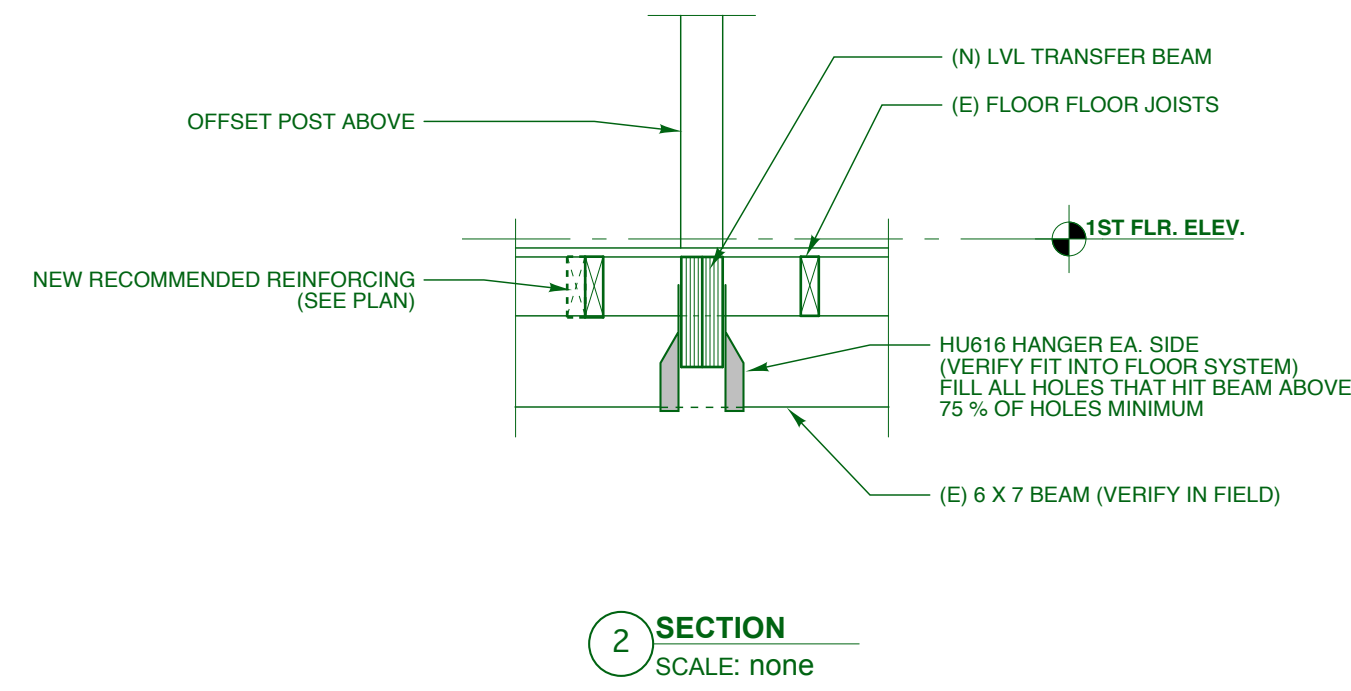
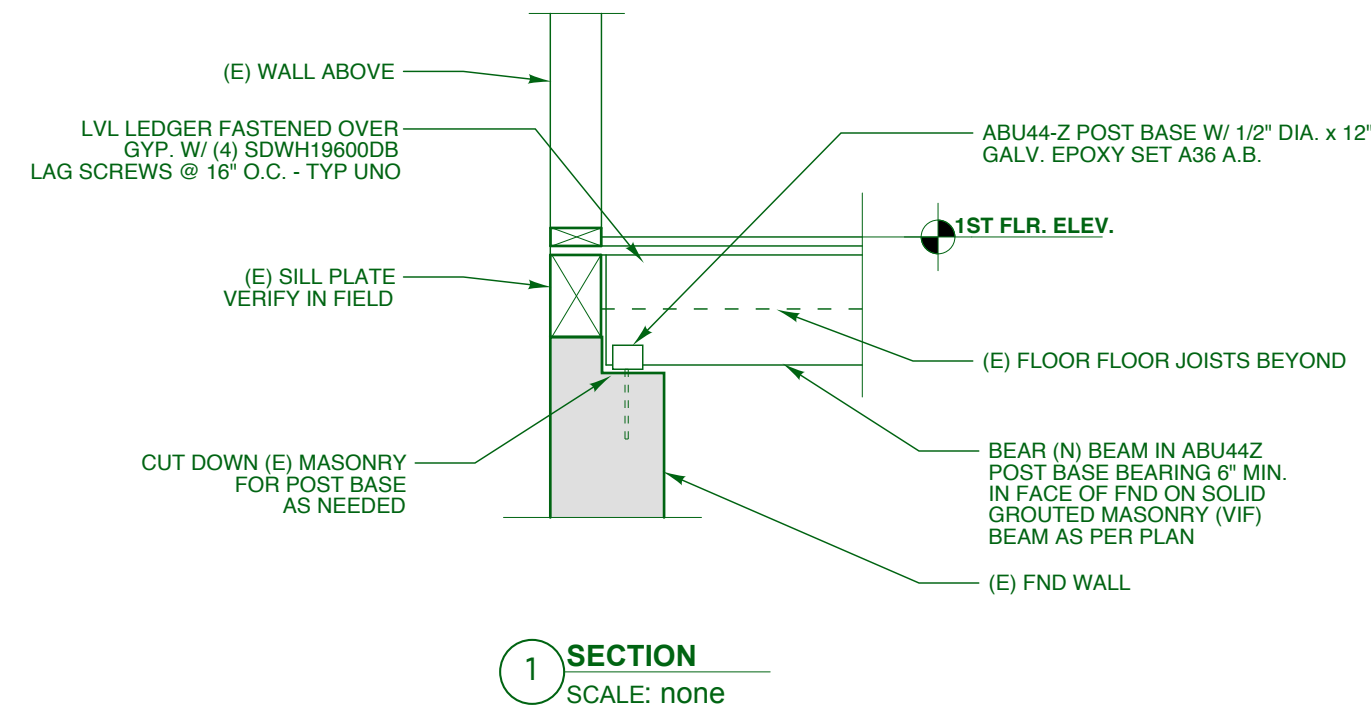