

10 Assembly - Exterior Roof Deck
3' = 1'-0"

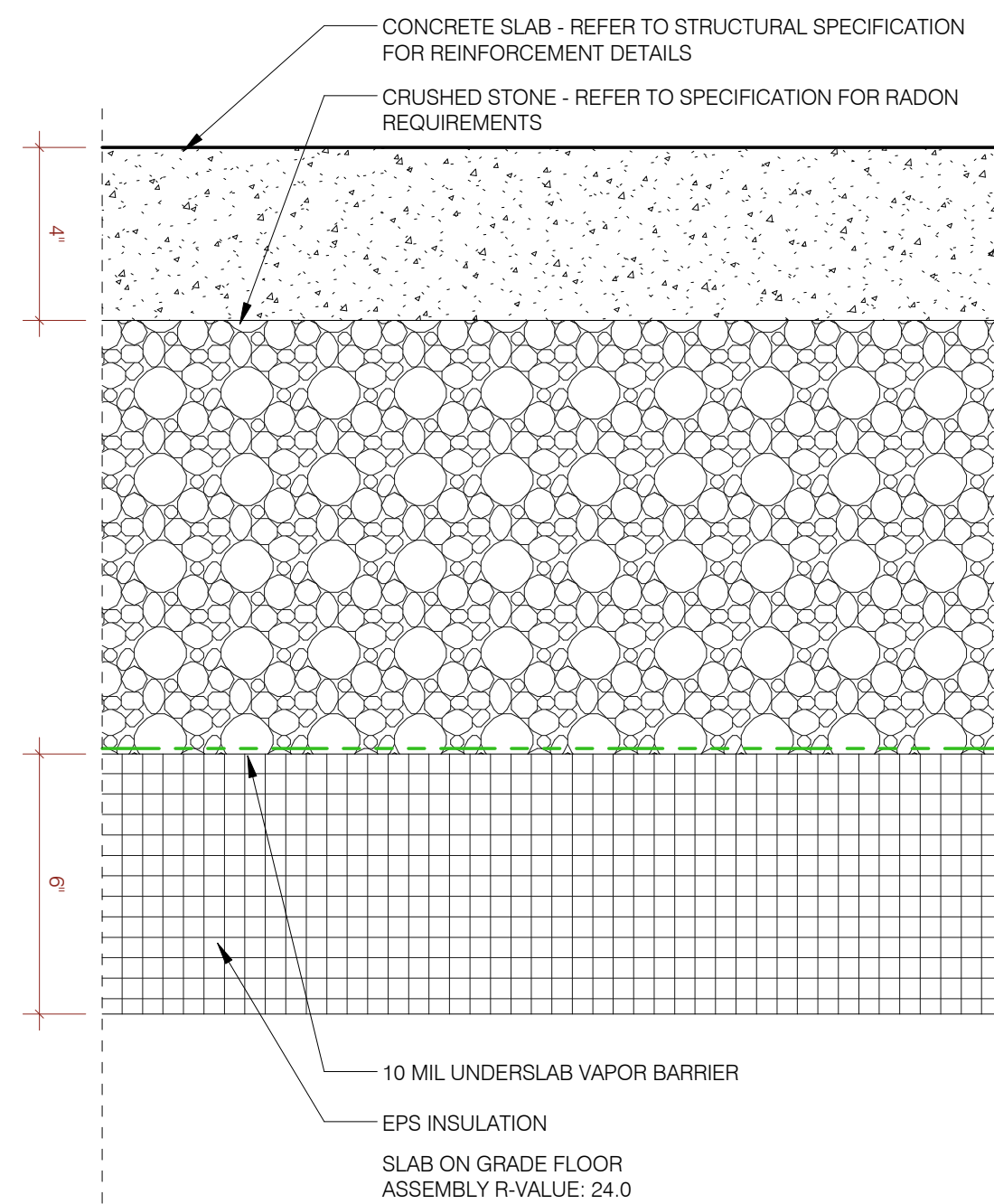

7 Assembly - First Floor Slab
3' = 1'-0"

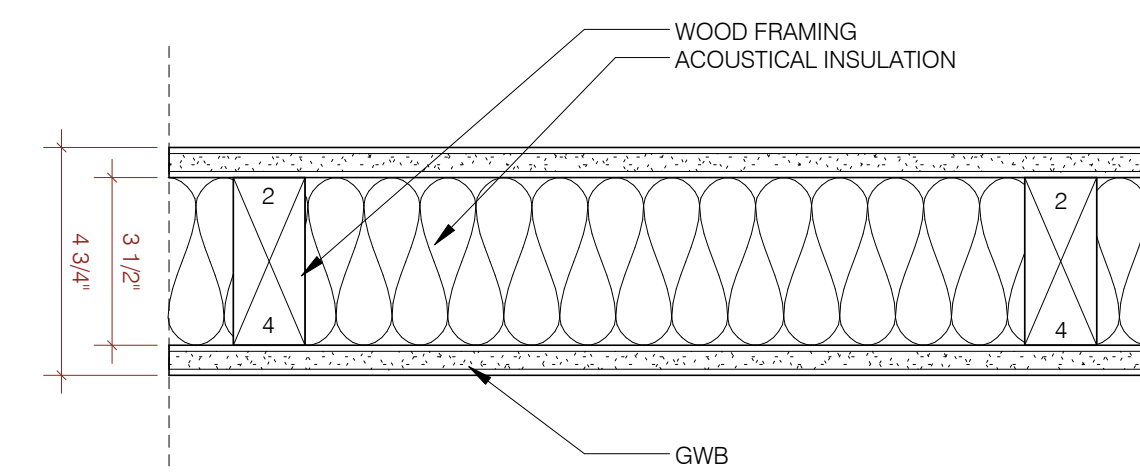

4 W4 - Assembly - Interior 2x4 Wall
3' = 1'-0"

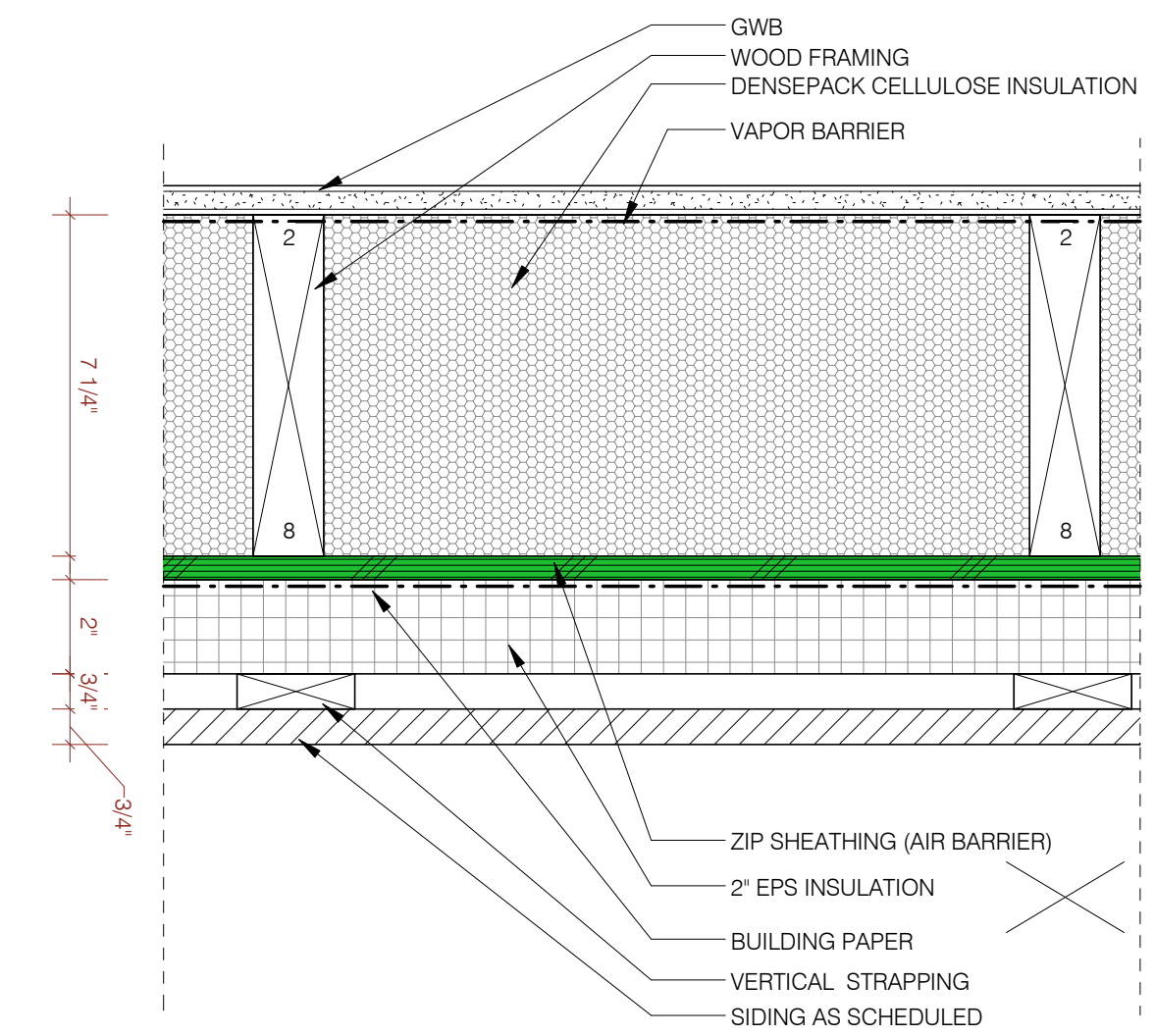

1 W1 - Assembly - Typical Exterior Wall
3' = 1'-0"

WALL ASSEMBLY R-VALUE: 34.0

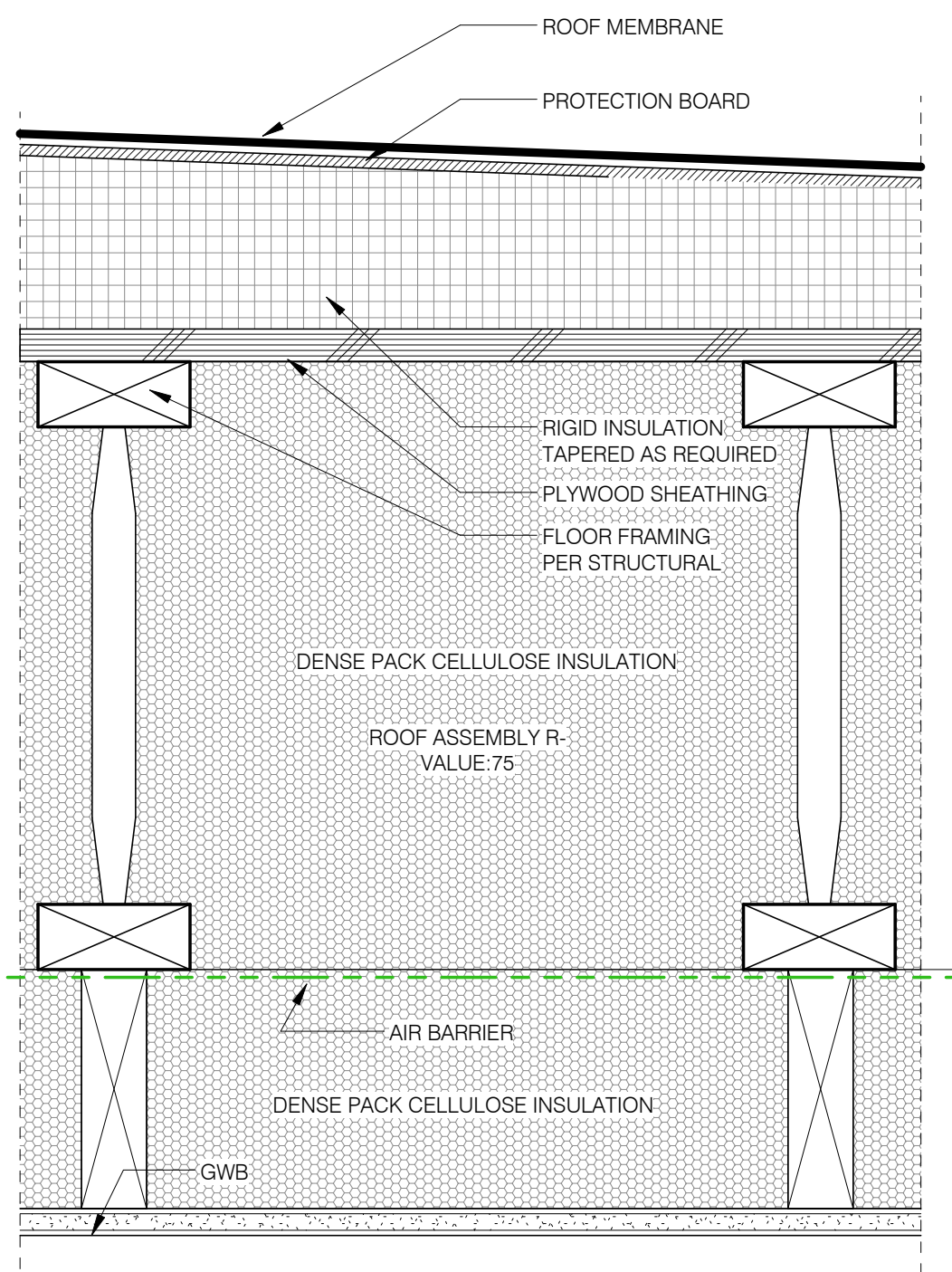

11 Assembly - Typical Roof
3' = 1'-0"

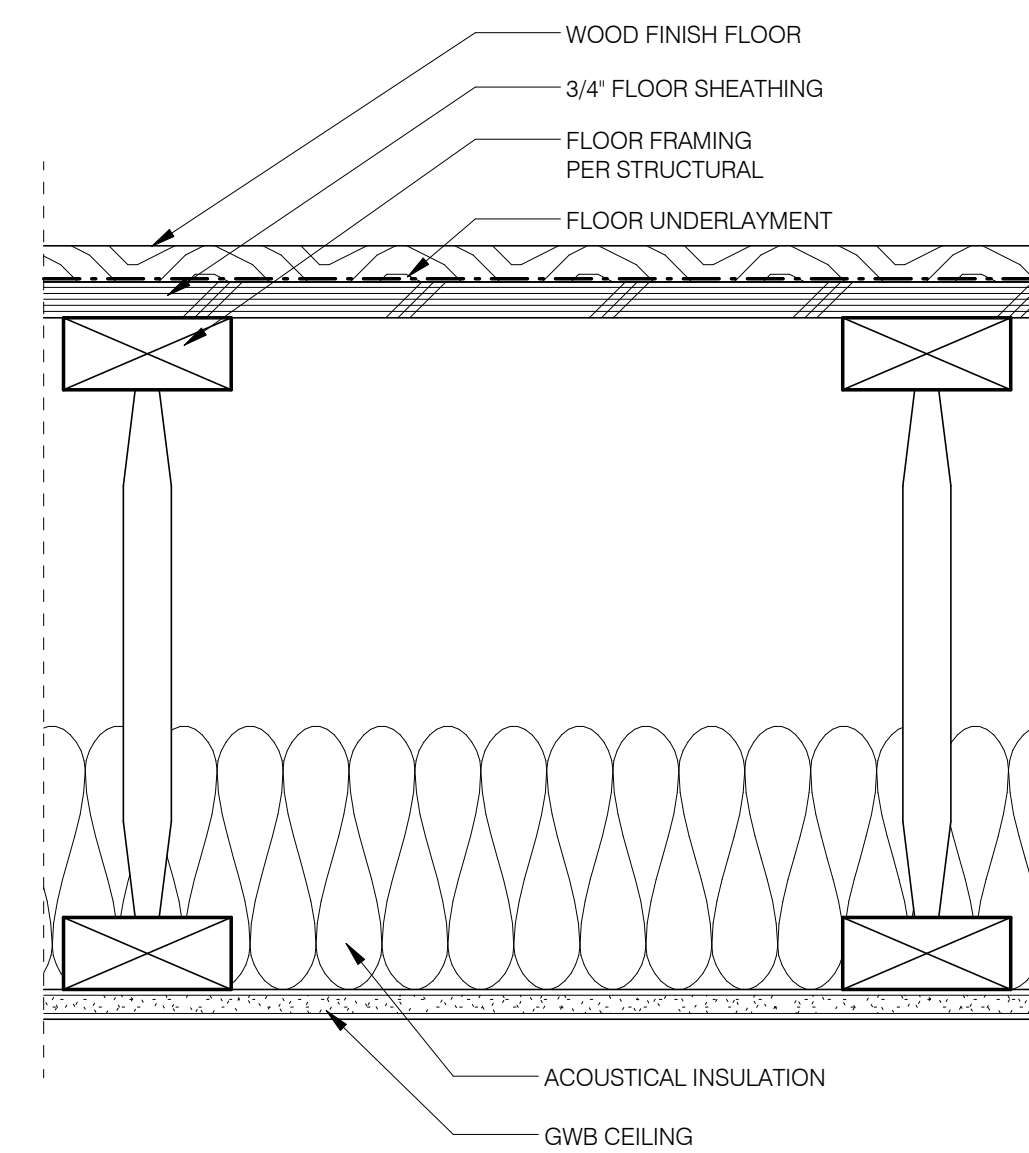

8 Assembly - Typical Second Floor
3' = 1'-0"

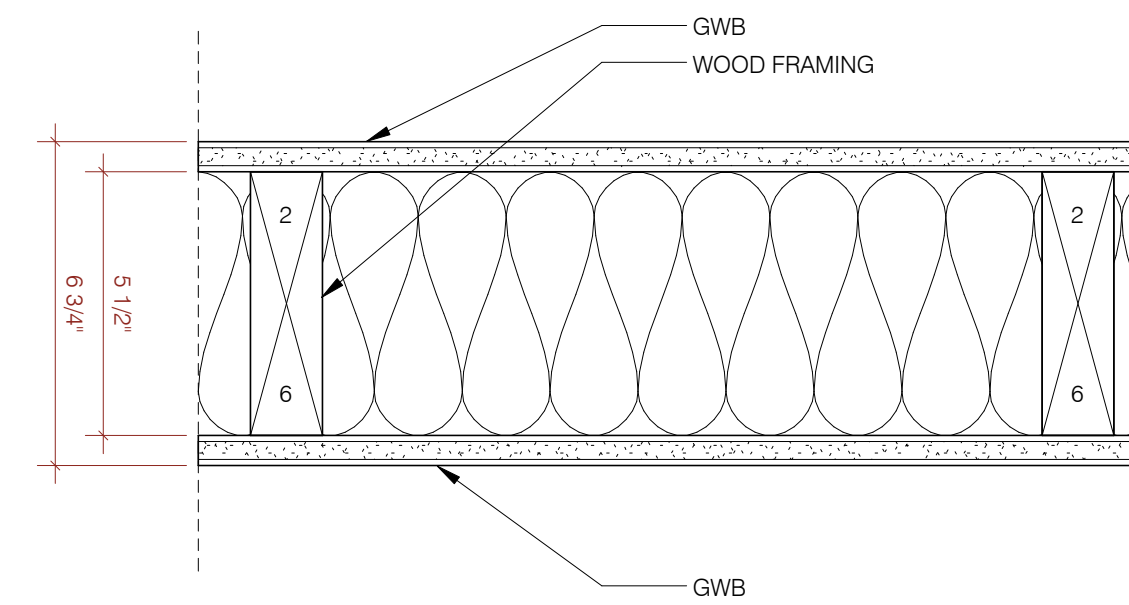

5 W5 - Assembly - Interior 2x6 Wall
3' = 1'-0"

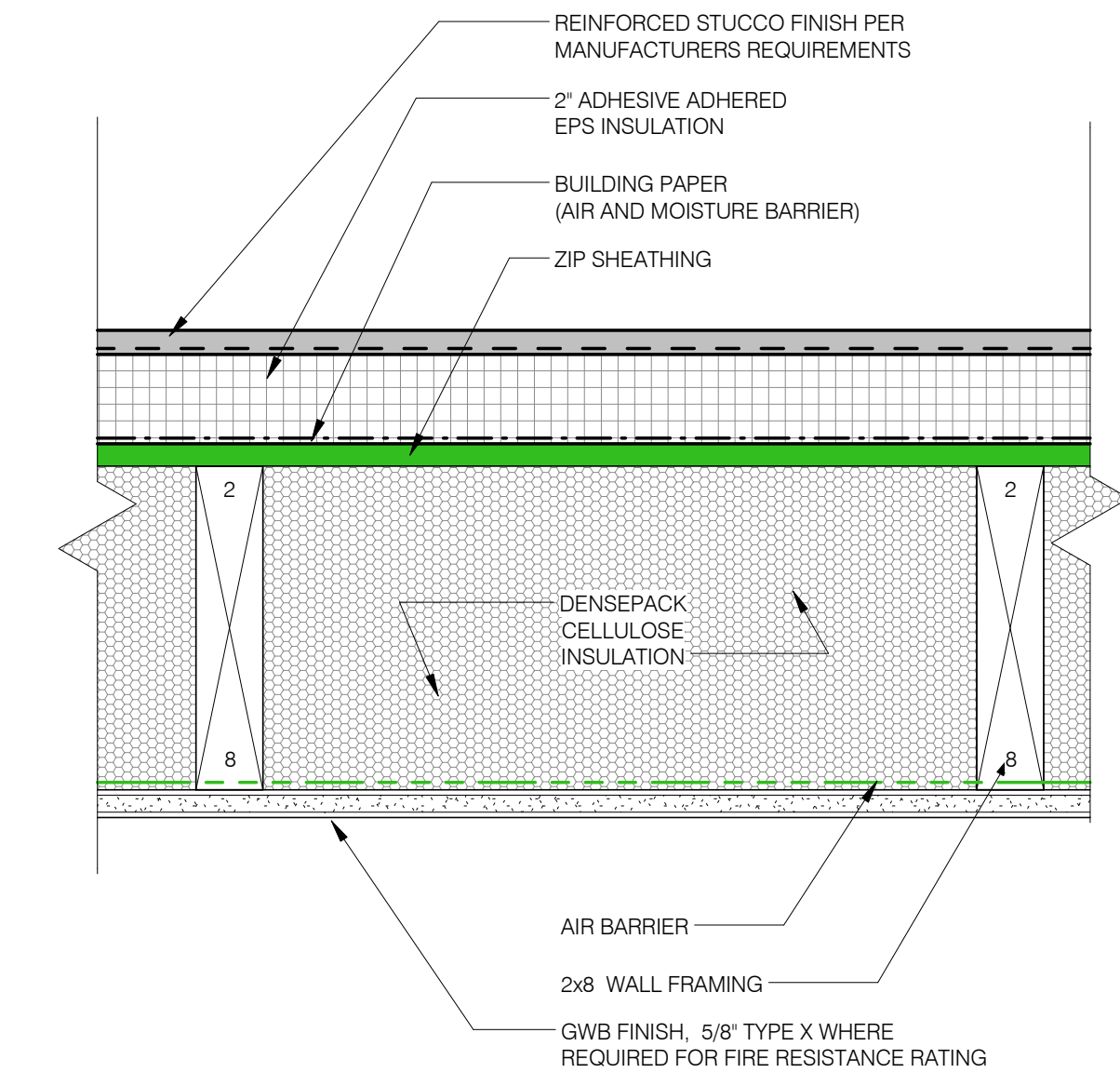

2 W3 - Exterior Wall With 2" EPS and Stucco Finish
3' = 1'-0"

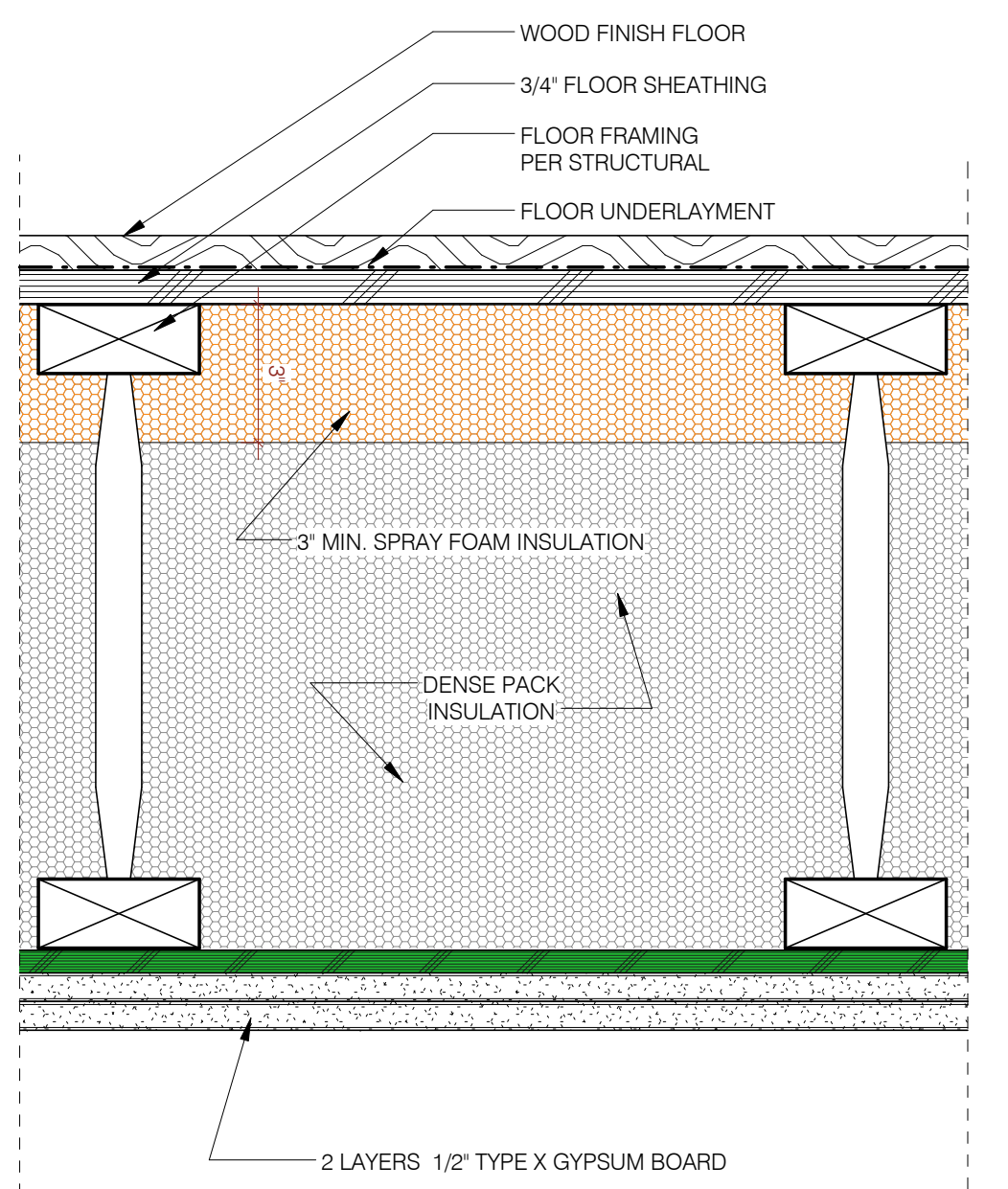

12 Garage Ceiling
3' = 1'-0"

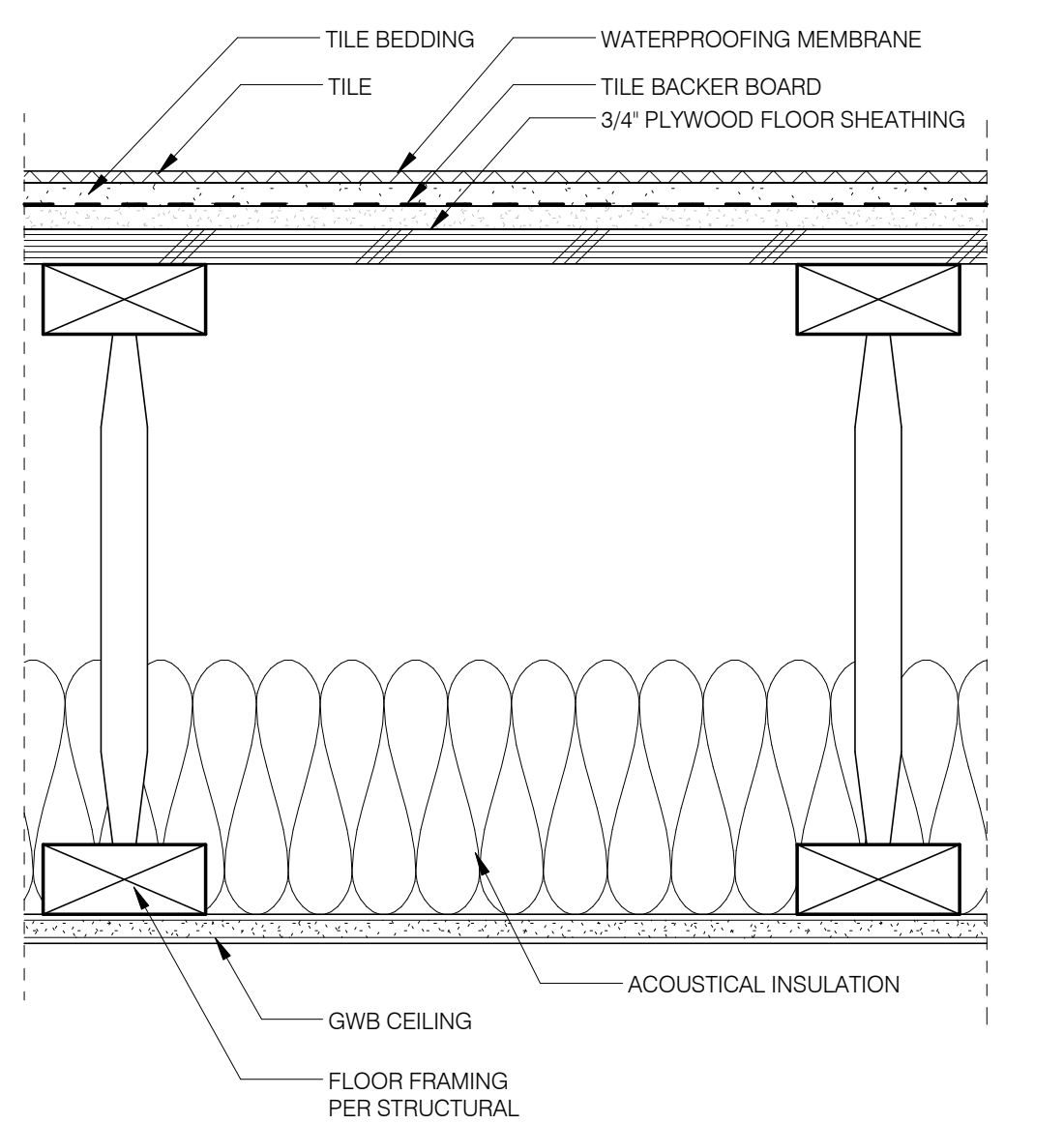

9 Assembly - Second Floor w/ Tile
3' = 1'-0"

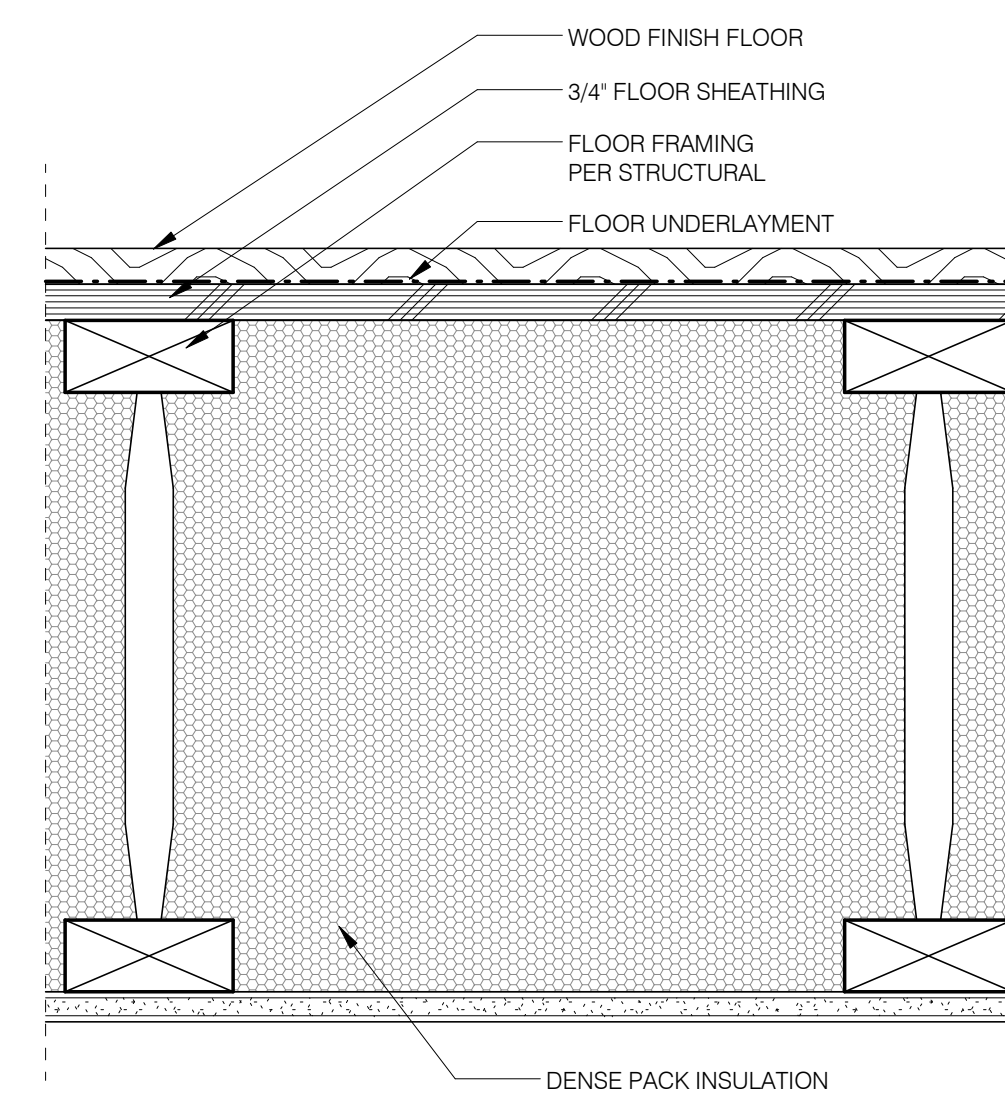

6 Assembly - First Floor Framed
3' = 1'-0"

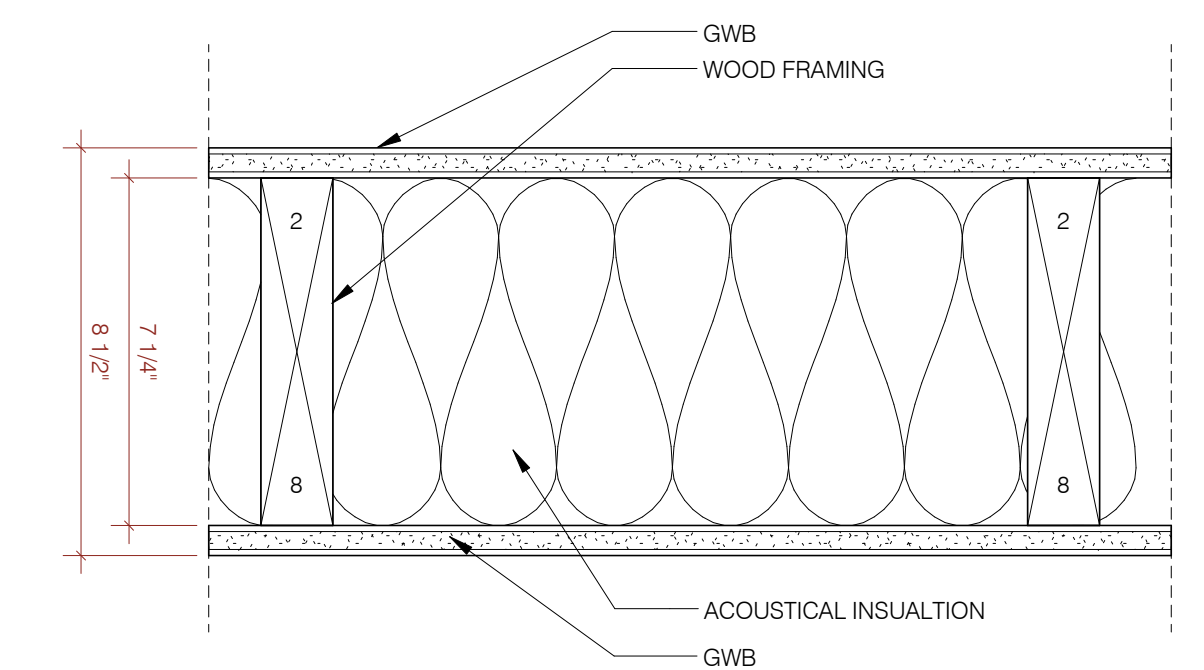

3 W6 - Assembly - Interior 2x6 Wall
3' = 1'-0"