

COPYRIGHT: Reuse or reproduction of the contents of this document is not permitted without written permission of Bild Architecture LLC

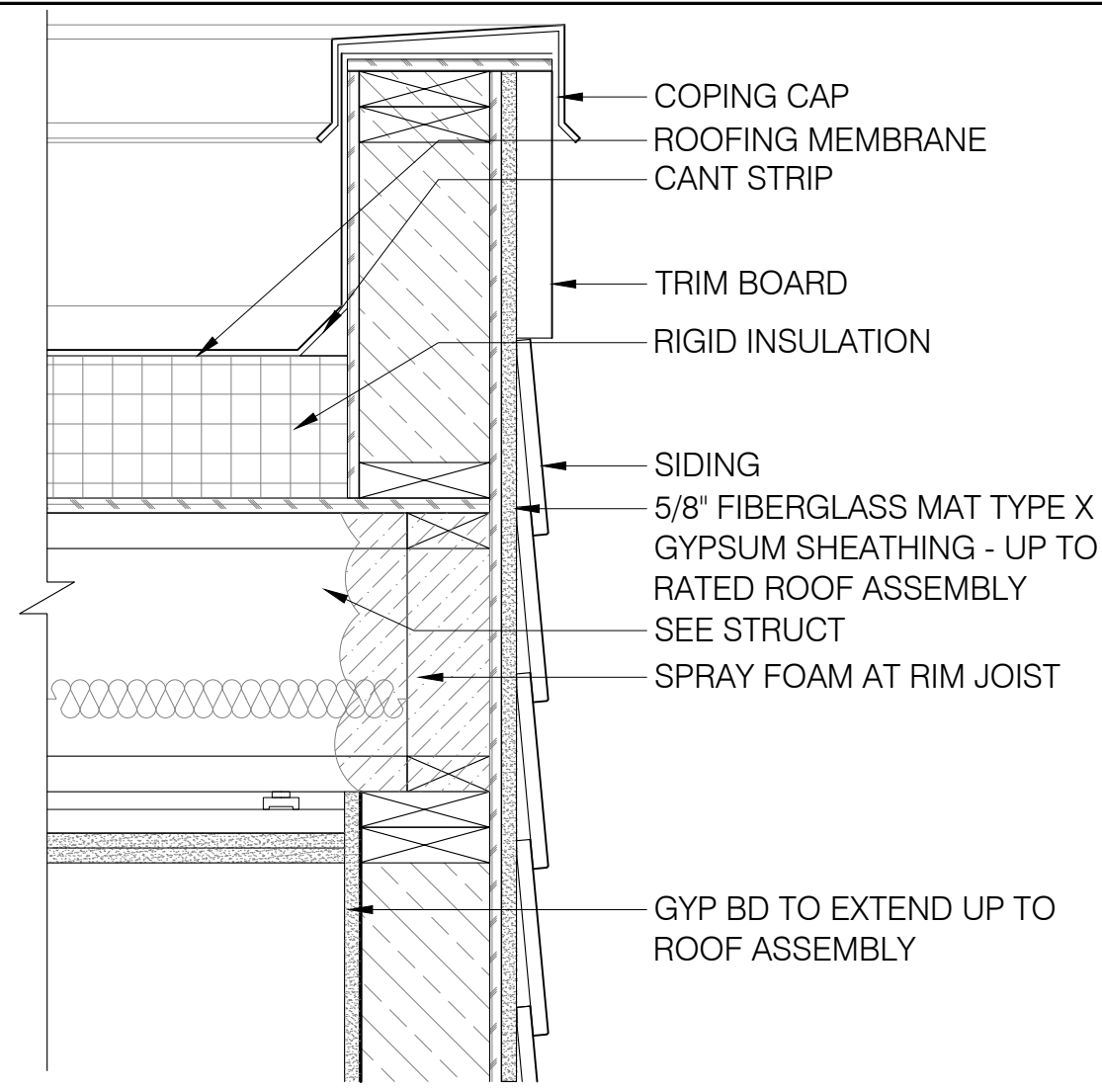

1 T.O. WALL RATED EXT. WALL
SCALE: 1-1/2" = 1'-0"

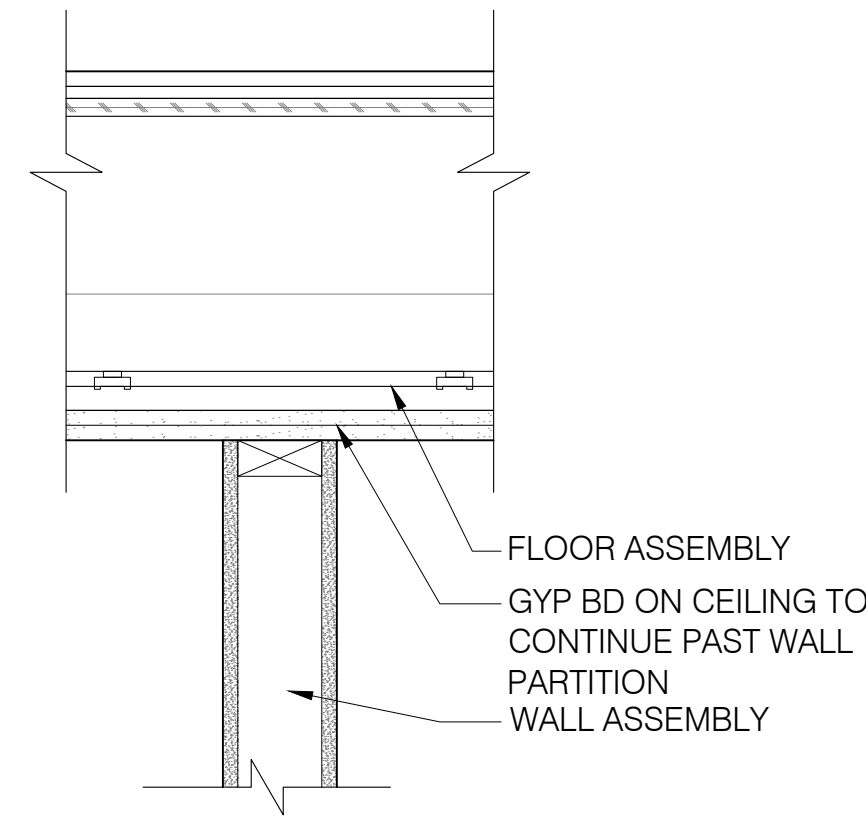

2 PARTITION UNDER RATED FLOOR
SCALE: 1-1/2" = 1'-0"

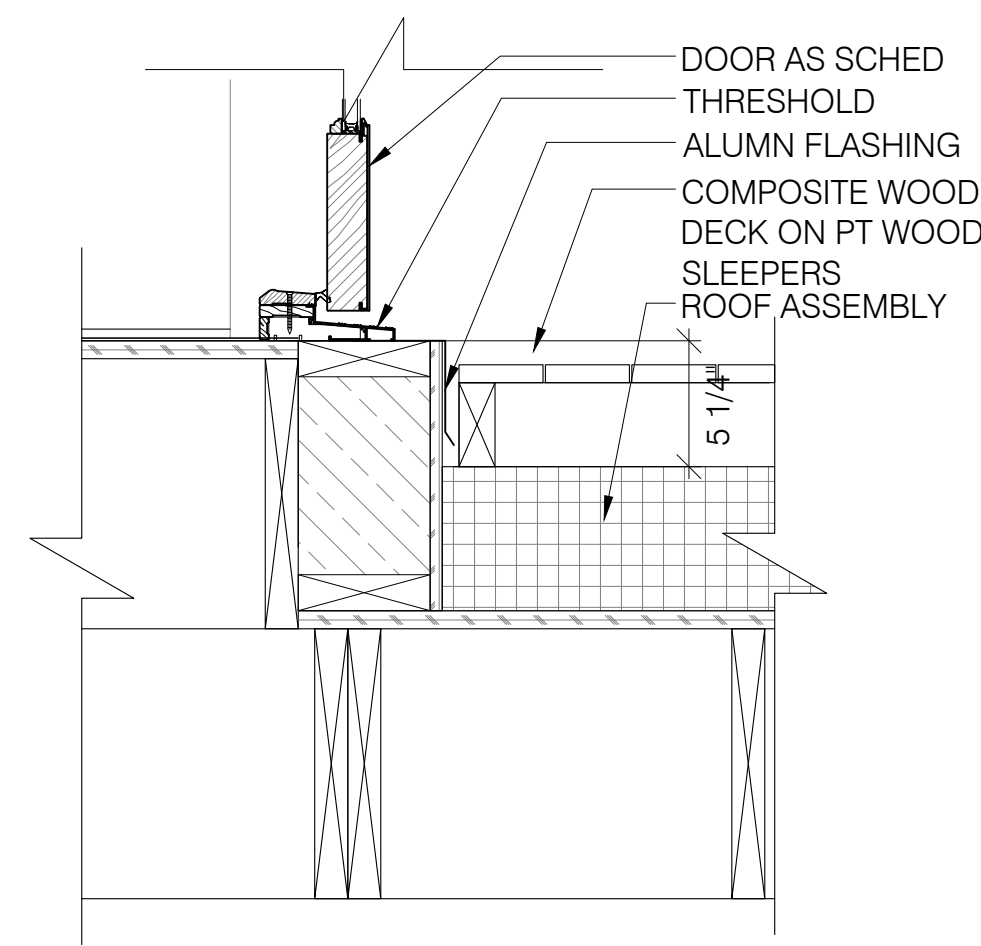

3 ROOFDECK DOOR
SCALE: 1-1/2" = 1'-0"

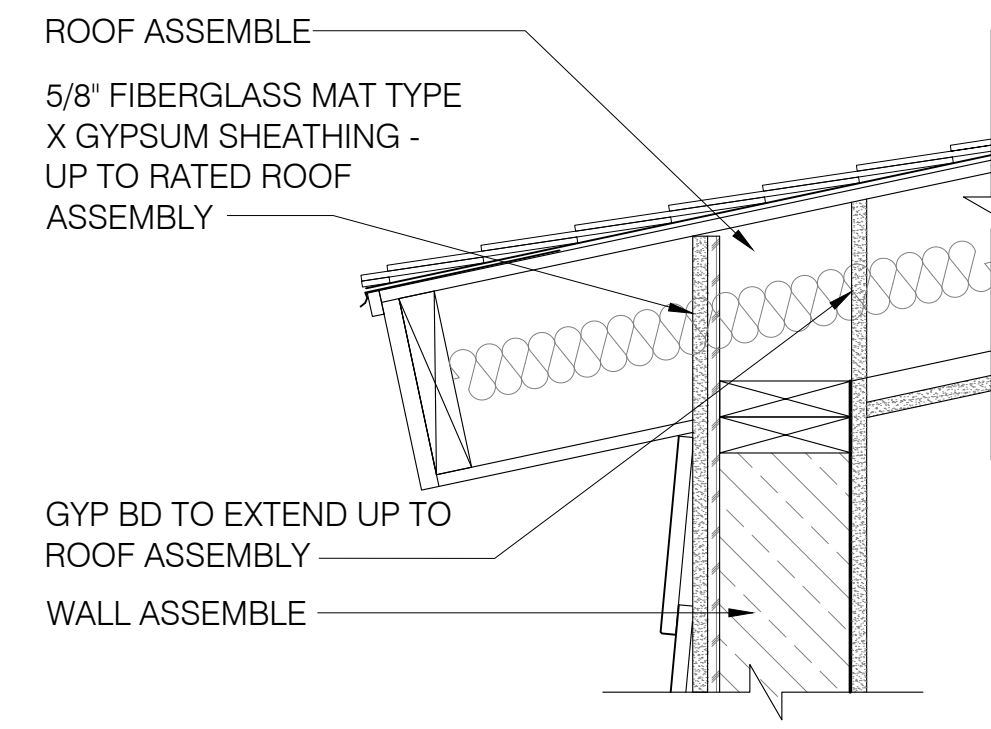

4 ROOF EAVE DETAIL
SCALE: 1-1/2" = 1'-0"

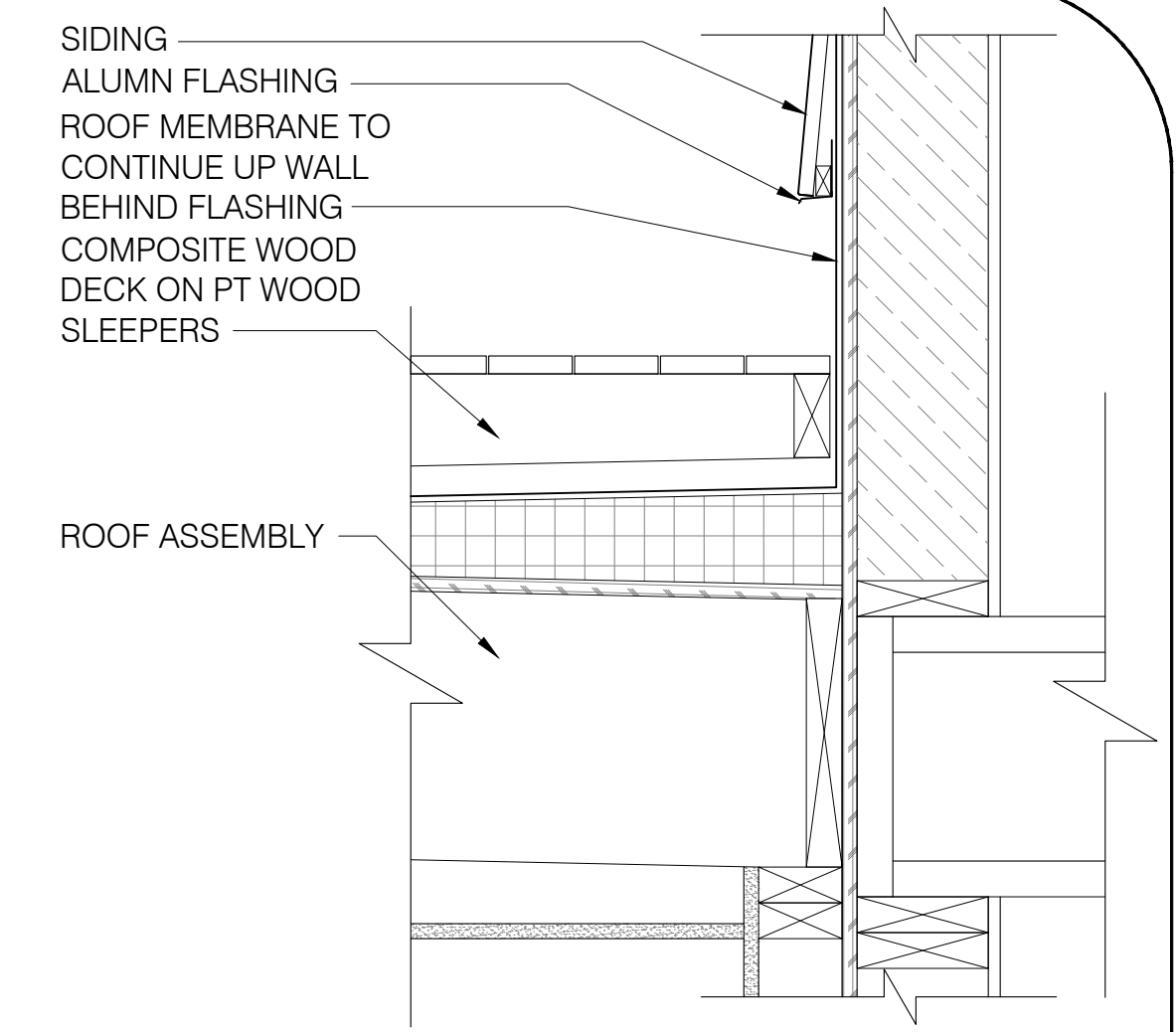

5 ROOF DECK DETAIL
SCALE: 1-1/2" = 1'-0"

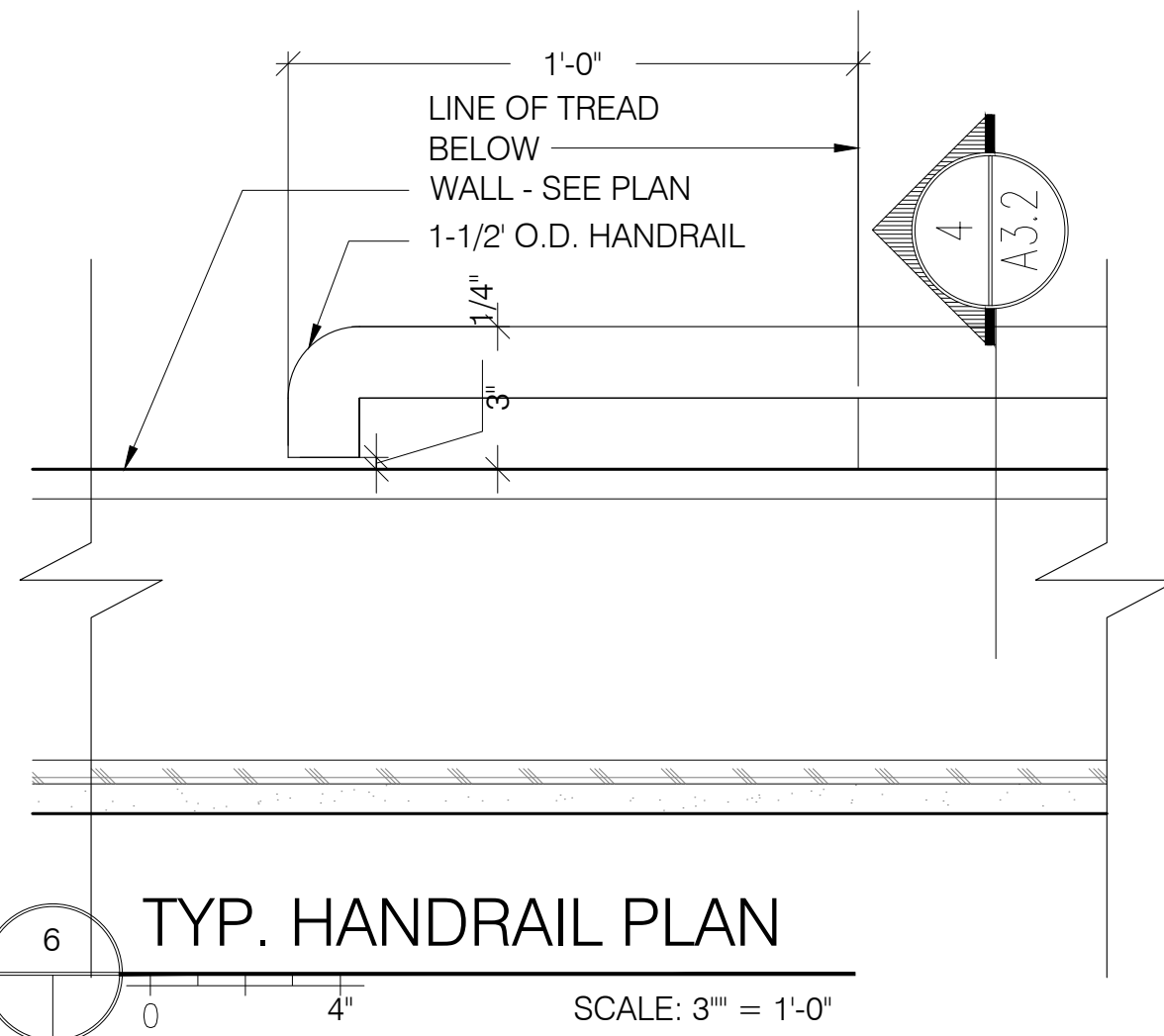

6 TYP. HANDRAIL PLAN
SCALE: 3" = 1'-0"

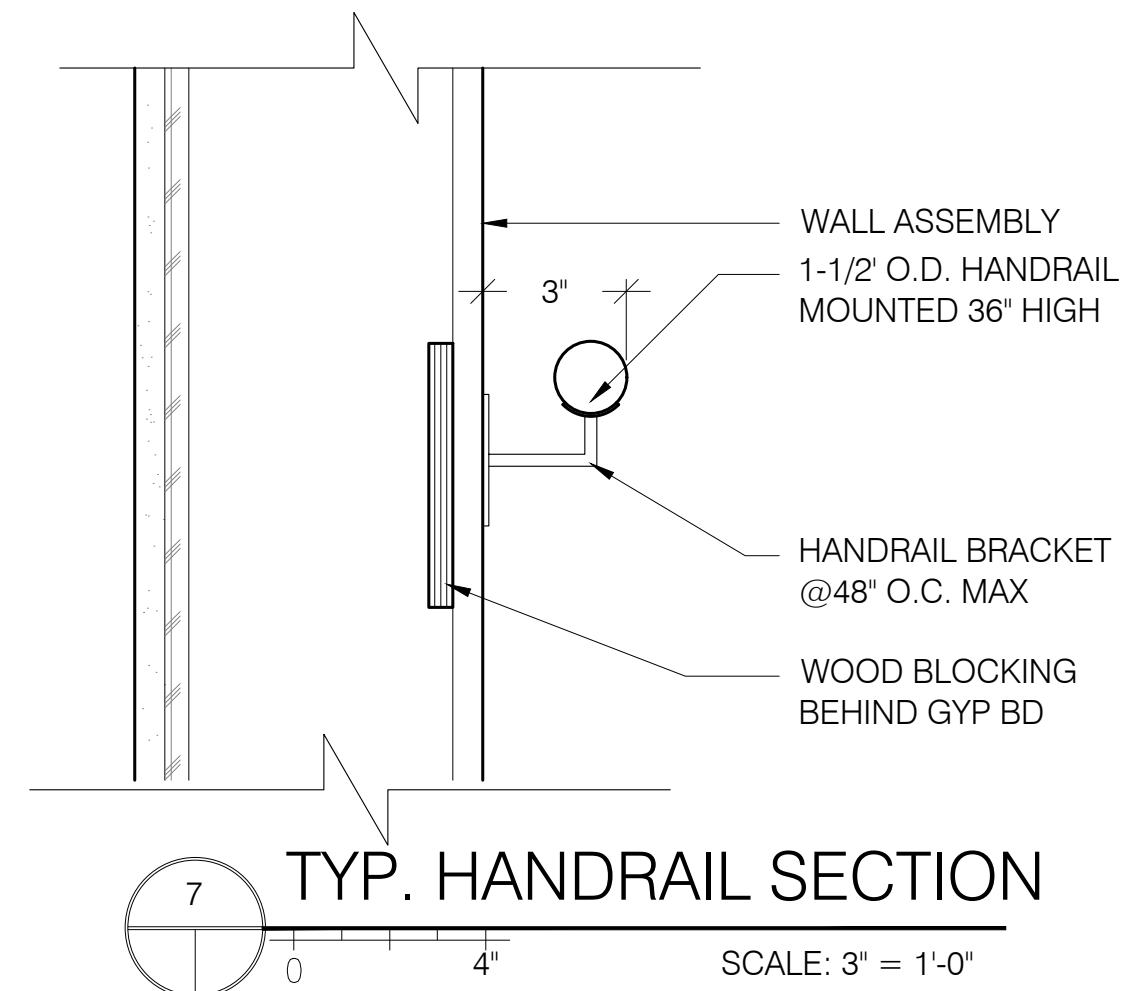

7 TYP. HANDRAIL SECTION
SCALE: 3" = 1'-0"

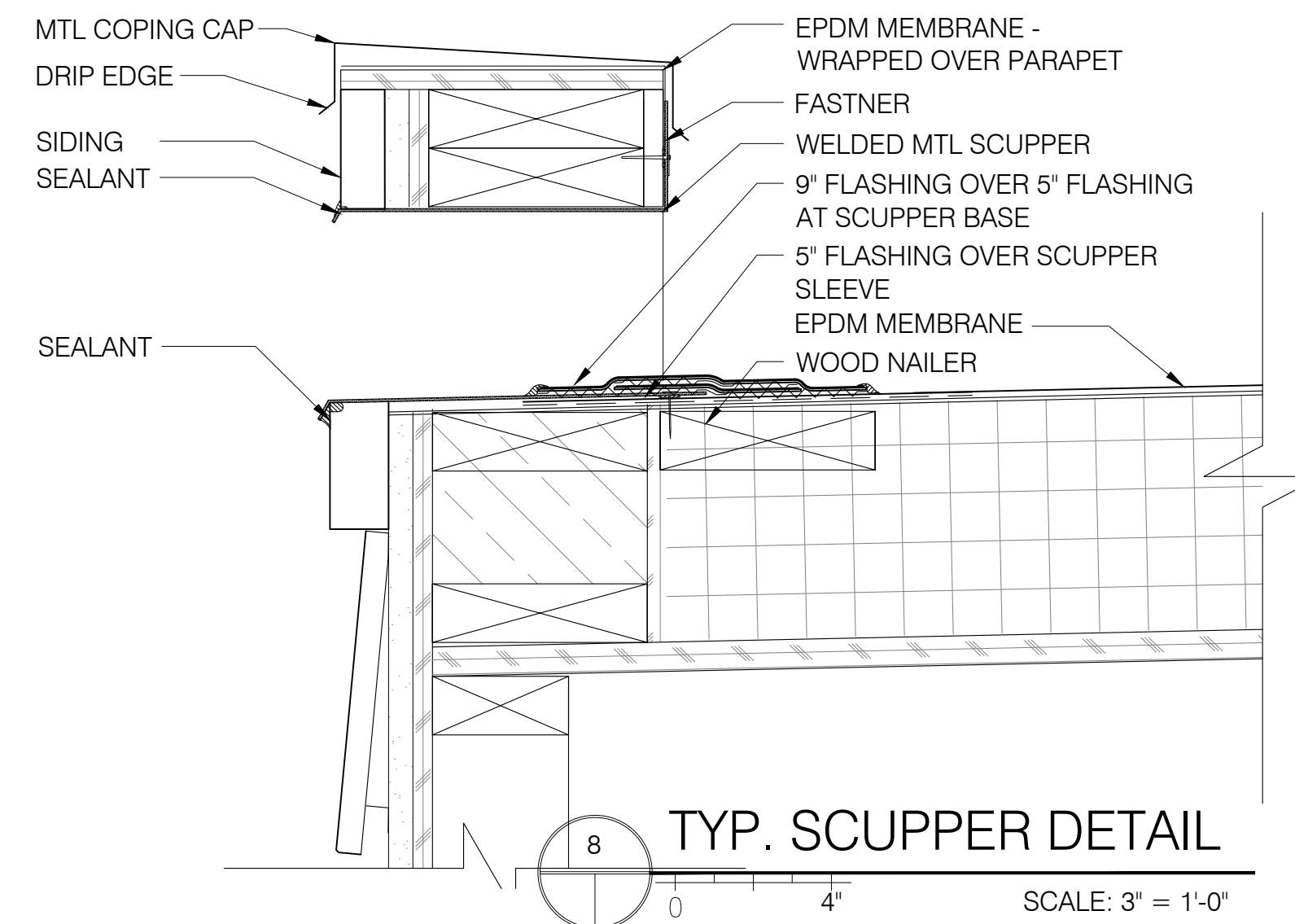

8 TYP. SCUPPER DETAIL
SCALE: 3" = 1'-0"

ISSUE DATE
2.22.17
SHEET SCALE
1/4" = 1'-0"

DRAWN BY
EMW
SHEET TITLE
DETAILS

PERMITTING DRAWINGS

REVISIONS

1	-
2	-
3	-
4	-
5	-

PROJECT NO.
16035

PROJECT NAME

44 QUEBEC
PORTLAND, ME



Bild Architecture
PO Box 8235
Portland, ME
04104
207.408.0168
evan@bildarchitecture.com

A

6