

DISPLAY THIS CARD ON PRINCIPAL FRONTAGE OF WORK

CITY OF PORTLAND

BUILDING INSPECTION

PERMIT

Please Read Application And Notes, If Any, Attached

DEPT. OF BUILDING INSPECTION CITY OF PORTLAND, ME
NOV - 8 2005

This is to certify that Bogart Salzberg/Home owner
has permission to Construction of a cement block chimney
AT 56 QUEBEC ST

provided that the person or persons who accept this permit shall comply with all of the provisions of the Statutes of Maine and of the Ordinances of the City of Portland regulating the construction, maintenance and use of buildings and structures, and of the application on file in this department.

Apply to Public Works for street line and grade if nature of work requires such information.

Notification of inspection must be given and when permission procured before this building or part thereof is altered or closed-in. 24 HOUR NOTICE IS REQUIRED.

A certificate of occupancy must be procured by owner before this building or part thereof is occupied.

OTHER REQUIRED APPROVALS

Fire Dept.
Health Dept.
Appeal Board
Other Department Name

Signature: Jamie Bouke 11/7/05
Director - Building & Inspection Services

PENALTY FOR REMOVING THIS CARD

City of Portland, Maine - Building or Use Permit Application
389 Congress Street, 04101 Tel: (207) 874-8703, Fax: (207) 874-8716

Permit No: 05-1500	Issue Date: NOV - 8 2005	CBI: 014 E002001
56 QUEBEC ST		Boeart Salzberg
56 QUEBEC ST		Phone:

RECEIVED

Home owner Portland	Permit Type: Amendment to Single Family	Zone: R6
Lessee/Buyer's Name	Permit Fee: \$39.00	Cost of Work: \$1,200.00
Past Use: Single Family	Proposed Use: Single Family ammend permit # 05-1362 construction of a cement block chimney	CEO District: 1
<input type="checkbox"/> Approved <input type="checkbox"/> Denied		INSPECTION: Use Group R3 Type: Chimney IRC-2003/6 FPA 211 Signature: AMB 11/7/05
Action: <input type="checkbox"/> Approved <input type="checkbox"/> Approved w/Conditions <input type="checkbox"/> Denied		Signature: _____ Date: _____

Permit Taken By: dmartin	Date Applied For: 10/31/2005	Zoning Approval
-----------------------------	---------------------------------	------------------------

Special Zone or Reviews <input type="checkbox"/> Shoreland <input type="checkbox"/> Wetland <input type="checkbox"/> Flood Zone <input type="checkbox"/> Subdivision <input type="checkbox"/> Site Plan Maj <input type="checkbox"/> Minor <input type="checkbox"/> MM <input type="checkbox"/> Date: AMB 11/7/05	Zoning Appeal <input type="checkbox"/> Variance <input type="checkbox"/> Miscellaneous <input type="checkbox"/> Conditional Use <input type="checkbox"/> Interpretation <input type="checkbox"/> Approved <input type="checkbox"/> Denied Date:	Historic Preservation <input checked="" type="checkbox"/> Not in District or Landmark <input type="checkbox"/> Does Not Require Review <input type="checkbox"/> Requires Review <input type="checkbox"/> Approved <input type="checkbox"/> Approved w/Conditions <input type="checkbox"/> Denied Date:
--	--	---

CERTIFICATION

I hereby certify that I am the owner of record of the named property, or that the proposed work is authorized by the owner of record and that I have been authorized by the owner to make this application as his authorized agent and I agree to conform to all applicable laws of this jurisdiction. In addition, if a permit for work described in the application is issued, I certify that the code official's authorized representative shall have the authority to enter all areas covered by such permit at any reasonable hour to enforce the provision of the code(s) applicable to such permit.

SIGNATURE OF APPLICANT	ADDRESS	DATE	PHONE
RESPONSIBLE PERSON IN CHARGE OF WORK, TITLE		DATE	PHONE

City of Portland, Maine - Building or Use Permit

389 Congress Street, 04101 Tel: (207) 874-8703, Fax: (207) 874-8716

Permit No: 05-1600	Date Applied For: 1013112005	CBL: 014 E002001
Location of Construction: 56 QUEBEC ST	Owner Name: Bogart Salzberg	Owner Address: 56 QUEBEC ST
Business Name:	Contractor Name: Home owner	Contractor Address: Portland
Tenant/Buyer's Name	Phone:	Permit Type: Amendment to Single Family
Proposed Use: Single Family ammend permit # 05-1362 construction of a cement block chimney		Proposed Project Description: Construction of a cement block chimney



Comments:

11/07/2005-jmb: received pdf of more detail, ok to issue
 11/07/2005-jmb: Bogart S. Called 1111 to schedule a same day review

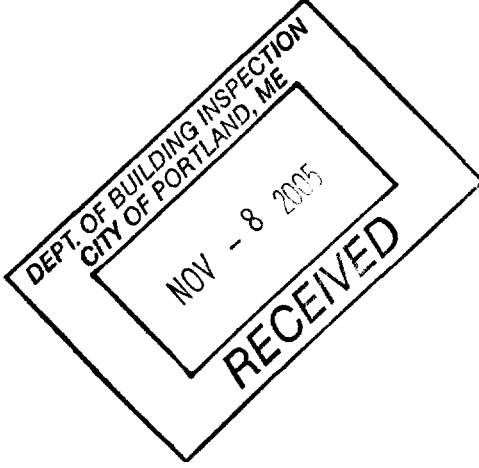



If you or the property within the

Total Square Footage of Proposed Structure <u>56</u> <u>~ 4</u>		Square Footage of Lot <u>1720</u>
Chart# <u>014</u>	Block# <u>E 002</u>	Lot# <u>Bogart + Salzburg</u>
Lessee/Buyer's Name (If Applicable)	Applicant name, address & telephone: <u>owner</u> <u>25 Melbourne St. 828-4401</u>	Cost Of Work: \$ <u>~1200</u> Fee: \$ <u>39.00</u> C of O Fee: \$
Current Specific use:	<u>SIP</u>	
Proposed Specific use:	<u>amendment to permit</u>	
Project description:	<u>construction of cement block chimney</u>	
Contractor's name, address & telephone:		
Who should we contact when the permit is ready:	<u>owner</u>	
Mailing address:	Phone: <u>828-4401</u> ✓ +	
<u>25 Melbourne St. Portland ME 04101</u>		

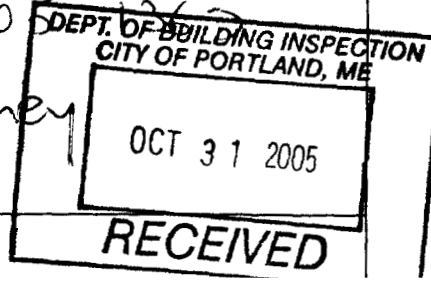

Please submit all of the information outlined in the Commercial Application Checklist. Failure to do so will result in the automatic denial of your permit.

In order to be sure the City fully understands the full scope of the project, the Planning and Development Department may request additional information prior to the issuance of a permit. For further information Visit us on-line at www.portlandmaine.gov, stop by the Building Inspections office, room 315 City Hall or call 874-8703.

I hereby certify that I am the Owner of record of the named property, or that the owner of record authorizes the proposed work and that I have been authorized by the owner to make this application as his/her authorized agent. I agree to conform to all applicable laws of this jurisdiction. In addition, if a permit for work described in this application is issued, I certify that the Code Official's authorized representative shall have the authority to enter all areas covered by this permit at any reasonable hour to enforce the provisions of the codes applicable to this permit.

Signature of applicant: <u>Bogart Salzburg</u>	Date: <u>Oct 28, 2005</u>
--	---------------------------

This is not a permit; you may not commence ANY work until the permit is issued.

flue slightly larger than 8" x 8" to fit 8" liner with space

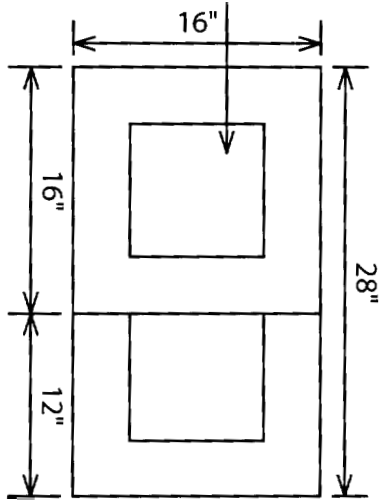

a typical course of cement block. (courses staggered to prevent continuous vertical seam).

flue liners extend to 8" or more below lowest inlet

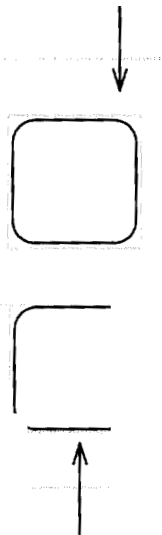

8" fireclay tile liner (2), freestanding with air space on all sides not exceeding tile width.

Nov. 5, 2005
(file with plan dated Oct. 27, 2005)
scale: 1" = 1'

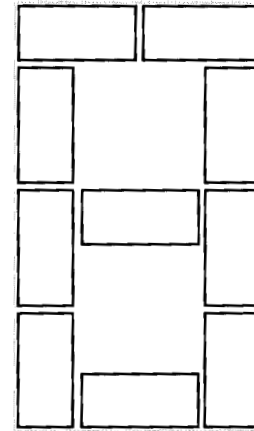

a typical course of brick. (courses staggered).

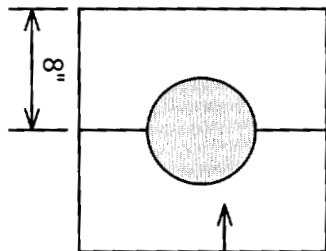

7" metal thimble

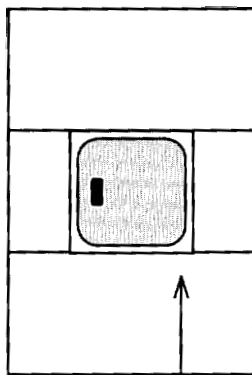
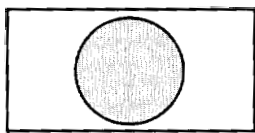

cleanout door on each flue, within

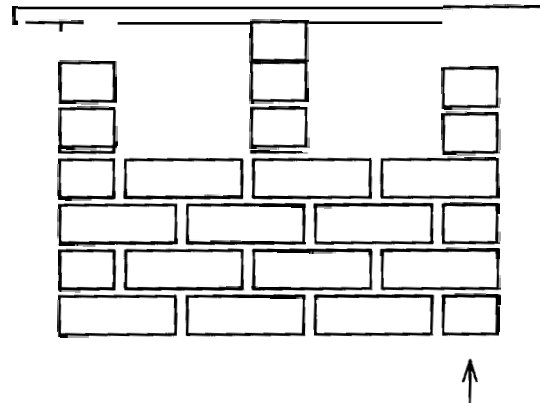

56 Quebec Street
Proposed **Amendment** to Permit on File:
Constru^{ct}ion of tile-lined double-flue
cement block chimney

Chimney Construction Details



BUILDING PERMIT INSPECTION PROCEDURES

Please call 874-8703 or 874-8693 to schedule your inspections as agreed upon

Permits expire in 6 months, if the project is not started or ceases for 6 months.

The Owner or their designee is required to notify the inspections office for the following inspections and provide adequate notice. Notice must be called in 48-72 hours in advance in order to schedule an inspection:

By initializing at each inspection time, you are agreeing that you understand the inspection procedure and additional fees from a "Stop Work Order" and "Stop Work Order Release" will be incurred if the procedure is not followed as stated below.

A Pre-construction Meeting will take place upon receipt of your building permit.

- Footing/~~Building~~ Location Inspection: Prior to pouring concrete
- ~~N/A~~ Re-Bar Schedule Inspection: Prior to pouring concrete
- ~~N/A~~ Foundation Inspection: Prior to placing ANY backfill
- ~~N/A~~ Framing/Rough Plumbing/Electrical: Prior to any insulating or drywalling
- Final/~~Certificate of Occupancy~~: Prior to any occupancy of the structure or use. NOTE: There is a ~~\$75.00 fee per~~ inspection at this point.

Certificate of Occupancy is not required for certain projects. Your inspector can advise you if your project requires a Certificate of Occupancy. All projects DO require a final inspection

If any of the inspections do not occur, the project cannot go on to the next phase, REGARDLESS OF THE NOTICE OR CIRCUMSTANCES.

~~N/A~~ **CERTIFICATE OF OCCUPANCIES MUST BE ISSUED AND PAID FOR, BEFORE THE SPACE MAY BE OCCUPIED**

X Bogant Jahng
Signature of Applicant/Designee

11/8/05
Date

Alowe
Signature of Inspections Official

11/8/05
Date

CBL: 14-2 Building Permit # 05/1400

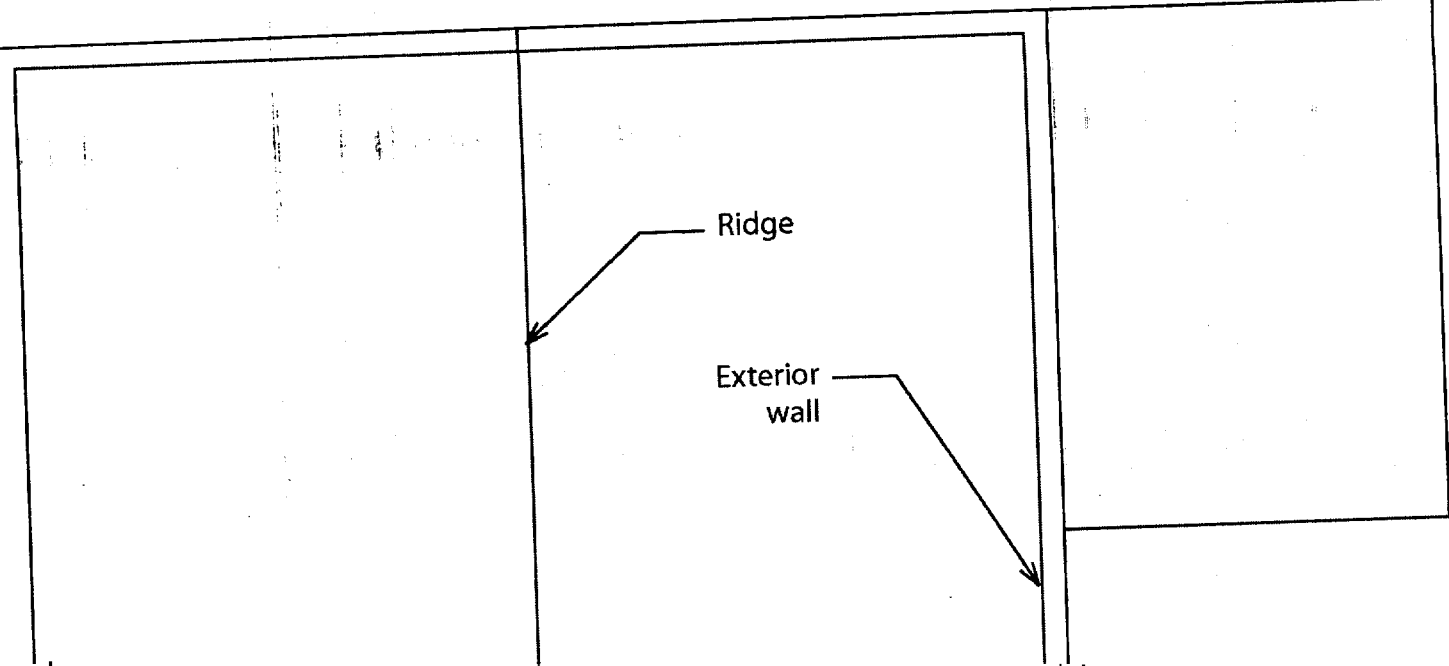

56 Quebec Street
Proposed Amendment to Permit on File:
Construction of tile-lined double-flue
cement block chimney

Plot Plan

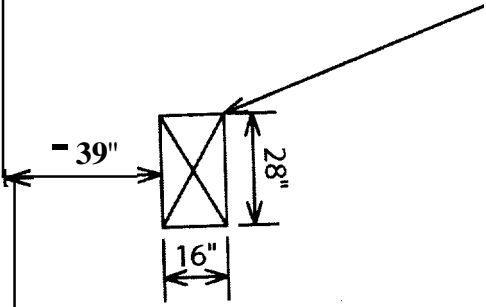

New 32'
double-flue
block
chimney,
typical
construction
with tile liners

to comply with
NFPA-211

Oct. 27, 2005
scale: 1/4" : 1'

Oct. 27, 2005
scale: 1" = 1'

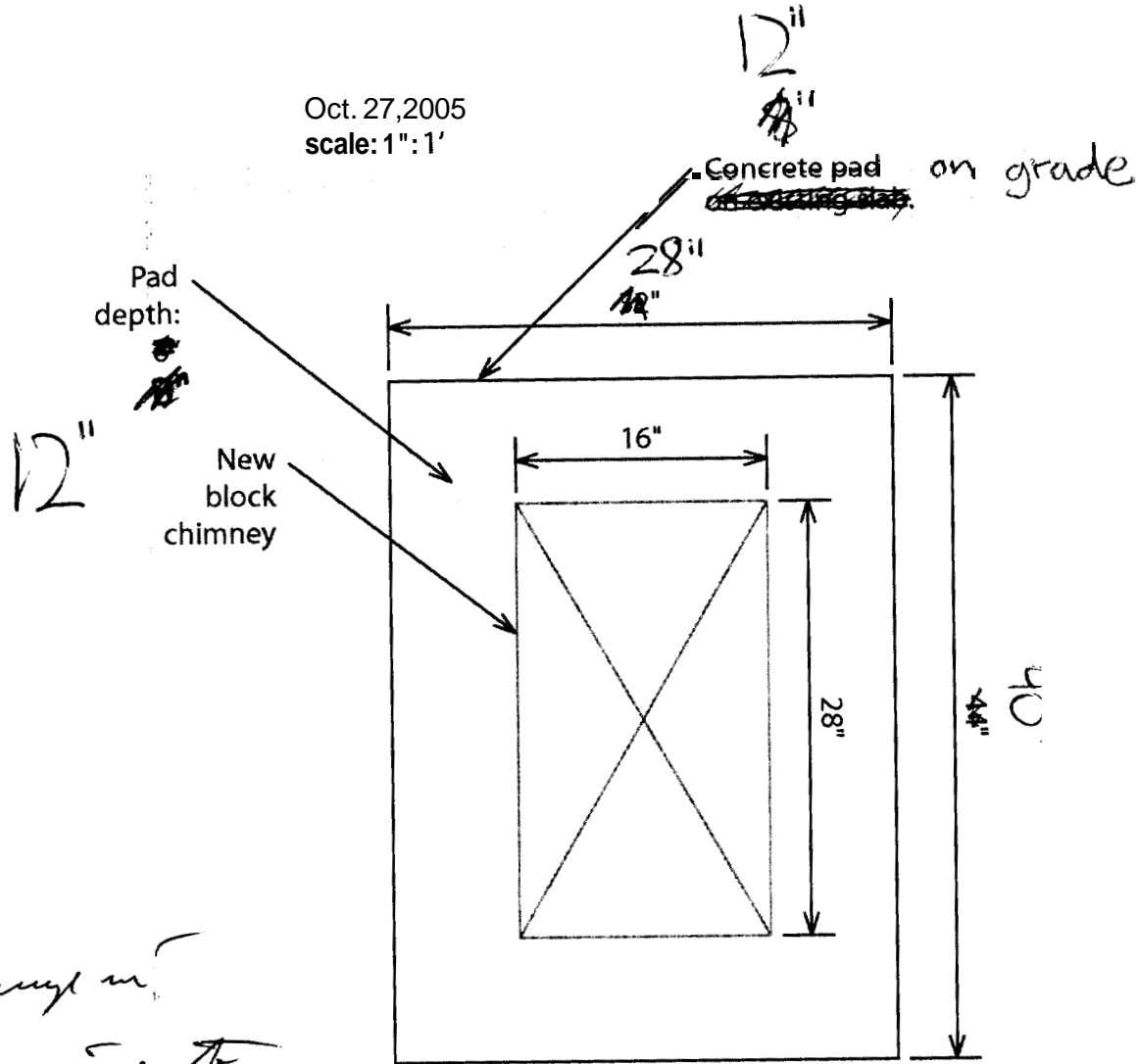

*change in
dimensions to*

conform to Chap 10: R1001.1.1

56 Quaker Street

[Signature]
11/8/05

Proposed **Amendment** to Permit on File:
Construction of tile-lined double-flue
cement block chimney

Basement Floor

Oct. 27, 2005
scale: 1" : 1'

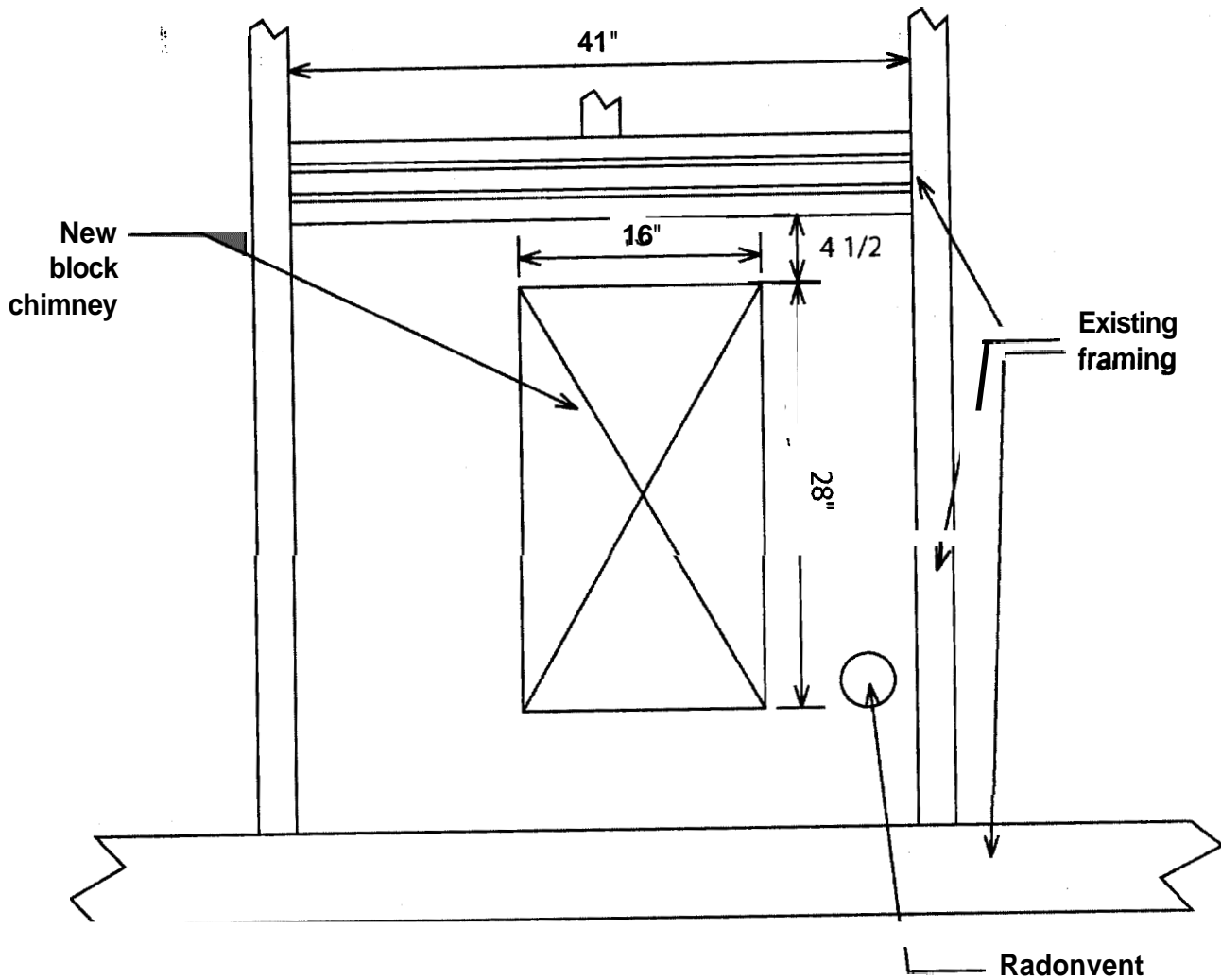

56 Quebec Street
Proposed Amendment to Permit on File:
Construction of tile-lined double-flue
cement block chimney

First Floor Framing

10-27-05

Oct. 27, 2005
scale: 1" : 1'

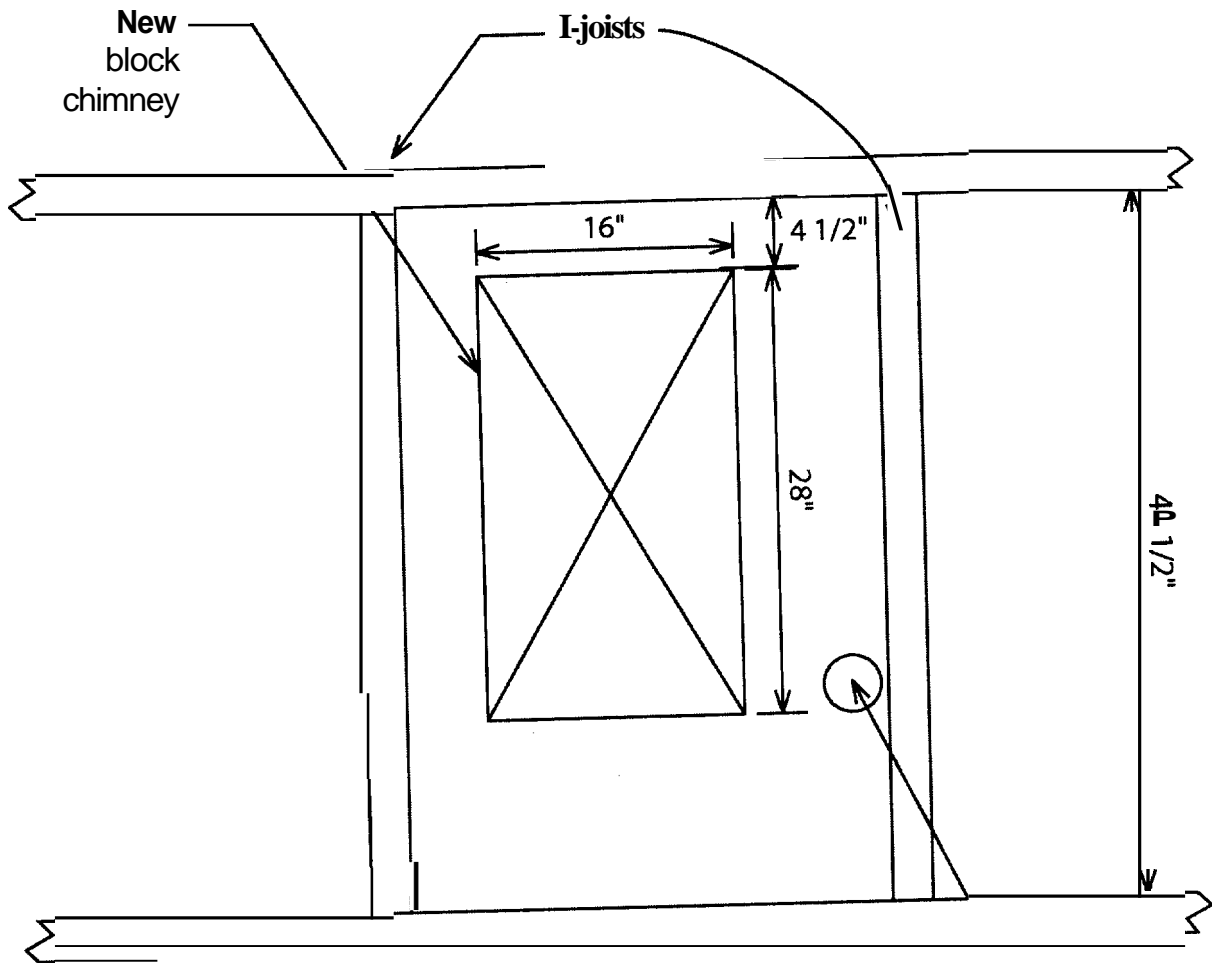

Second Floor Framing

Oct. 27, 2005
scale: 1" = 1'

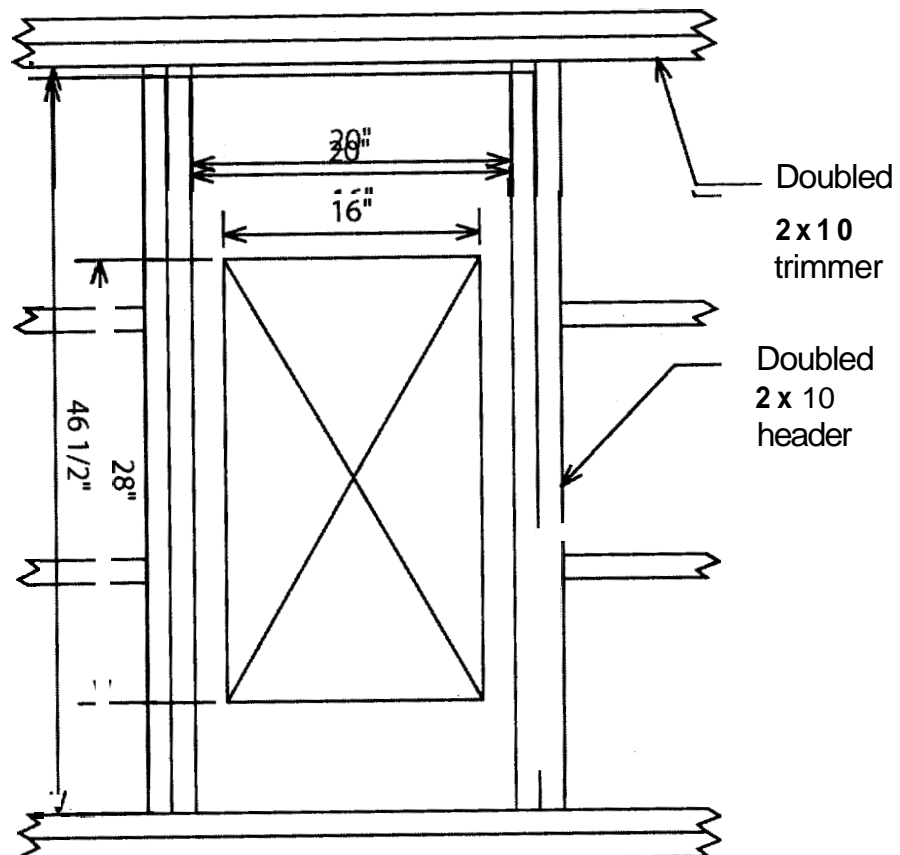

Note: Location of chimney within opening is approximate.
A minimum 2" clearance will be maintained.

56 Quebec Street
Proposed Amendment to Permit on File:
Construction of tile-lined double-flue
cement block chimney

Roof Framing

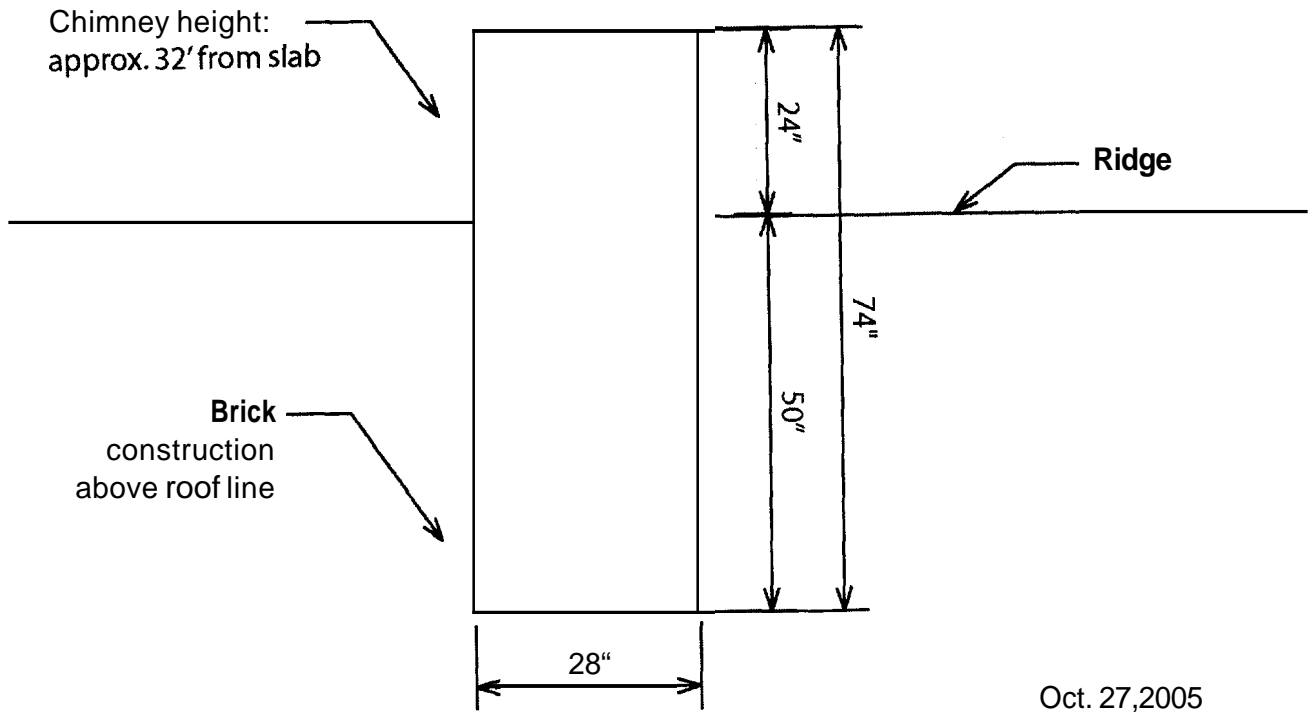

Oct. 27, 2005
scale: 1/2" : 1'

Note: Cap, corbel and liner details are not shown

56 Quebec Street
Proposed **Amendment** to Permit **on File**:
Construction of tile-lined double-flue
cement block chimney

New Chimney, Side View, Above *Roof* Surface



From: Bogart Salzberg <webmaster@inkfist.com>
To: Jeanie Bourke <JMB@portlandmaine.gov>
Date: 11/08/2005 1:56:54 **PM**
Subject: Re: 56 Quebec Street chimney

Jeanie,

Thanks for your help with this.

Best Regards,

Bogart Salzberg

On Nov 8, 2005, at 8:15 **AM**, Jeanie Bourke wrote:

- > No problem...I did issue the permit. The info about the height of
- > the cleanout is in the NFPA 211 code from 2000, I'm not sure if we
- > have adopted a more recent edition. I strongly suggest that you
- > take a look at this code and make copies of relevant sections.
- > Feel free to use my copy for reference here in our office.