

Features

- Isolates short circuits within the SLC loop.
- SLC Class A, Class X & Class B
- Mounts in a standard 4" or double gang box
- Wire terminals accessible when mounted in box
- All wiring terminals accept 22 to 12 AWG
- Product includes a 5 year warranty



Description

The PAD100-IM module does not require an SLC loop address but does consume power from the SLC loop. The module provides protection against short circuits by limiting the number of affected devices. When the PAD100-IM detects a short circuit on the SLC loop, it disconnects the outgoing side of the module to prevent the short from affecting the rest of the SLC loop. The PAD100-IM includes one red LED to indicate the modules status. When the module is shorted, the LED will light continuously. Once the short is removed, the PAD100-IM will automatically restore to a cleared condition.

Application

The PAD100-IM is compatible with Potter's IPA series addressable fire alarm control panels. The PAD100-IM is used to provide additional reliability by isolating a segment of the SLC loop where a short circuit has occurred.

Technical Specifications

Operating Voltage	24.0V
Max SLC Standby Current	100µA
Max SLC Short Circuit Current	2.75mA
Max no. of PAD100-IM on SLC loop	254 Units
Operating Temperature Range	32 to 120°F (0 to 49°C)
Operating Humidity Range	0 to 93% (non-condensing)
Dimensions	4.17" (106mm)L × 4.17" (106mm)W × 1.14" (29mm)D
Mounting Options	Standard 4" Square or Double Gang Box
Shipping Weight	0.6 lbs

Installation Using Compatible Electrical Box

Fig 1

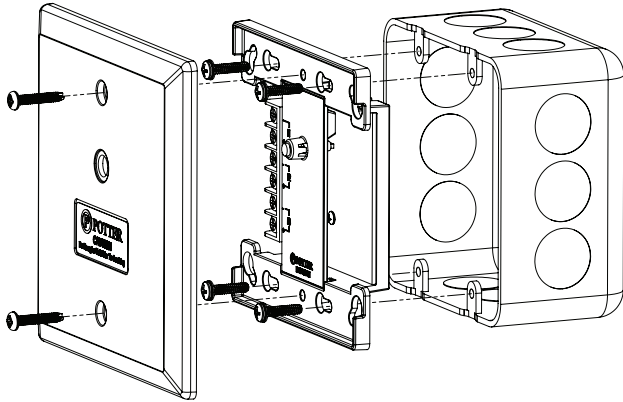

Wiring Diagrams

PAD100-IM Class X Example

Fig 2

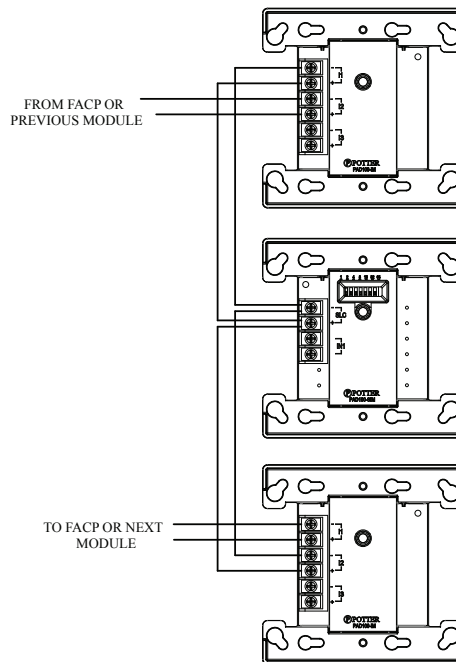

Ordering Information

Model	Description	Stock No.
PAD100-IM	Isolator Module	3992708