

1 Entry Door & Transom - Section Detail  
SCALE: 1 1/2" = 1'-0"

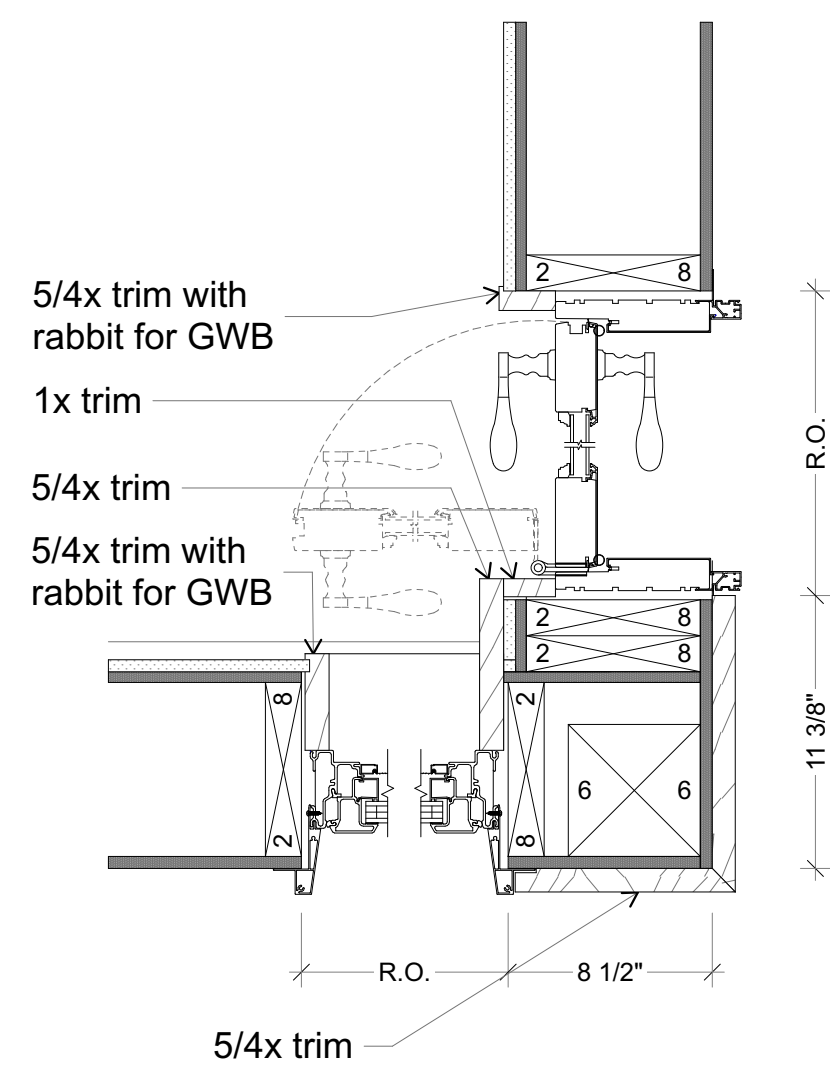

2 Entry Door & Window - Plan Detail  
SCALE: 1 1/2" = 1'-0"

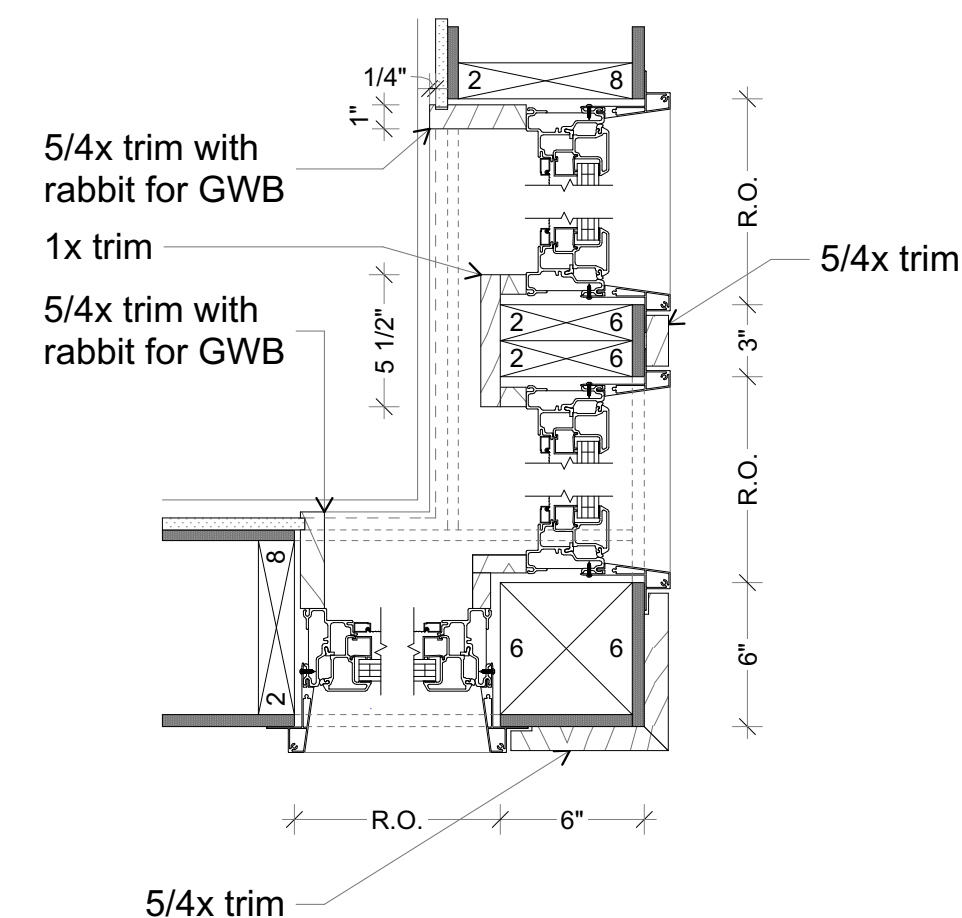

3 Corner Window - Plan Detail  
SCALE: 1 1/2" = 1'-0"

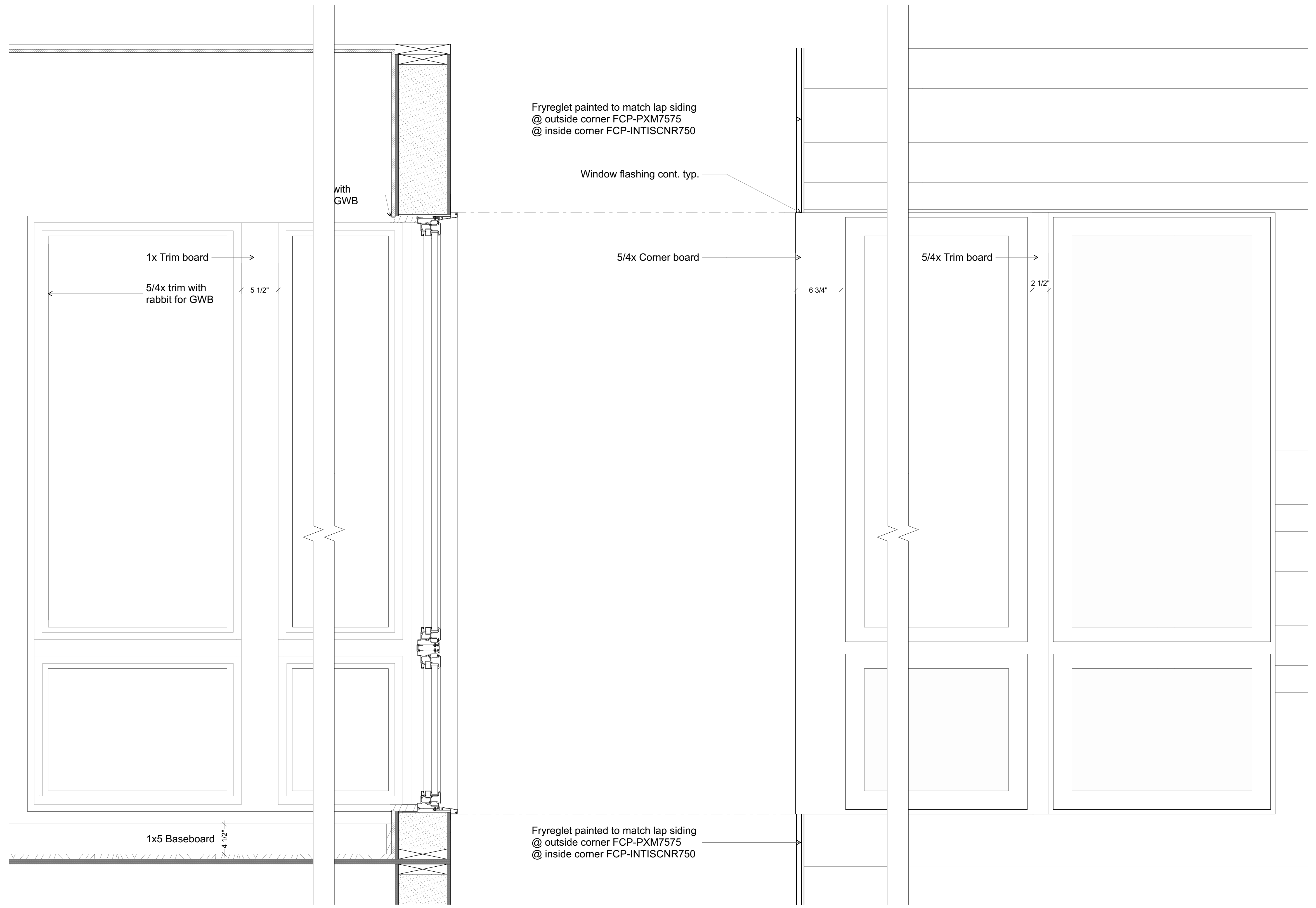

4 Interior & Exterior Trim Typical  
SCALE: 1 1/2" = 1'-0"