

**LAFAYETTE THREE-FAMILY  
LEGALIZING NON-CONFORMING UNIT**  
47 LAFAYETTE STREET  
JOSHUA WOJCIK

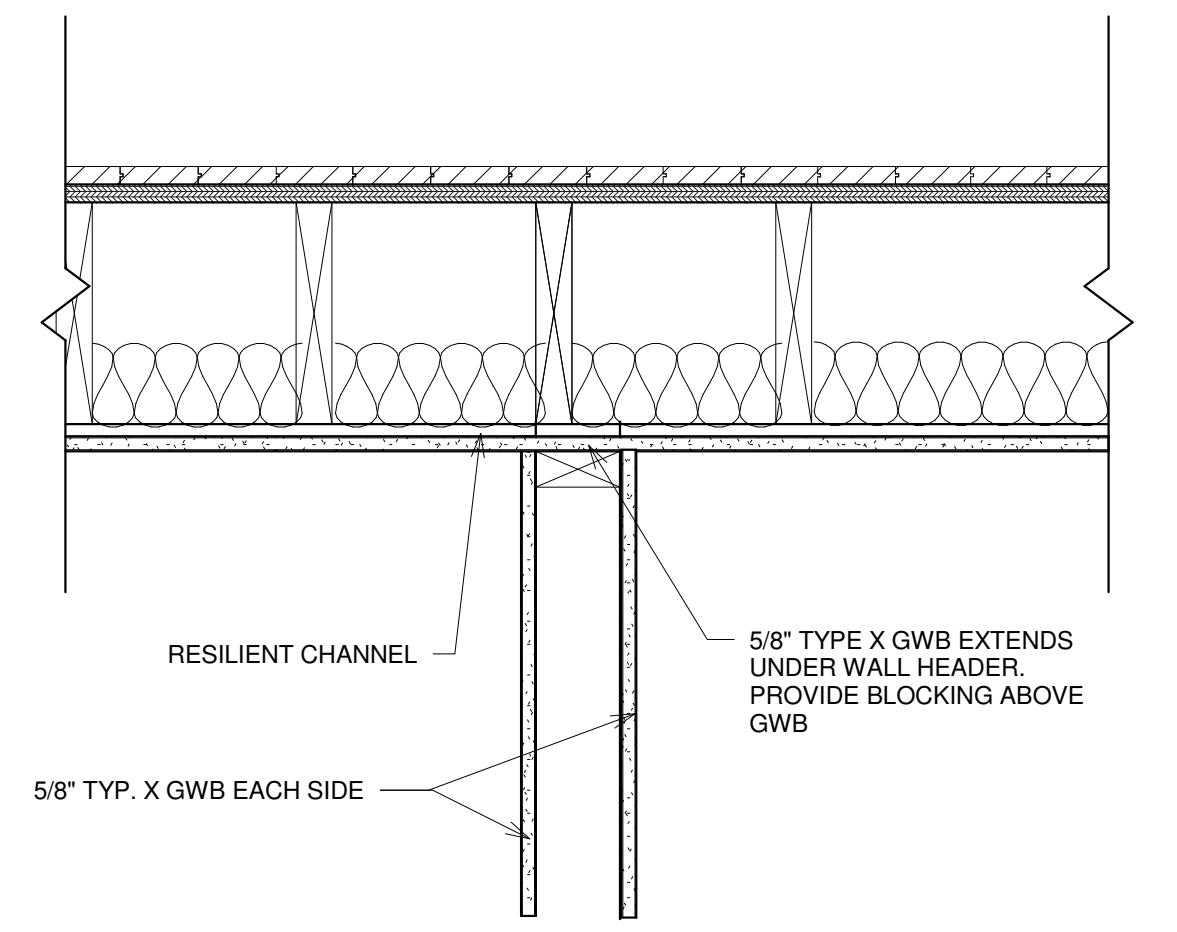

**DEXTROUS  
CREATIVE**  
PORTLAND, ME 04102  
TRACIE REED, ARCHITECT  
NCARB, AIA, LEED AP BD+C  
traciereed@dextrouscreative.com  
207.409.0459 (cell)



**C TYPICAL HEAD DETAIL**  
1 1/2" = 1'-0"

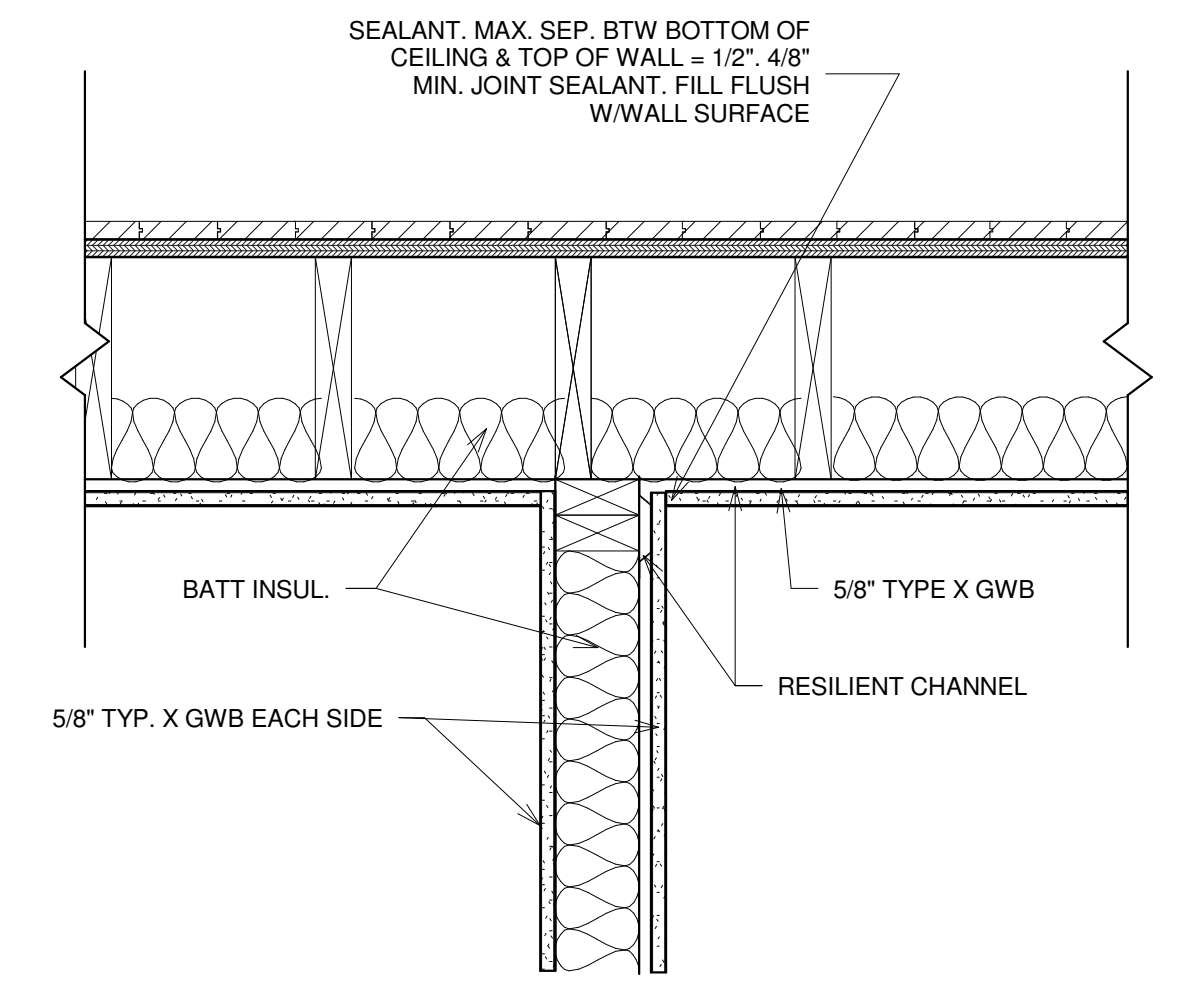

**D TYPICAL HEAD OF WALL DETAIL @  
RATED WALL**  
1 1/2" = 1'-0"

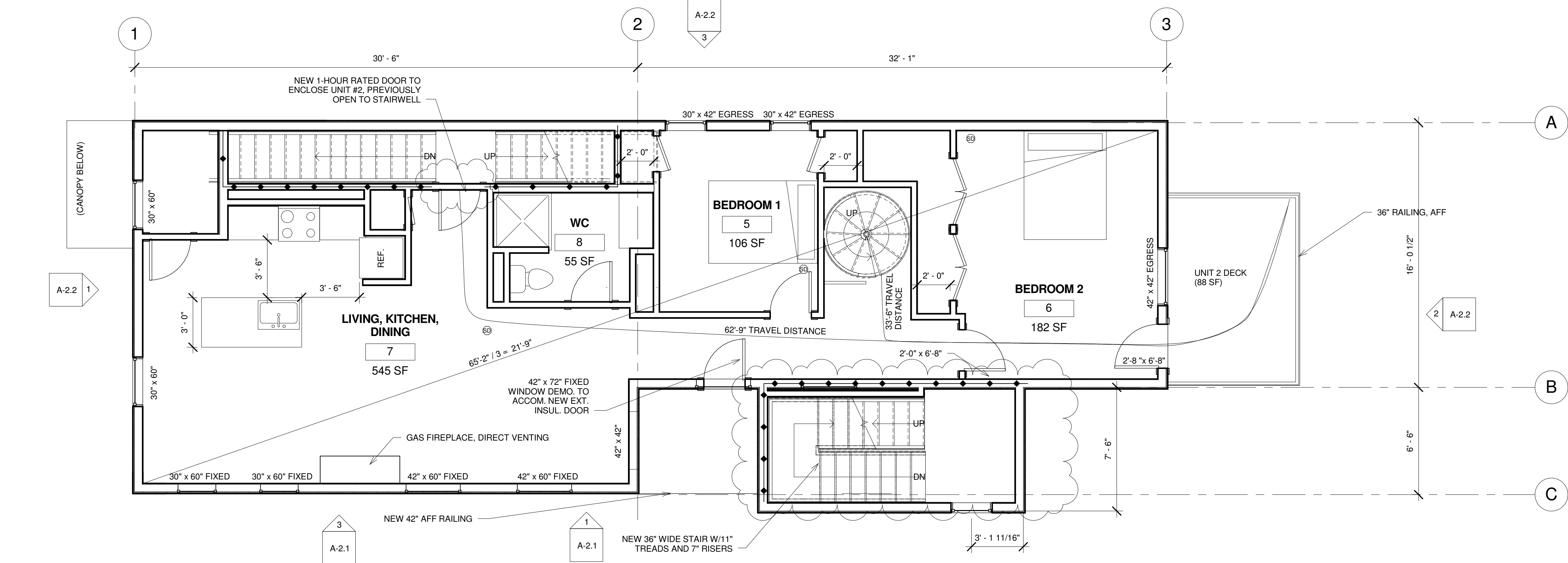

**A Second Floor**  
1/4" = 1'-0"  
SCOPE OF WORK: ADDITION OF 1-HOUR RATED DOOR AT LANDING TO CREATE UNIT ON SECOND FLOOR

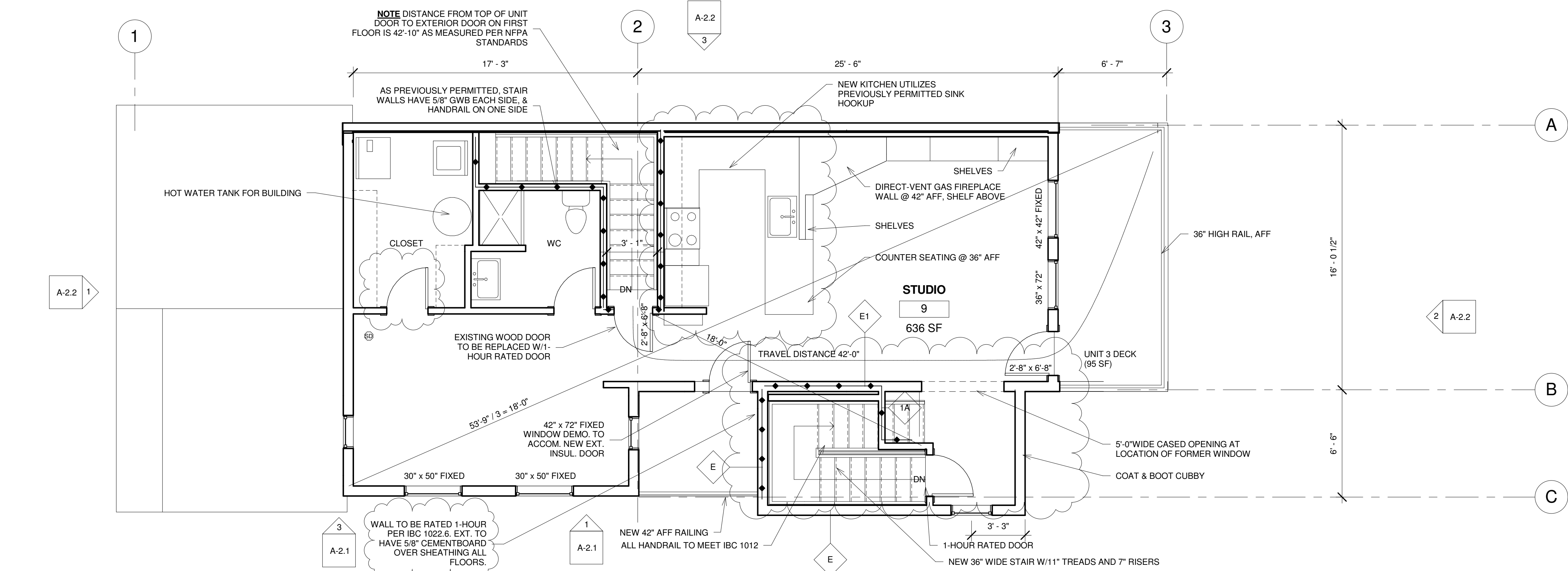

**B Third Floor**  
1/4" = 1'-0"  
SCOPE OF WORK: CHANGE EXISTING UNRATED DOOR AT TOP OF STAIRS TO 1-HOUR RATED DOOR AND ADD KITCHEN CABINETS/BUILT-INS. KITCHEN SINK TO UTILIZE PREVIOUSLY PERMITTED BAR SINK HOOKUP. ALL OTHER WORK WAS PREVIOUSLY PERMITTED.

**TYPE 1A | UL 305**  
**1-HOUR RATING**

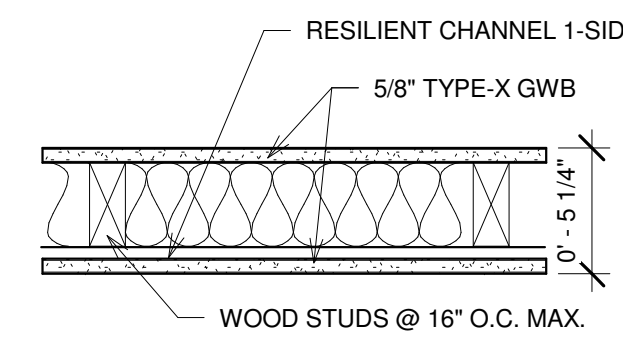

**DESCRIPTION - STC 50 PER CERTAINTED TEST, WHI ST-2**  
-5/8" TYPE-X GWB, W/BEVELED, SQUARE OR TAPERED EDGES, APPLIED VERTICALLY OR HORIZONTALLY  
-2x4 WOOD STUDS SPACED MAX. 16" O.C. FILL W/3 1/2" FIBER GLASS INSULATION  
-INTERIOR SURFACE RESILIENT CHANNEL  
-5/8" TYPE-X GWB, W/BEVELED, SQUARE OR TAPERED EDGES, APPLIED VERTICALLY OR HORIZONTALLY

**E1 | EXISTING  
EXTERIOR WALL**  
**R-21+**

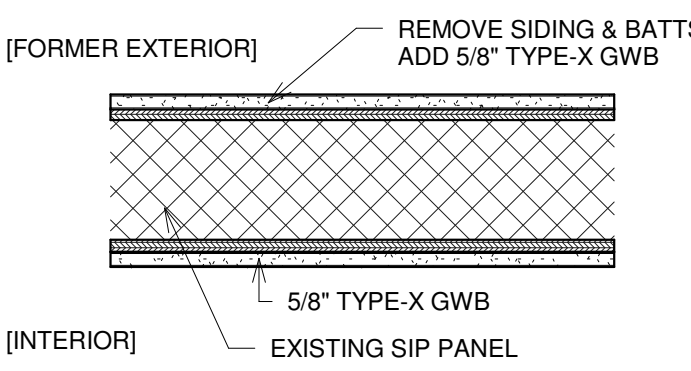

**DESCRIPTION (INTERIOR TO EXTERIOR)**  
-5/8" TYPE-X GWB, W/BEVELED, SQUARE OR TAPERED EDGES, APPLIED VERTICALLY OR HORIZONTALLY  
-SIP PANEL (UPPER TWO FLOORS)  
-5/8" TYPE-X GWB, W/BEVELED, SQUARE OR TAPERED EDGES, APPLIED VERTICALLY OR HORIZONTALLY

**E | NEW EXTERIOR  
WALL**  
**R-21**

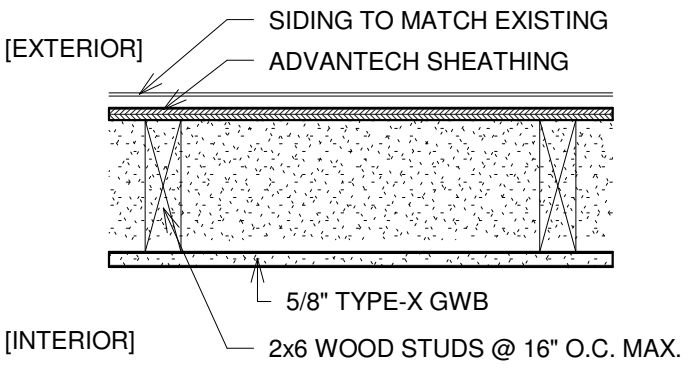

**DESCRIPTION (INTERIOR TO EXTERIOR)**  
-5/8" TYPE-X GWB, W/BEVELED, SQUARE OR TAPERED EDGES, APPLIED VERTICALLY OR HORIZONTALLY  
-2x6 WOOD STUDS SPACED  
-GREEN FIBER 765 FILLED TO 3.5# PER CUBIC FOOT PER STANDARD INSTALL. INSTRUCT.  
-ADVANTECH SHEATHING, TAPE EDGES AND PENETRATIONS, TYP.  
-1x4 WOOD STRAPPING AS RAIN SCREEN RUN VERT.  
-SIDING TO MATCH EXISTING.

**E WALL DETAILS**  
1 1/2" = 1'-0"

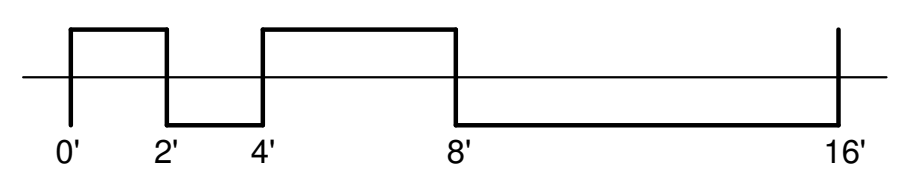

No.	Description	Date
1	Revision 1	Date 1

**SECOND &  
THIRD FLOOR  
PLAN**

Project number 16-22  
Date 03.07.17  
Drawn by TJR  
Checked by TJR

**A-1.2**

Scale As indicated