

**LAFAYETTE THREE-FAMILY
LEGALIZING NON-CONFORMING UNIT**
47 LAFAYETTE STREET
JOSHUA WOJCIK

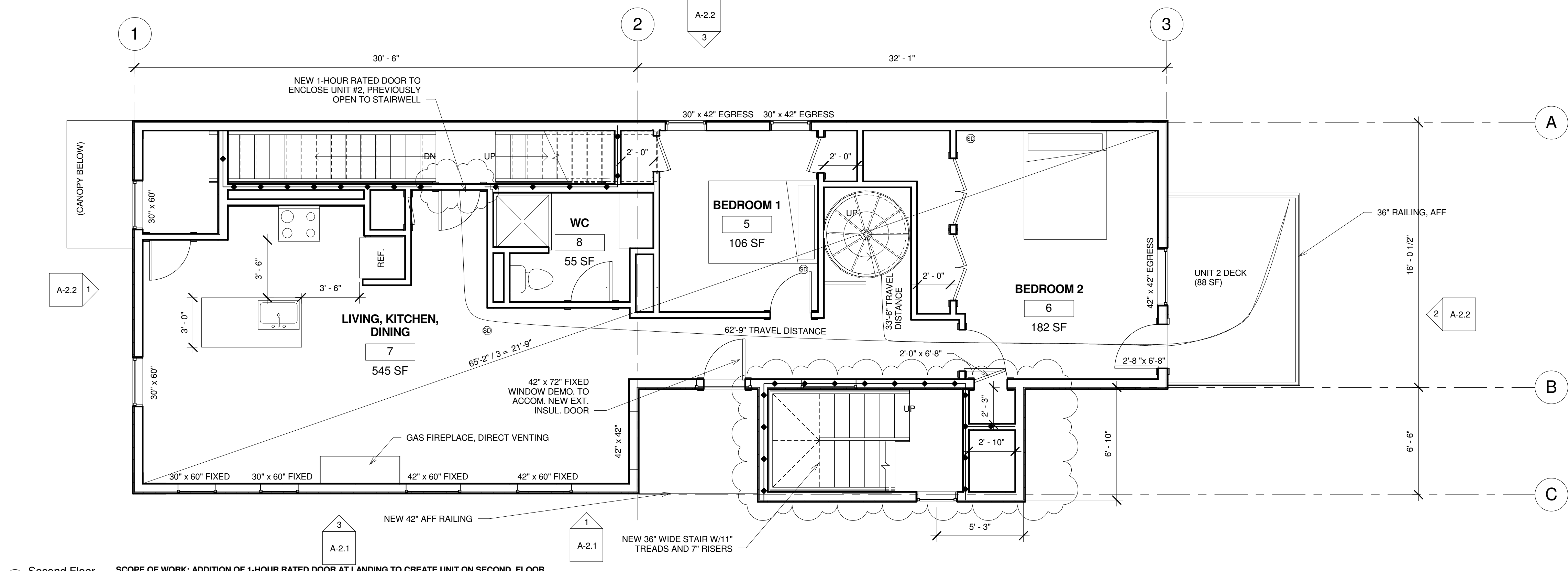

**DEXTROUS
CREATIVE**
PORTLAND, ME 04102
TRACIE REED, ARCHITECT
NCARB, AIA, LEED AP BD+C
traciereed@dextrouscreative.com
207.409.0459 (cell)



A Second Floor
1/4" = 1'-0"
SCOPE OF WORK: ADDITION OF 1-HOUR RATED DOOR AT LANDING TO CREATE UNIT ON SECOND FLOOR

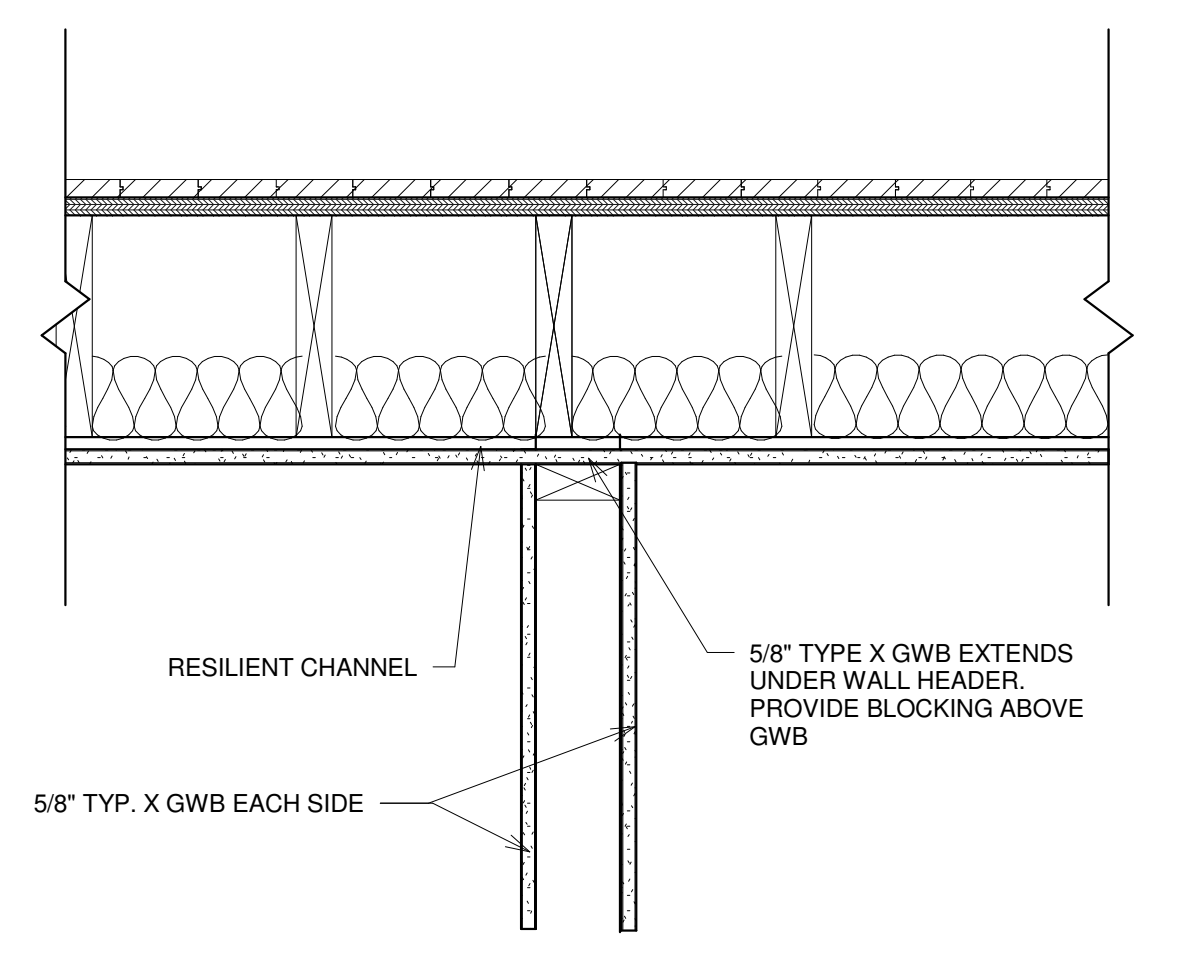

C TYPICAL HEAD DETAIL
1 1/2" = 1'-0"

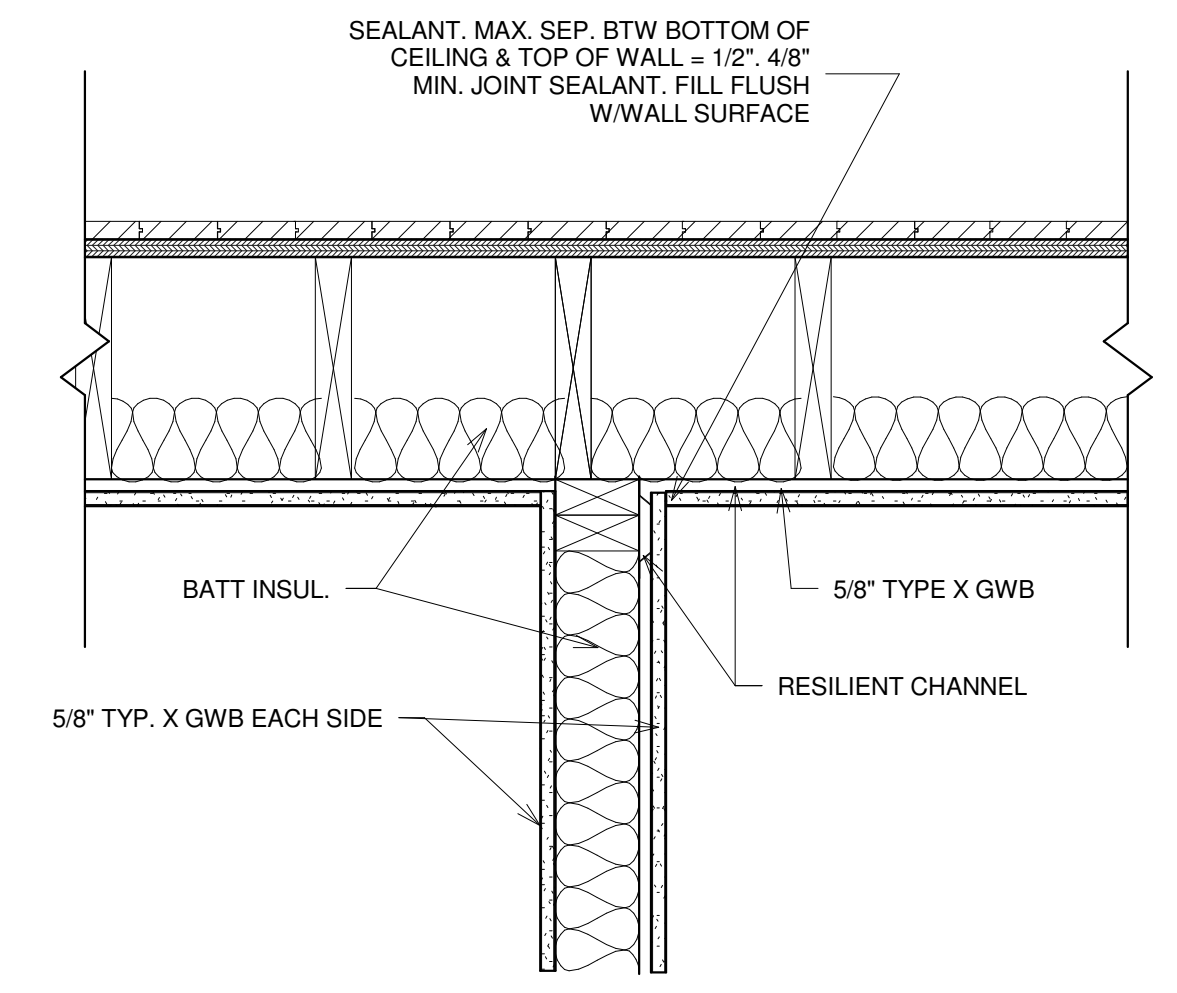

D TYPICAL HEAD OF WALL DETAIL @
RATED WALL
1 1/2" = 1'-0"

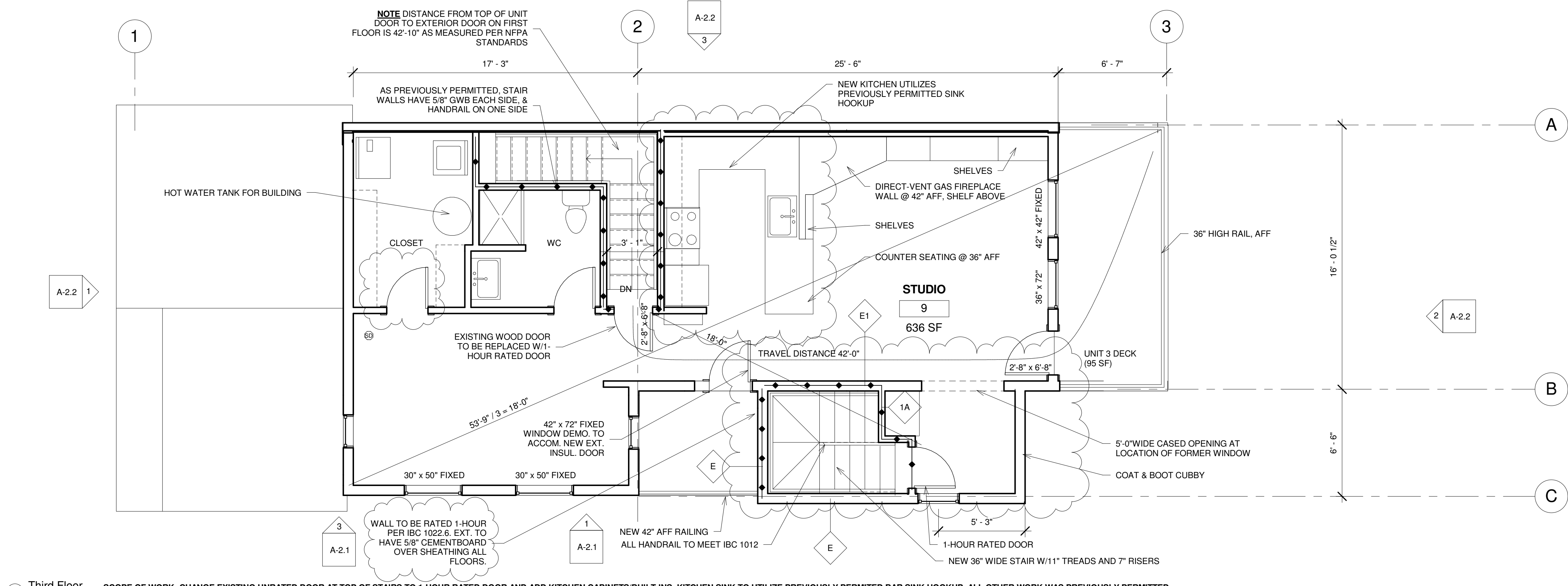

B Third Floor
1/4" = 1'-0"
SCOPE OF WORK: CHANGE EXISTING UNRATED DOOR AT TOP OF STAIRS TO 1-HOUR RATED DOOR AND ADD KITCHEN CABINETS/BUILT-INS. KITCHEN SINK TO UTILIZE PREVIOUSLY PERMITTED BAR SINK HOOKUP. ALL OTHER WORK WAS PREVIOUSLY PERMITTED.

**TYPE 1A | UL 305
1-HOUR RATING**

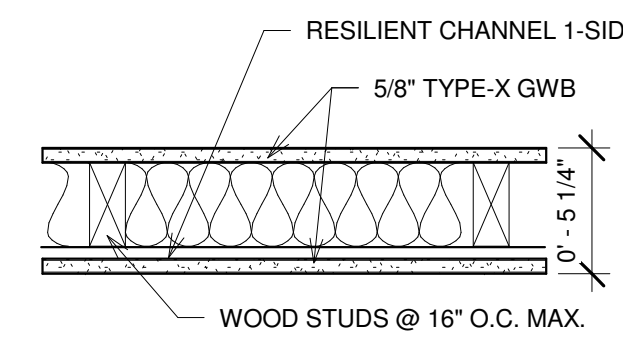

DESCRIPTION - STC 50 PER CERTAINTED TEST, WHI ST-2
-5/8" TYPE-X GWB, W/BEVELED, SQUARE OR TAPERED EDGES, APPLIED VERTICALLY OR HORIZONTALLY
-2x4 WOOD STUDS SPACED MAX. 16" O.C. FILL W/3 1/2" FIBER GLASS INSULATION
-INTERIOR SURFACE RESILIENT CHANNEL
-5/8" TYPE-X GWB, W/BEVELED, SQUARE OR TAPERED EDGES, APPLIED VERTICALLY OR HORIZONTALLY

**E1 | EXISTING
EXTERIOR WALL
R-21+**

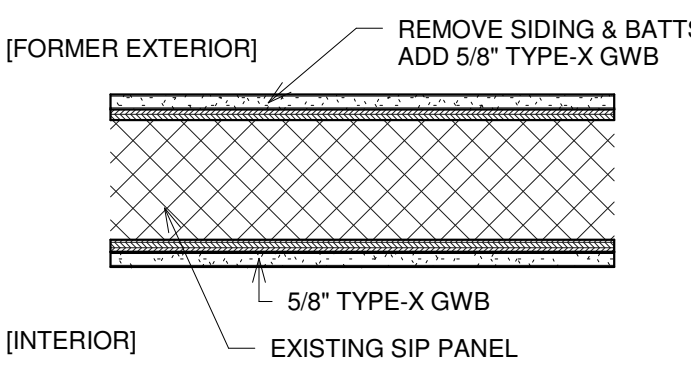

DESCRIPTION (INTERIOR TO EXTERIOR)
-5/8" TYPE-X GWB, W/BEVELED, SQUARE OR TAPERED EDGES, APPLIED VERTICALLY OR HORIZONTALLY
-SIP PANEL (UPPER TWO FLOORS)
-5/8" TYPE-X GWB, W/BEVELED, SQUARE OR TAPERED EDGES, APPLIED VERTICALLY OR HORIZONTALLY

**E | NEW EXTERIOR
WALL
R-21**

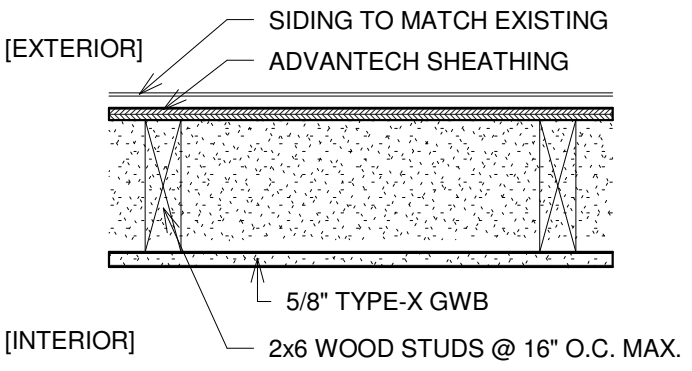

DESCRIPTION (INTERIOR TO EXTERIOR)
-5/8" TYPE-X GWB, W/BEVELED, SQUARE OR TAPERED EDGES, APPLIED VERTICALLY OR HORIZONTALLY
-2x6 WOOD STUDS SPACED
-GREEN FIBER 765 FILLED TO 3.5# PER CUBIC FOOT PER STANDARD INSTALL. INSTRUCT.
-ADVANTECH SHEATHING, TAPE EDGES AND PENETRATIONS, TYP.
-1x4 WOOD STRAPPING AS RAIN SCREEN RUN VERT.
-SIDING TO MATCH EXISTING.

E WALL DETAILS
1 1/2" = 1'-0"

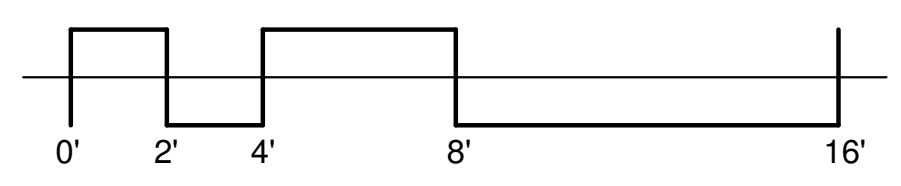

No.	Description	Date
1	Revision 1	Date 1

**SECOND &
THIRD FLOOR
PLAN**

Project number	16-22
Date	03.07.17
Drawn by	TJR
Checked by	TJR

A-1.2

Scale As indicated