

United Window & Door - Series 700 New Construction Casement Windows Specifications

Part 1 GENERAL

1.01 INCLUSIONS

1. All windows as called for in this specification will be furnished with all necessary hardware and parts as herein specified and shall be manufactured by United Window and Door Manufacturing, Inc.

1.02 RELATED SECTIONS

As required

1.02 QUALITY ASSURANCE

A. General.

1. Provide independent third party notice of product certification showing products to be in full compliance with AAMA/WDMA/CSA 101/I.S.2/A440-05 and ANSI/AAMA/WDMA 101/I.S.2/NAFS-02.and the following:
 - a. Vinyl Casement window to be United Series 700 C-R50 24" x 60".
 - b. Vinyl Twin Casement window to be United Series 700 C-R50 40" x 60".

B. Test Units.

1. Perform all tests listed in accordance with AAMA/WDMA/CSA 101/ I.S.2/A440-05 and others.

C. Test Procedures.

1. Air Infiltration Test- With the window in the closed and locked position test in accordance to ASTM E283 at a static pressure of 1.56 psf (25 mph). Air infiltration shall not exceed maximum of .08 cfm per square foot of frame area.
2. Water Resistance Test- With the window in the closed and locked position test in accordance with ASTM E 547 at the static pressure of 9 psf. There shall be no uncontrolled water leakage as defined in ASTM E 547.
3. Uniform Load Test- with the window in a closed and locked position test in accordance to ASTM E330. When tested in positive and negative loads there shall be no glass breakage, permanent damage to fasteners, hardware, or any other parts that would render the window inoperable.

1.04 REFERENCES

A. American Society of Testing Materials (ASTM):

1. ASTM C 509-94 Specification for Elastomeric Cellular Preformed Gasket and Sealing Material.
2. ASTM B 633-85 Specification for Electrodeposited Coatings of Zinc on Iron or Steel.
3. ASTM B 766-86 Specifications for Electrodeposited Coatings on Cadmium.
4. ASTM C 1036-91 Specifications for Flat Glass.
5. ASTM E 774-92 Specification for Sealed Insulated Glass Units.

B. American Architectural Manufacturers Association (AAMA):

1. AAMA 701-92 Voluntary Specification for Pile Weather-Stripping.
2. AAMA 800-92 Voluntary Specification and Test methods for Sealants.
3. AAMA 902-94 Voluntary Specifications for Sash Balances.
4. AAMA 901.1-90 Voluntary Specification for Rotary Operators in Window Applications.

1.05 SUBMITTALS

A. Shop Drawings: Submit shop drawings as required.

B. Product Data: submit product data as required.

C. Product Samples: submit product samples as required.

1. Submit full window include glazing system, quality of construction and specified finish.

D. Quality Control:

1. Certification: submit performance test results reported by independent laboratory or manufacturer's statement of qualification indicating compliance with specified performance and design requirements.

1.06 DELIVERY, STORAGE AND HANDLING

A. Comply with provisions of job specification.

B. Store units upright in a clean, well ventilated area free of dust and corrosive fumes. Windows must not be stored above 120 degrees F.

C. Windows may not be stored in direct sunlight or covered with plastic sheet.

D. Protect finish surfaces from lime, mortar run-off, weld splatter, acids, roofing tar, solvents or other items that could cause damage to the finish.

1.07 WARRANTY

- A. The installer shall assume full responsibility that the installation is in accordance with the specifications, contract document and United Window & Door specifications.
- B. Manufacturer's Warranty: furnish United Window & Door Lifetime Limited Warranty.

Part 2 PRODUCTS

2.01 MATERIALS

- A. The vinyl extrusions will be AAMA certified.
- B. All vinyl extrusions will be free of defects impairing strength or durability.

2.02 COMPONENTS

- A. Mainframe and sash:
 - 1. Mainframe will have a nominal exterior wall thickness of .065".
 - 2. Sashes will have a nominal exterior wall thickness of .075".
- B. Weather Stripping:
 - 1. Weather stripping and compression seals must be of high quality, proven to be capable of meeting or exceeding the environmental exposure and performance requirements of the application.
 - 2. Woolpile and finseal weather stripping shall conform to AAMA 702-92.
 - 3. Closed cell elastomeric compression seals shall conform to ASTM C 509.
- C. Fasteners:
 - 1. All screws and other fastening devices incorporated shall be of aluminum, stainless steel, or other non corrosive material compatible with the vinyl extrusions. Cadmium or zinc plated steel shall be in accordance with ASTM B 766-86 or ASTM B 633-85. Nickel or chrome plated shall be in accordance with ASTM B 456-94 type SC.
- D. Insect Screens:
 - 1. Insect screen frames will be of aluminum extruded box shape, for strength and durability, and be manufactured in accordance to United Window and Door approved design. Insect screen frames will be color matched to the window color. The screens will incorporate fiberglass screen cloth of 18 x 16 mesh held in the frame by vinyl screen spline.
- E. Glass and glazing materials
 - 1. Insulated glass:

- a. The assembled insulated glass unit shall be ¾" thickness high performance. The assembly will conform to ASTM E 774-92, level A.
- b. Tempered glass will conform to ASTM C 1048-91.
- c. Annealed glass will conform to ASTM C 1036-91.

2. Glazing Materials:

- a. The insulated glass unit will be secured to the vinyl sash or frame by a silicone ductile bedding compound.

F. Hardware

- 1. Hardware having component parts which are exposed will be aluminum, stainless steel or other non-corrosive material compatible with the vinyl extrusions. Cadmium or zinc plated steel shall be in accordance with ASTM B 766-86 or ASTM B 633-85. Nickel or chrome plated shall be in accordance with ASTM B 456-94 type SC.

G. Sash Operators

- 1. Rotary sash operators shall meet AAMA 901.1-90.

H. Window Locks

- 1. Sashes shall be capable of being locked at multiple points while operating a single locking lever.
- 2. When in locked position shall conform to ASTM F 588-85 Resistance of Window Assemblies to Forced Entry Excluding Glazing.

Part 3 EXECUTION

3.01 EXAMINATION

- A. Verification of conditions
 - 1. Before installation verify all openings are plumb, square and of proper dimensions. Report frame defects or unsuitable conditions to the General contractor before proceeding.
- B. Acceptance
 - 1. Beginning of installation means acceptance of existing conditions.

3.02 INSTALLATION

- A. The window will be secured to the rough opening in accordance with manufacturer's instructions and/or accepted industry practice.
 - 1. All windows will be installed level and plumb.
 - 2. A permanent weather tight seal must be applied between the window nailing flange and the building exterior wall at the time of installation.
 - 3. The windows are to be secured to the opening with 1 ½" or longer fasteners through every other pre-punched hole in the nailing flange.

-
-
- B. Install sealant and related backing materials at perimeter of assembly in accordance to Section 07900 Joint Sealers. Do not use foam sealant.

3.03 ADJUSTING AND CLEANING

- A. Adjust operable sash to work freely with all hardware functioning properly. Readjust at completion of project if directed to do so.
- B. Remove all visible labels except permanent identification, warning, or instructional labels.
- C. Leave windows in a wiped clean condition.

3.04 PROTECTION

- A. Cover windows during spray painting or other construction operations that might cause damage.
- B. Remove screens and store them in a safe area during construction.

Series 700 New Construction Casement Installation Detail

2x4 or 2x6 Frame Construction with Brick Exterior
Vertical Section *

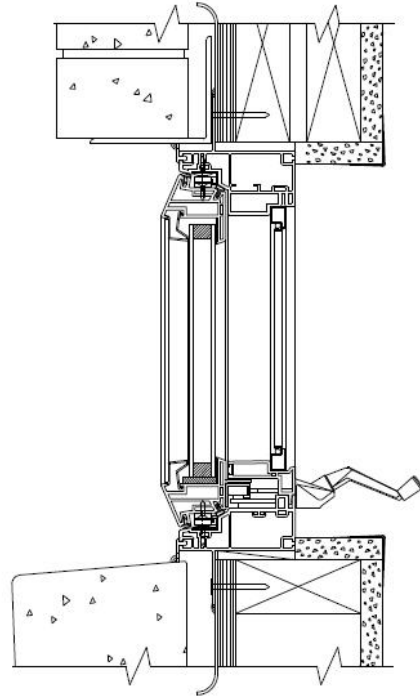

Horizontal Section *

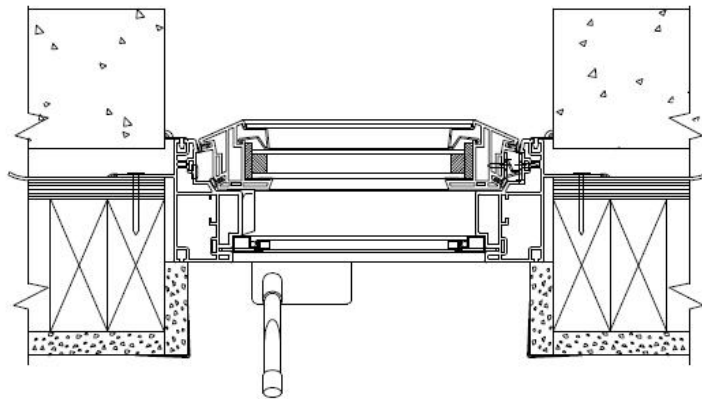

*Drawings are for reference only. See complete instructions before installing.

Series 700 New Construction Casement Installation Detail

2x4 or 2x6 Frame Construction with Siding Exterior
Vertical Section *

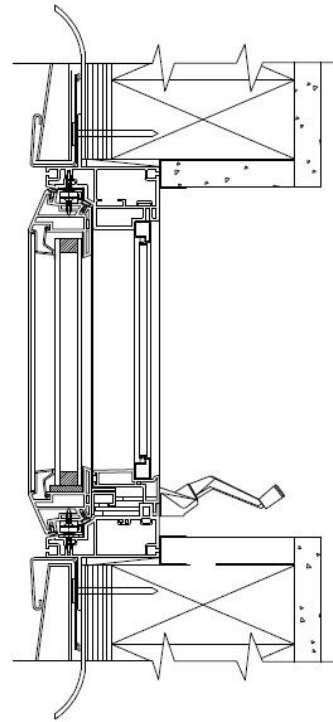

Horizontal Section *

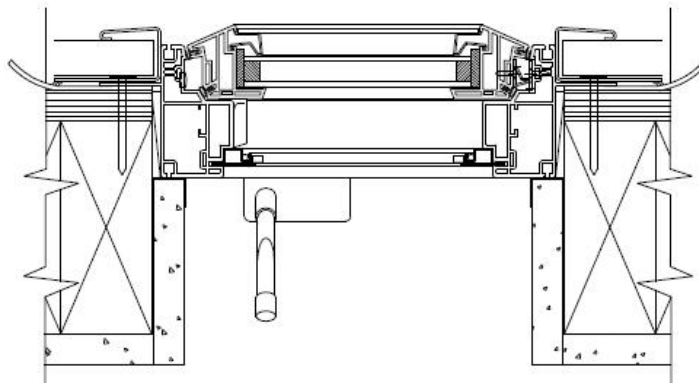

*Drawings are for reference only. See complete instructions before installing.

Series 700 New Construction Casement Installation Detail

2x4 or 2x6 Frame Construction with Stucco Exterior
Vertical Section *

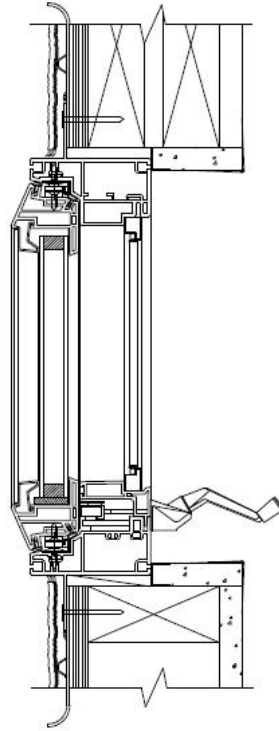

Horizontal Section *

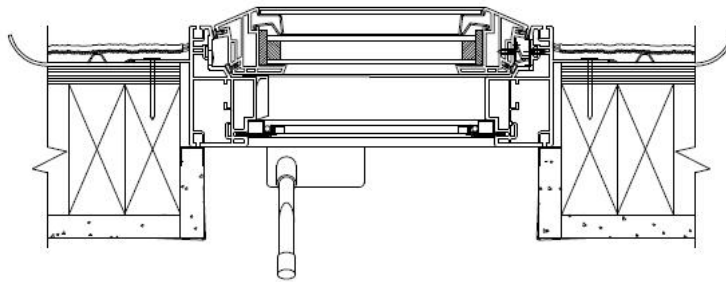

*Drawings are for reference only. See complete instructions before installing.